

(Original instructions)



operating instructions

mini-excavator 9VXE

serial numbers from n°:
EA09*0010

© € 06/12 - R00
cod. 2032807005

/// IHIMER

a joint venture
IHI
GROUP 

ihimer.com

CONTENTS

FOREWORD	0-1
INTRODUCTION	0-1
MACHINE NUMBER	0-2
MACHINE DIRECTION	0-3
SAFETY	1-1
SAFETY INFORMATION	1-1
SAFETY PRECAUTIONS	1-2
SAFETY SIGNS AND LABELS	1-13
OPERATION	2-1
NAMES OF COMPONENTS	2-1
CONTROLS AND INSTRUMENTS	2-2
STARTING ENGINE	2-9
STOPPING ENGINE	2-13
RUNNING IN NEW MACHINE	2-14
LEVER OPERATIONS	2-15
CRAWLER EXTENSION/RETRACTION OPERATION	2-18
BLADE OPERATION	2-19
BOOM SWING OPERATION	2-19
SWING OPERATION	2-20
TRAVELING	2-21
WORK INSTRUCTIONS	2-24
PRECAUTIONS FOR WORKS	2-25
PRECAUTION ON USE OF RUBBER SHOE	2-28
PTO (POWER TAKE-OFF) FOR SPECIAL ATTACHMENT USE	2-31
TOWING	2-34
TRANSPORT	2-35
LIFTING THE MACHINE	2-37
MAINTENANCE	3-1
PERIODIC REPLACEMENT OF THE IMPORTANT PARTS	3-1
MAINTENANCE INTERVALS	3-2
RECOMMENDED LUBRICATION TABLE	3-5
LUBRICATE THE GREASE	3-6
MAINTENANCE OF BUCKET	3-9
CRAWLER SHOE	3-10
TRAVEL REDUCTION GEAR	3-13

HYDRAULIC SYSTEM DIAGRAM	3-18
ENGINE OIL	3-19
FUEL SYSTEM	3-21
COOLING SYSTEM	3-24
INTAKE AIR SYSTEM	3-28
ENGINE	3-29
ELECTRIC SYSTEM	3-30
ELECTRIC SYSTEM DIAGRAM	3-32
TIGHTEN BOLTS	3-35
HANDLING IN COLD WEATHER	3-37
LONG TERM STORAGE	3-38
SPECIFICATIONS	4-1
SPEED AND GRADEABILITY	4-1
ENGINE	4-1
MASS	4-1
CAPACITY	4-1
BUCKET	4-2
DIMENSIONS	4-3
WORKING RANGE	4-4
WORKING RANGE FOR OFFSET DIGGING	4-5

FOREWORD

INTRODUCTION

This manual contains the safety, operation, maintenance and adjustment procedures of this machine.

Read it and have good understanding before using the machine.

Contact our dealer immediately if you lose or damage this manual.

See the "Operation Manual of the Engine" for the engine.

If you hand over this machine to any third party, this manual should also be handed over to it.

The specifications of the machine may be improved and differ from descriptions of this manual. Please contact our dealer if you have some problems or questions.

FOREWORD

MACHINE NUMBER

The machine No. and engine No. are marked at the positions shown below.

MODELL	9VXE
SERIAL No.	

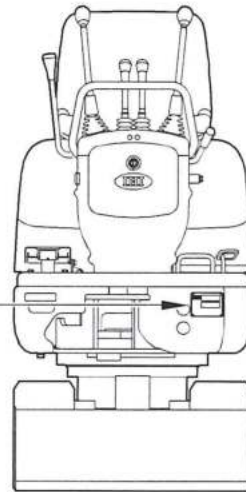

WB-C010010

MODELL	2TNV70-PIKX
ENGINE SERIAL No.	

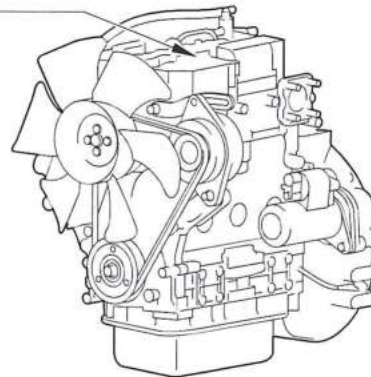

WB-C010020

FOREWORD

MACHINE DIRECTION

The front, rear, right and left directions of the machine are determined based on the orientation when the driver is seated on the operator seat with the blade frontward, as shown below.

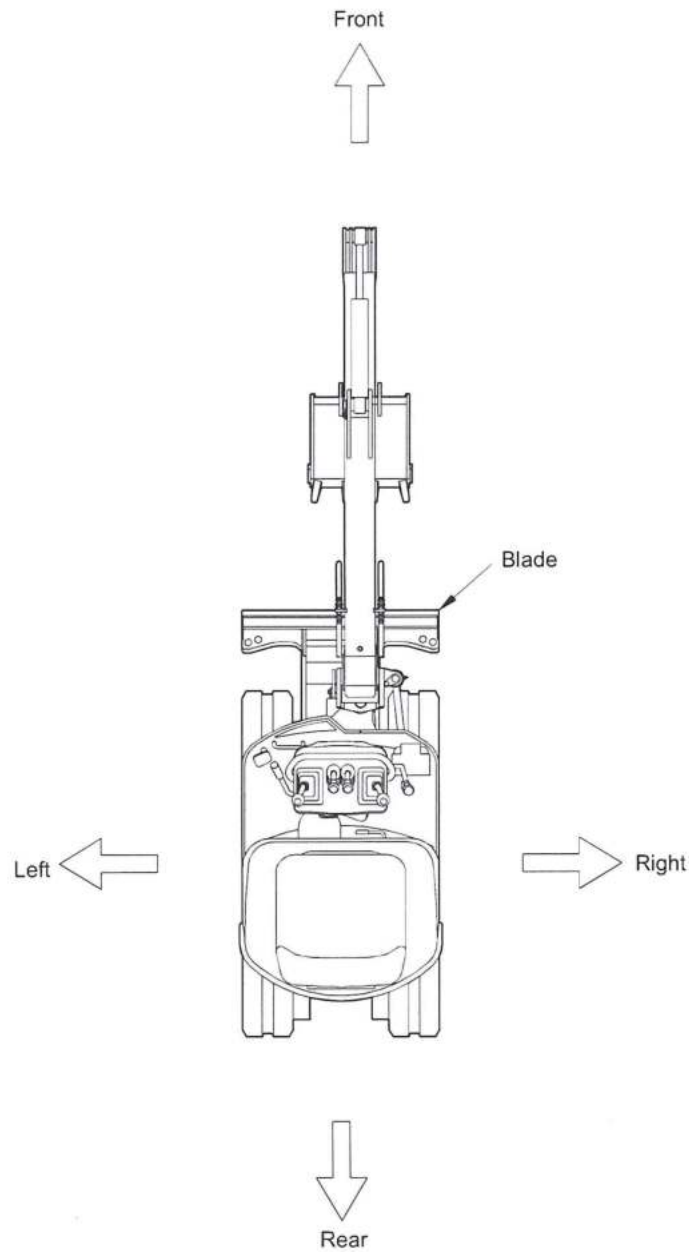

WB-C010030

FOREWORD

This page is intentionally left blank

SAFETY

Most accidents occur during works when preventive measures against danger are neglected or basic safety instructions are not observed.

Such accidents may be avoided by paying careful attention in advance.

This manual describes the basic safety instructions to be observed in daily operation, inspection and maintenance of the machine.

Observe these instructions carefully for safety.

Check the safety with great care for any other matters not described in this manual.

SAFETY

SAFETY INFORMATION

Read and understand the operation manual, safety signs and labels before using or maintaining this machine.

The safety alert symbol is used to alert you to potential personal injury hazards. Obey all safety messages that follow this symbol to avoid possible injury or death.

The signal words used with the safety alert symbol indicate a specific level of severity of the potential hazard. All are used as attention-getting devices throughout this manual as well as on labels fixed to the machine to assist in potential hazard recognition and prevention.



This safety alert symbol and signal word indicates an imminently hazardous situation which, if not avoided, will result in death or serious injury.



This safety alert symbol and signal word indicates a potentially hazardous situation which, if not avoided, could result in death or serious injury.

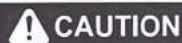

This safety alert symbol and signal word indicates a potentially hazardous situation which, if not avoided, could result in minor or moderate injury or serious damages of the machine.

NOTICE

This signal word indicates a potentially hazardous situation which, if not avoided, could result in damages of the machine or reduction of the service life.

We have made every effort for you to prevent accidents during operation; however, we cannot be held responsible for predicting every kind of danger in all operating conditions.

It is the owner or user of the machine who is responsible for always paying attention to operate the machine, as well as reading and understanding this manual enough to obtain the essential knowledge and skills fundamental to correct machine operation.

SAFETY

SAFETY PRECAUTIONS

PRECAUTIONS BEFORE OPERATION

Read and understand the safety signs and labels

- There are several specific safety signs on your machine.
Please read and understand the safety signs and labels.
- You must replace a label if it is damaged, missing or cannot be read.

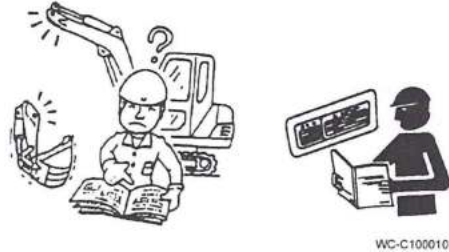

WC-C100010

Make a work plan

Start the work only after discussing with the person in charge at the site.

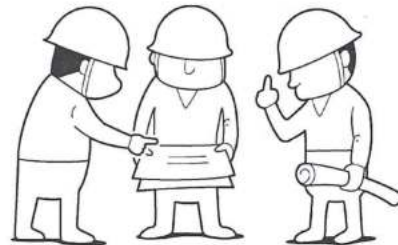

CQ0-01880

Wear proper working clothes

For the sake of safety during working, wear clothes that match your body.

Always wear required protective items such as protective cap, protective goggles, reflective clothing, safety shoes, and ear protection as required.

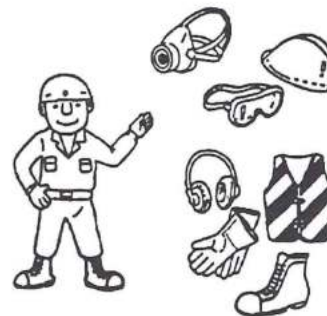

CA-C100030

Watch for underground utilities

Mark the location of underground utilities such as gas lines, sewers, and power lines before any digging operations. If necessary, the utilities should be temporarily discontinued.

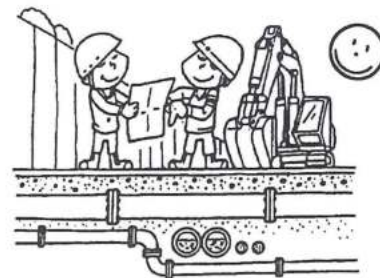

WC-C100620

SAFETY

Perform "walk-around" inspection

Be sure to walk around the machine and inspect it before starting work. If some defects are found, repair them without fail.

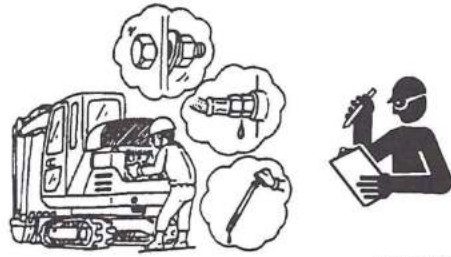

WC-C100030

Prevent a fire

- Do not leave oiled waste cloth, dead leaves, paper trash or other flammable objects around the engine. Such matters may cause a fire. Always inspect and remove such matters.
- Stop the engine and do not bring fire close to it while refilling fuel.
- Check if fuel, oil or hydraulic oil does not leak. If some defects are found, repair them and wipe off leaked oil.
- Check the installation position and usage of the fire extinguisher.



CA-C100380

Install the ROPS canopy

We recommend that the ROPS canopy should be installed to avoid accidents, which may result in injury, if a machine with a canopy should fall down.



WC-C100060

Carefully mount and dismount the machine

Always use steps and handholds to mount and dismount the machine.

Hold the handholds with both hands and face the machine keeping a contact with at least three points of the steps and handrails.

Never hold control levers at mounting and dismounting.



WC-C100070

Start the engine in the operator's seat

If the engine is started from a position other than sitting in the operator's seat, there is the danger that the machine starts moving suddenly.

Start the engine only after carrying out checks while sitting in the operator's seat.



WC-C100080

SAFETY

PRECAUTIONS DURING OPERATION

Stay seated while operating

Never attempt to operate the excavator from any position except the operator's seat. If you operate the machine from any other position, such as standing by the window or door, you may operate the machine inaccurately, which can cause serious injury. Remember that you should not get on or off the moving machine to be seated or to leave the machine.

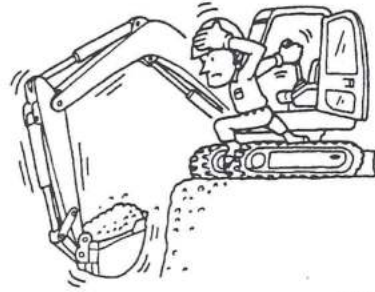

WC-C100100

Fasten the seat belt

If the machine falls down, you may be thrown out of the operator's seat or pressed under the machine. Such an accident may result in serious injury or death.

Sit on the operator's seat and fasten the seat belt all the time while operating the machine.

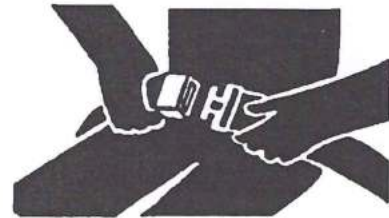

WC-C100030

Clear all personnel from the machine and area

Be sure to barricade the job site to prevent entry of the unauthorized. Confirm that there is no one around the machine before starting the engine or operating the machine.



WC-C100110

Keep Out Keep Out

Prevent accidents while moving

Always sound the horn to signal others nearby that you are moving the machine. Check that no one is within the working area of the machine before attempting to move it.



WC-C100120

SAFETY

Never swing over personnel

Be sure that no personnel are working around the machine before swinging.

Pay attention to invisible workers in a trench or pit in particular. Follow the signal person's direction not to swing over such workers.



WC-C100130

Never leave load suspended in the air

Never leave the load suspended in mid air, when the machine is out of service, or you have to leave the machine. Always put down the bucket of load onto the ground. Should a malfunction occur, it could fall, striking equipment or personnel.

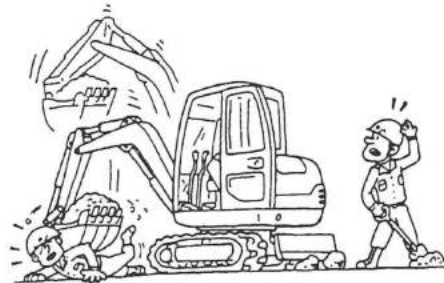

WC-C100140

Do not swing above the truck cab

If you swing the bucket above the truck cab, the driver may be injured by dropped soil and sand or the bucket contacting the truck cab.

Do not swing the bucket above the truck cab when loading soil and sand.

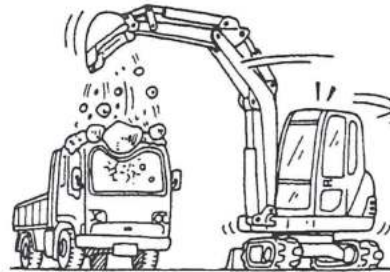

WC-C100150

Provide adequate tailswing clearance

Confirm that there is a sufficient clearance around the machine for swinging operation.

The operator tends to be unconscious of the area behind the machine. Before tailswing, make sure that there are no personnel or objects in such area.

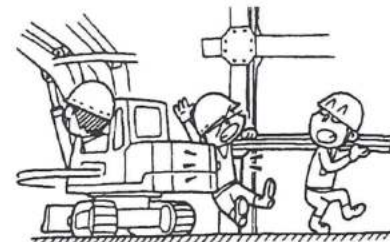

WC-C100160

Always observe the bucket and load

Always watch the moving bucket or load carefully. Moving bucket or load without care may cause injury to personnel or materials.

If you have to look away from it, stop the machine.



WC-C100170

SAFETY

Never allow unauthorized personnel to ride on the machine

Only operator is authorized to be on the machine during operation. Never let unauthorized personnel ride on the machine. Any person riding as a passenger can fall off and suffer injury.

Danger for electric power line

If the machine should contact with an electric power line, move the machine apart from the cable.

If it is impossible to move the machine, shout "Never touch the shovel" to give a warning to the workers around the machine.

Do not put on the step when you get off the shovel. Jump down onto the ground.

Maintain good ventilation

Diesel engine exhaust contains products of combustion which may be harmful to your health. Always start and operate the engine in a well ventilated area. If in an enclosed area, vent the exhaust to the outside.

Do not dig near the machine

Do not dig the ground deep near the machine to prevent falling due to collapse of the ground.

Do not dig at the base of a cliff

If you dig at the base of a cliff, it may collapse or stones may drop, causing a danger. Do not dig a cliff.

SAFETY

Never exceed the machine performance

If you use a large bucket that exceeds the machine performance, the machine may be broken or injury or death may result.

Be sure to use a bucket or attachment that meets the specifications.

Handling of loads with safety

Loads handling must be done safely by using fit accessories for anchorage and moving. Make sure and available safe accessories hook for lifting.

Before load lifting, see list of allowed loads that can be lifted at point 6-4 of this manual.

Careful! If the machinery is not flattened out, it is possible instability that can cause an overturning. In order to avoid that, utilize always short harness to prevent an excessive load of oscillation.

WARNING

- The repeated use of machine for lifting is ruled by laws in force concerning lifting equipments subject, according with national law. Hydraulic circuit of arm must be equipped by a safety device against the breaking of hydraulic pipes, available if requested.

Never lean out of the window

Do not lean out of the window, enter between the attachment and cylinder or put your hand or arm between them.

If the attachment moves, you may be caught by the attachment, resulting in serious injury or death.

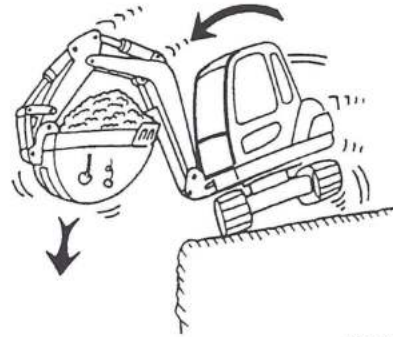

WC-C100260

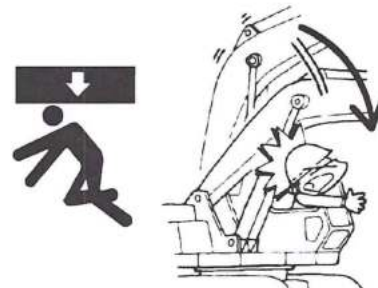
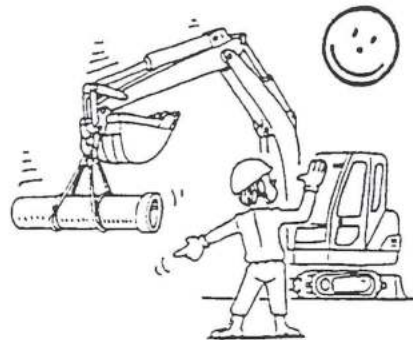

WC-C100270

SAFETY

PRECAUTIONS FOR TRAVELING

Check the direction

If forward movement and backward movement are mistaken in operation with the travel lever, serious accidents may result.

Check the blade position before traveling. If the blade is behind the machine, operations of the travel levers are reversed.

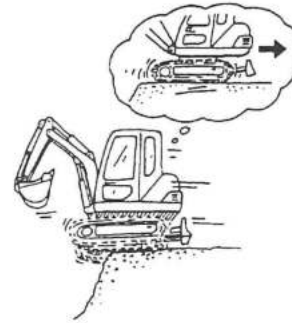

WC-C100340

Travel up and down the slope

Traveling sideways or parallel to a slope while on it may cause the machine to slide and fall over.

To prevent such accidents, only travel up and down the slope at a right angle.

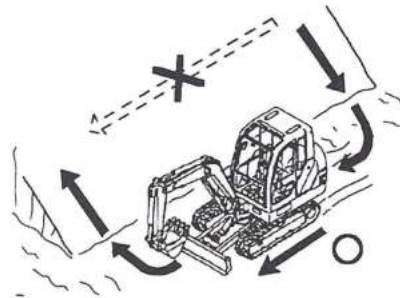

WC-C100350

Do not steer on the slope

Avoid changing the direction on a slope, which could result in tipping or side slipping of the machine.

When it is inevitable to change the direction, carry it out in a hard ground where the slope is gradual.

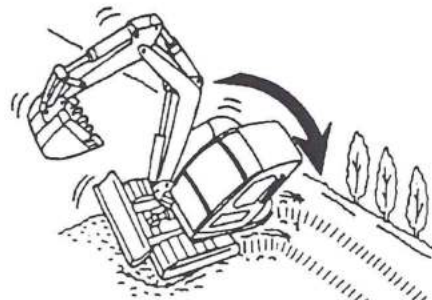

WC-C100370

Travel on the slope

- Keep the bucket at as low position as 20 to 30 cm from the ground and travel the machine at low speed when traveling on a slope.
- Lower the bucket onto the ground and stop traveling if the machine becomes unstable.

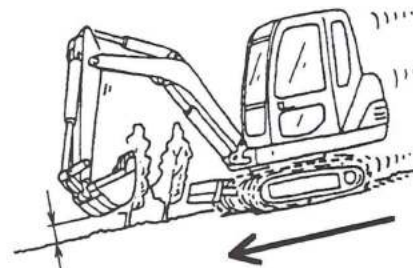

20~30cm

WC-C100390

SAFETY

PRECAUTIONS FOR TRANSPORTING

Load and unload the machine

- Always load and unload the machine on the level ground.
- Use a ramp board that has sufficient strength, width, length, and thickness.
- Remove ice, snow, or slippery material from the ramp board and truck deck before loading.
- Never swing the machine on a ramp board. Otherwise, it may fall down.

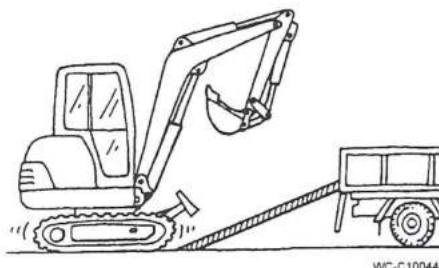

Never load or unload the machine without ramp board

Never load or unload the machine by jacking up the attachment. Otherwise, the machine may fall down.

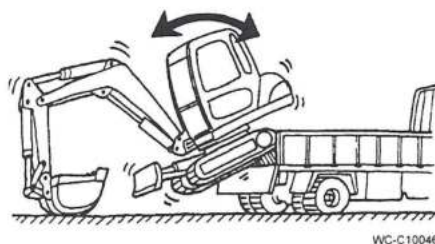

Precautions at transportation

Apply stoppers in front of and behind the crawlers.

Apply wire ropes to the machine body and attachment and fix them firmly to the load carrying platform.



SAFETY

PRECAUTIONS FOR MAINTENANCE

Keep routine maintenance

You must read and understand the warnings and instructions contained in this manual, before performing any operation or maintenance procedures.

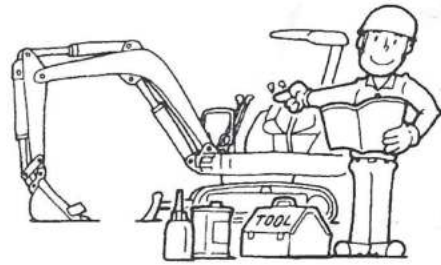

WC-C100450

Wear protective tools

In grinding or when detaching the pin or tooth, fragments may be put in eyes, resulting in injury.

Wear protective goggles and protective cap before starting work.



WC-C100590

Put the "maintenance signboard"

Put the "Maintenance signboard" on an easy-to-see position of the operation lever in order to prevent any other person from touching the machine carelessly.



WC-C100490

Never perform maintenance of the moving machine

Lower the bucket onto the ground and stop the engine to prevent an accident of being crushed or caught by the machine.

Keep in good contact with the operator if it is necessary to perform maintenance of the moving machine.

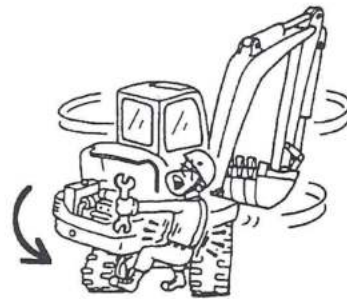

WC-C100500

SAFETY

When working under tracks

If the machine is merely jacked up with the attachment, you may be caught by the machine when it lowers. Place the supporting blocks under the crawler and make sure that it is supported firmly.

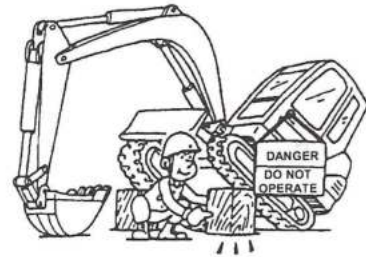

WC-C100520

Hold the attachment

If the hydraulic hose is disconnected or the pin is drawn out in the condition where the attachment is raised in the air, oil may spout out or the attachment may drop. Be sure to lower the attachment onto the ground or keep it with safety supports, blocks, etc.

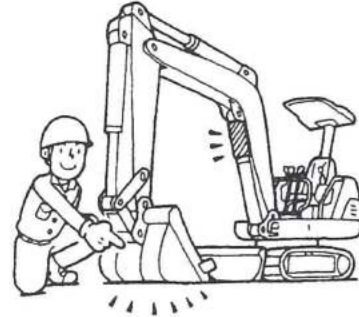

WC-C100540

Never watch the check valve when adjusting crawler shoes

Never watch the check valve when servicing the crawler shoes. Position yourself not to be splashed with grease. Grease used to adjust the crawler shoes is highly pressurized and can cause serious injury or death. Carefully read and understand the maintenance procedure for shoe adjustment.

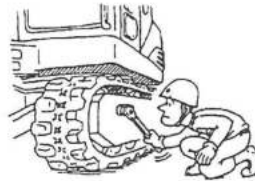

WC-C100580

Never perform maintenance with engine running

Touching rotating parts such as the fan belt, etc., can get your hand crushed and there is the danger of your hand being cut off.

Always perform maintenance with the engine shut off.



WC-C100510

Be careful with hot engine

Never touch the engine or muffler right after the machine is stopped. It is very hot and causes burns.



WC-C100530

SAFETY

Never open a radiator cap when it is hot

Never try to open the radiator cap while the engine is running or right after the engine is stopped. If the cap is open the very hot steam will blow out, which causes serious burns.

Wait until the coolant temperature goes down.

Slowly open the cap to release the pressure.

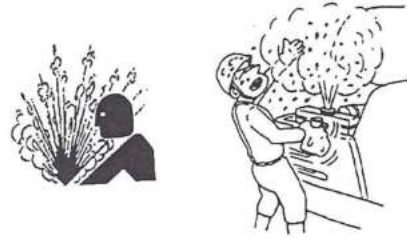

WC-C100550

Always release inner pressure from hydraulic system

Pressurized oil may spout out if the hydraulic line is disconnected without releasing the inner pressure of the hydraulic system. Release the inner pressure before disconnecting a hydraulic line.



WC-C100560

Precautions for high pressure oil

It is very dangerous if the high pressure oil enters your skin or eyes.

If oil enters your skin, immediately go to the doctor and get medical attention.

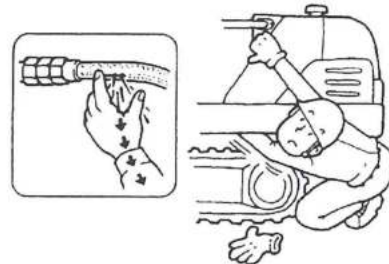

WC-C100570

Precautions for battery

When maintaining the electrical system or carrying out welding, remove the lead connected to the negative terminal (-) of the battery.

The battery can generate flammable gases and there is the danger of the gases catching fire and exploding. Also, dilute sulfuric acid is used for the battery liquid. Take sufficient care while handling.

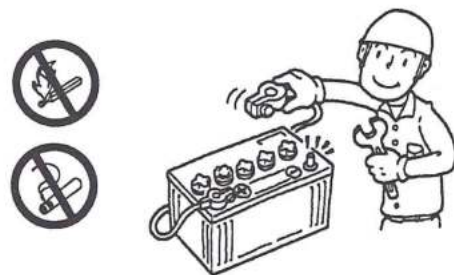

CA-C100370

Prevent fire or explosions

Keep away fuel, lubricant and coolant from any fire or heat. Most of them are very flammable.

Never place flammable materials or objects close to fire or heat.



WC-C300020

SAFETY

SAFETY SIGNS AND LABELS

There are several specific safety signs  on your machine. Make sure that you can read all safety signs. Clean or replace these if you cannot read the words.

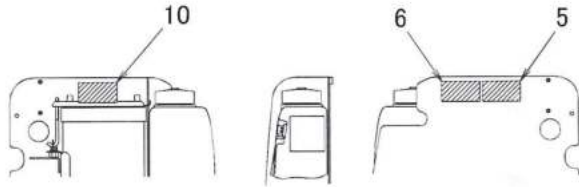

View C

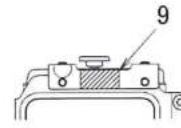

View D

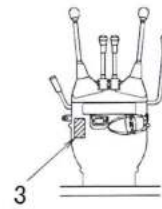
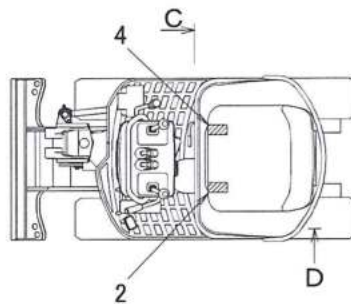

View B

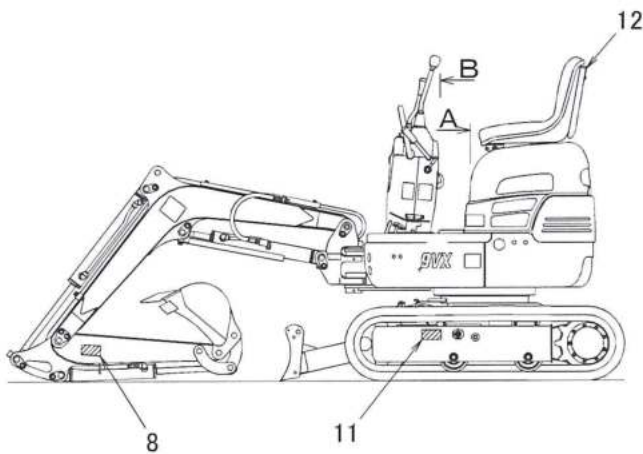

Put into the pocket on the back of the seat.

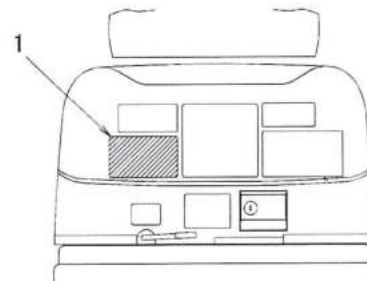
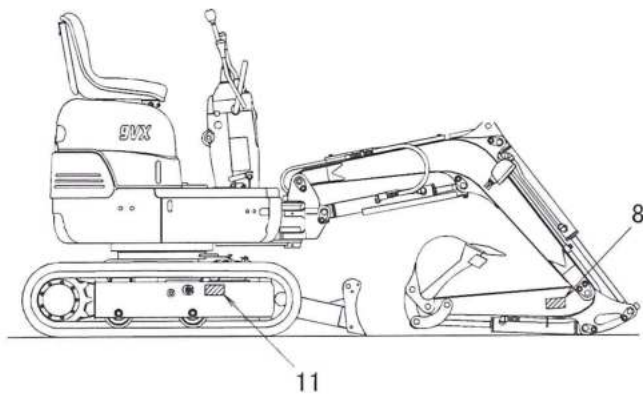
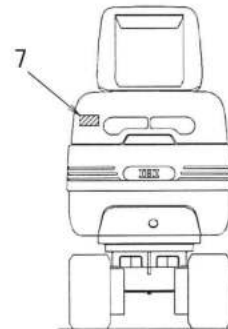

View A

SAFETY

1. Safety (440590300)

operation

SAFETY OPERATION

1. Before and after everyday's operation, make sure to do daily inspection, lubrication and maintenance.
2. During operation, make sure all lamps are in normal condition and pay special care that people and any obstacles are well clear the machine.
3. Down the bucket on ground and stop the engine when machine is not in use.
4. When travelling on rough ground, try to level the ground as much as possible.
5. Do not squeeze-in below the machine being raised up, by boom.
6. Do not use the bucket like a pickax, hammer or a broom.
7. Avoid to park the machine on inclined ground as much as possible. If not avoidable, put suitable block on the crawler shoes and down the blade to penetrate ground.

440590300

440590300

2. Read manual !
(D405 359 00)
Read manual before operation, maintenance, disassembly, assembly and transportation.



3. Crush hazard
(D405 508 00)
Sign indicates a hazard of being crushed or run over by unexpected moving of stopped machine.



Lower working device to ground, move safety lever to lock position and take engine key with you before leaving machine.

4. Electric power lines
(D405 506 00)
Sign indicates an electrocution hazard if machine is brought too near electric power lines. Keep a safe distance from electric power lines.



SAFETY

5. Hazard of rotating parts (D405 675 00)

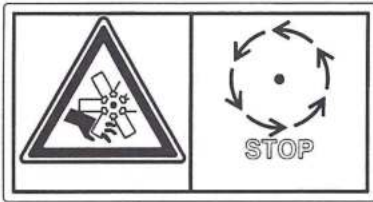

Sign indicates a hazard of rotating parts, such as fan. Turn off before inspection and maintenance.

6. Hazard of rotating parts (D405 674 00)

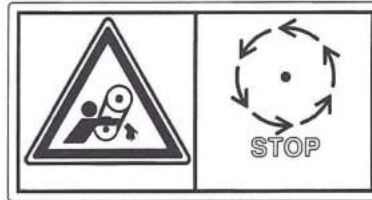

Sign indicates a hazard of rotating parts, such as belt. Turn off before inspection and maintenance.

7. Keep away from swing area (D406 269 00)

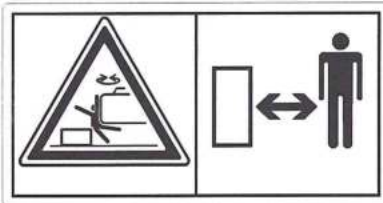

Sign indicates a crush hazard by rotation of upper structure of the machine. Keep away from swinging area of machine.

8. Keep away from machine (D405 668 00)
Sign indicates a hazard of being hit by the working device of the machine.



9. Burn hazard (D405 503 00)



Sign indicates a burn hazard from spurting hot water or oil if radiator or hydraulic tank is uncapped while hot. Allow radiator or hydraulic tank to cool before removing cap.

10. Electrical hazard (D405 504 00)

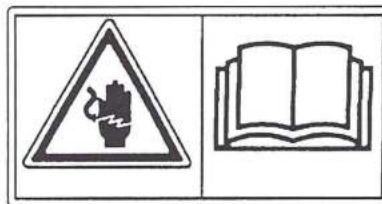

Sign indicates an electrical hazard from handling the cable. Read manual for safe and proper handling.

SAFETY

11. Warning for track adjuster 12. Danger !
(D405 505 00) (D405 323 00)

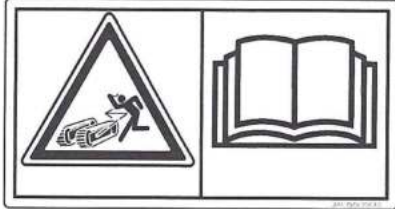

D40550500

Sign indicates a hazard of flying plug from track adjuster that could cause injury. Read manual before adjusting track for safe and proper handling.



D40532300

Operation prohibition during inspection and servicing. Hang this sign on the control lever during inspection and servicing not to allow any other worker to start the engine or operate the machine.

OPERATION

This section describes the proper operation procedures of this machine.

Always look to the safety and observe the given operation instructions and cautions to carry out works safely.

OPERATION

NAMES OF COMPONENTS

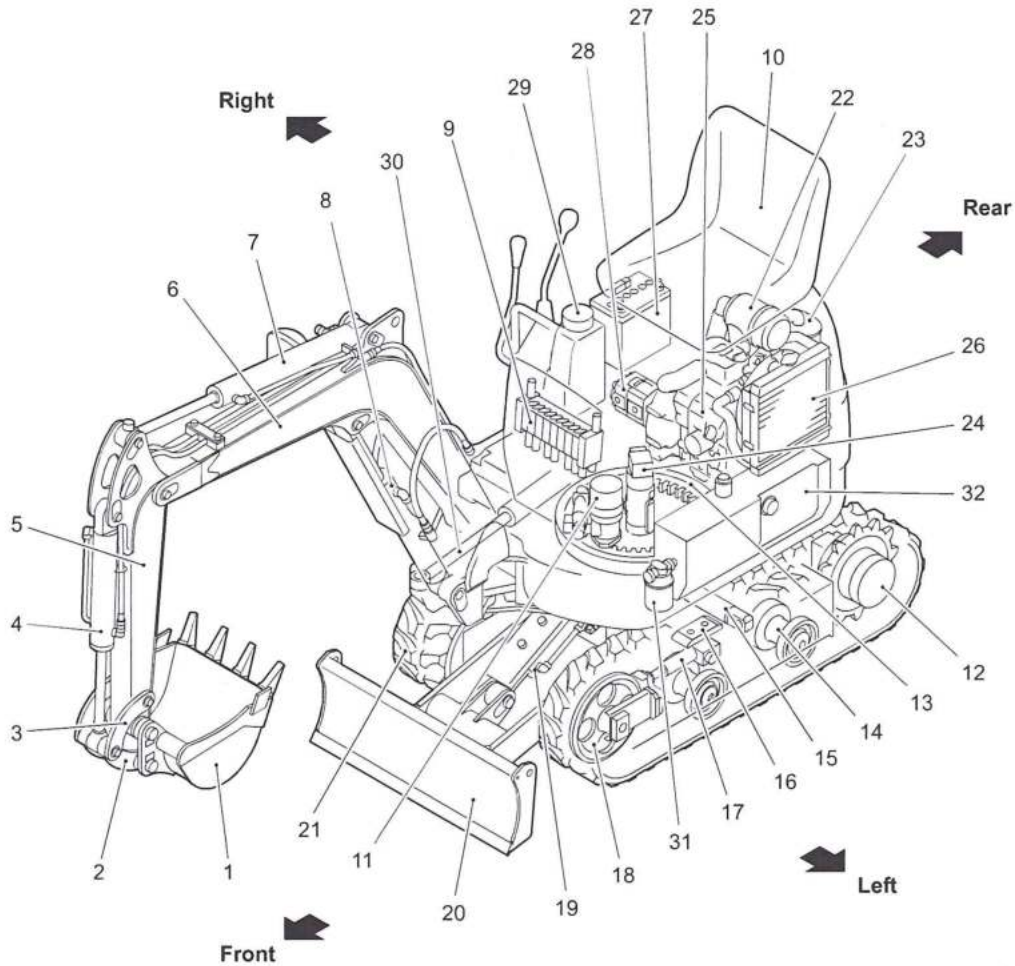

WB-C210010

No.	Name	No.	Name	No.	Name
1	Bucket	12	Travel motor	23	Muffler
2	Bucket link	13	Swing bearing	24	Rotary joint
3	Arm link	14	Lower roller	25	Engine
4	Bucket cylinder	15	Crawler extension cylinder	26	Radiator
5	Arm	16	Slide pad	27	Battery
6	Boom	17	Shoe adjusting device	28	Hydraulic pump
7	Arm cylinder	18	Front idler	29	Fuel tank
8	Boom cylinder	19	Blade cylinder	30	Boom swing cylinder
9	Control valve	20	Blade	31	Return filter
10	Operator's seat	21	Crawler shoe	32	Hydraulic oil tank
11	Swing unit	22	Air cleaner		

OPERATION

CONTROLS AND INSTRUMENTS

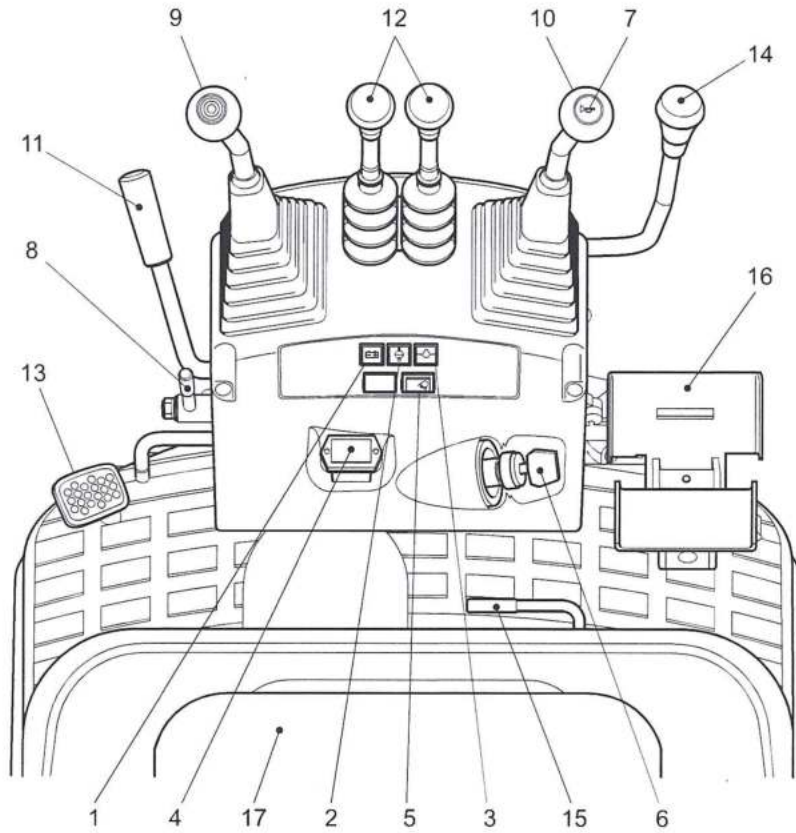

WB-C210020

No.	Name	No.	Name
1	Battery charge warning lamp	10	Right operation lever
2	Water temperature warning lamp	11	Throttle lever
3	Engine oil pressure warning lamp	12	Travel lever
4	Hour meter	13	Travel speed select pedal
5	Light switch	14	Blade/crawler operation lever
6	Engine key switch	15	Blade/crawler select lever
7	Horn switch	16	Boom swing pedal
8	Operation lock lever	17	Operator's seat
9	Left operation lever		

OPERATION

1. Battery charge warning lamp

This lamp turns on if some trouble occurs in the charging system while the engine is running. Stop the engine and check if the fan belt is not slack and the electric system is proper, if this lamp turns on while the engine is running.

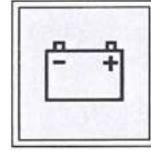

WB-C210030

2. Water temperature warning lamp

This lamp turns on if the cooling water temperature exceeds 107 °C while the engine is running. Bring the engine into the idling state to cool down the cooling water if this lamp turns on while the engine is running. Stop the engine and check the cooling system and the cooling water level after the cooling water temperature lowers.

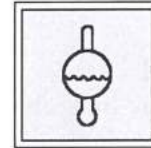

WB-C210040

3. Engine oil pressure warning lamp

This lamp turns on if the lubricating oil pressure lowers while the engine is running. Stop the engine and check the lubrication system and lubricating oil quantity if this lamp turns on while the engine is running.

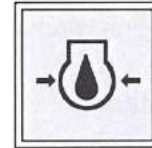

WB-C210050

4. Hour meter

- The accumulated operation time of the machine is displayed in units of 1/10 hour (6 minutes).
- While the engine is running, the green operation indicator on the right of the meter rotates, indicating that the meter proceeds.
- It advances as long as the engine is running, even if the machine is not working.

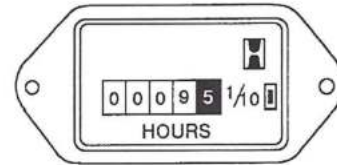

WB-C210060

5. Light switch

The front light of the boom turns on when the  mark is pressed. It turns off when the opposite side is pressed.



WB-C210070

OPERATION

6. Engine key switch

Use this switch to start and stop the engine.

HEAT (preheat)

The HEAT position is used to preheat the cool engine in cold seasons. Preheating is complete by holding the switch at the HEAT position for approximately 4 seconds. Turn the key to the START position then.

OFF (stop)

The key may be inserted and drawn out at this position. All electric system switches are off and the engine stops.

ON (run)

The electric system is powered on and the warning lamp turns on. Keep the switch at this position while the engine is running.

START (start)

Set the switch to this position to start the engine.
Release the fingers from the key immediately after the engine starts.
The key returns to the ON position automatically.

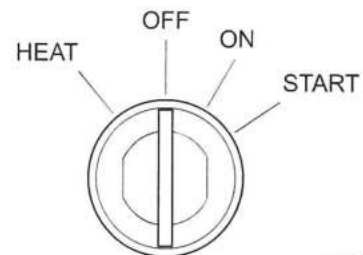

WB-C210080

7. Horn switch

Press this switch to turn on the horn.

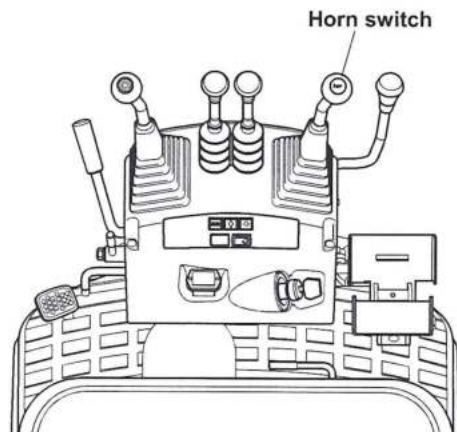

WB-C210090

OPERATION

8. Operation lock lever

- This lever is a safety device, which prevents the machine from malfunctioning if the operator's body touches the operation lever when getting on or off the machine.
- Attachment operation and swing operation are locked when the operation lock lever is set to the LOCK position.
- Set the operation lock lever to the UNLOCK position when starting work.

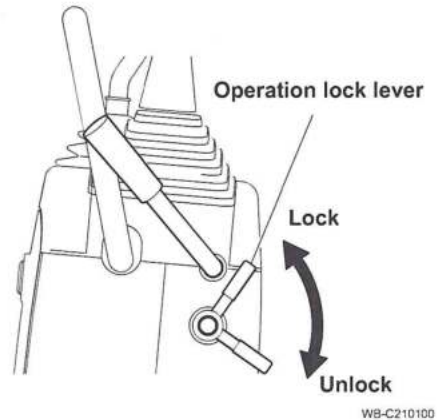

! WARNING

- The machine may move in an unexpected way and a serious accident may result, if you touch the operation lever carelessly in the condition where the operation lock lever is not set at the LOCK position.
- Stop the engine and set the operation lock lever to the LOCK position before leaving the machine.
- Note that boom swing operation is not locked even if the operation lock lever is set to the LOCK position.

OPERATION

⚠ WARNING

This manual gives explanations of the standard operation system (JIS system).

In some types of machines, the actual operation systems may differ from the given explanations.

Improper operation may cause a dangerous accident. Make sure, before starting operation, that machine movements are the same as shown on the operation system label.

9. Left operation lever

Use this lever to operate the arm and swing.

- Arm in: Pull the lever backward.
- Arm out: Push the lever forward.
- Swing left: Turn the lever to the left.
- Swing right: Turn the lever to the right.
- Stop: Release your hand from the lever. The lever returns to the neutral position automatically and operation stops.
- Simultaneous operation: Turn the lever diagonally to operate the arm and swing simultaneously.

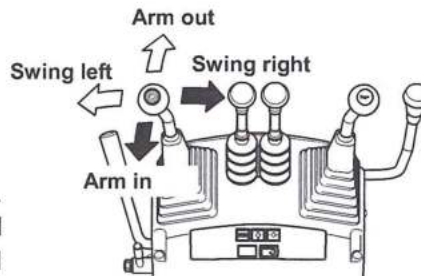

WB-C210110

10. Right operation lever

Use this lever to operate the boom and bucket.

- Boom raise: Pull the lever backward.
- Boom lower: Push the lever forward.
- Bucket dig: Turn the lever to the left.
- Bucket dump: Turn the lever to the right.
- Stop: Release your hand from the lever. The lever returns to the neutral position automatically and operation stops.
- Simultaneous operation: Turn the lever diagonally to operate the boom and bucket simultaneously.

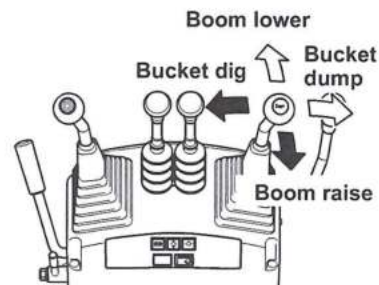

WB-C210120

11. Throttle lever

Use this lever to adjust the engine speed.

- Low speed: Push the lever forward.
- High speed: Pull the lever backward.

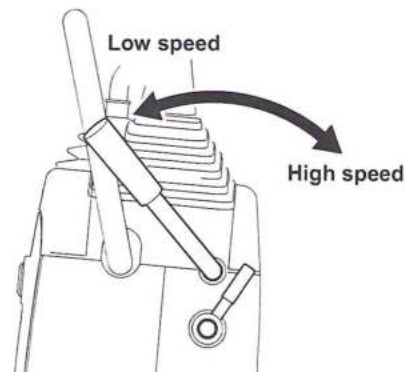

WB-C210130

OPERATION

12. Travel Levers

Use these levers to control traveling.

Forward: Push the right and left travel levers forward.

Backward: Pull the right and left travel levers backward.

Stop: Release your hands from the levers. The levers return to the neutral positions automatically and operation stops.

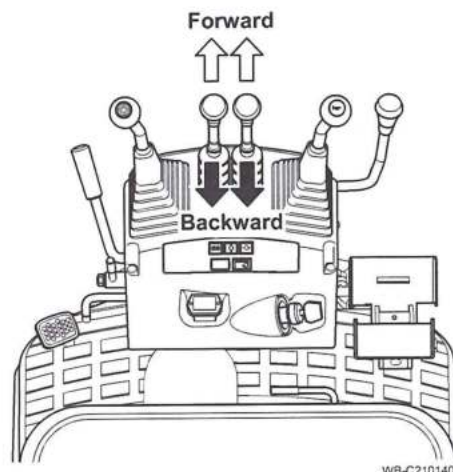

WARNING

- If forward movement and backward movement are mistaken during traveling, a serious accident may result.
- Forward movement means forward movement with the blade in the front position. If the blade is at the rear position, the traveling directions are contrary to the lever operations.
- Check if the blade is in the front or rear position before operating the travel levers.

13. Travel speed select pedal

CAUTION

Do not travel the machine at the high speed when loading it on a truck or traveling on a steep slope.

The travel speed changes into the high speed when you step on the pedal. The high speed changes into the low speed when you release your foot from the pedal. The travel speed may be changed during traveling or stopping.

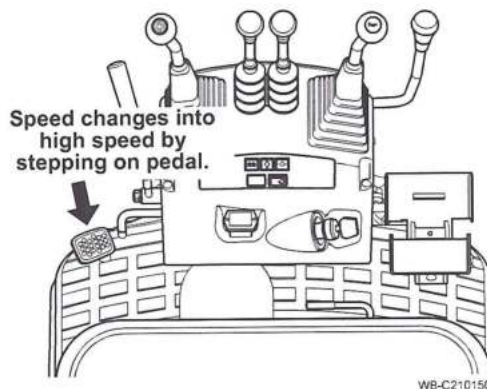

OPERATION

14. Blade/crawler operation lever

CAUTION

The blade moves down by its own mass if this lever is pushed forward even though the engine is stopping, if the blade/crawler lever is set at the blade position.

- Blade operation
Blade raise: Pull the lever backward.
Blade lower: Push the lever forward.
- Crawler operation
Crawler retract: Pull the lever backward.
Crawler extend: Push the lever forward.

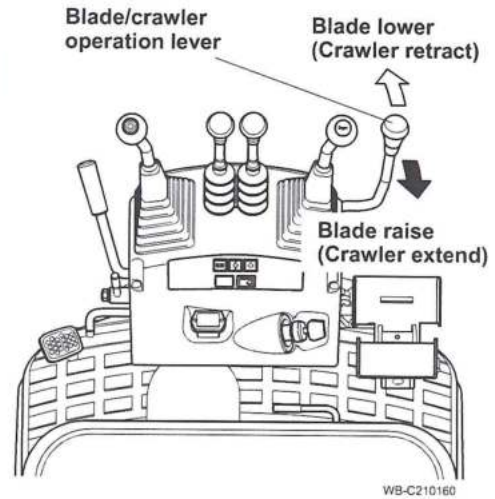

15. Blade/crawler select lever

Change blade operation and crawler operation with this lever.

- Blade operation: Push down the lever.
Crawler operation: Pull up the lever.

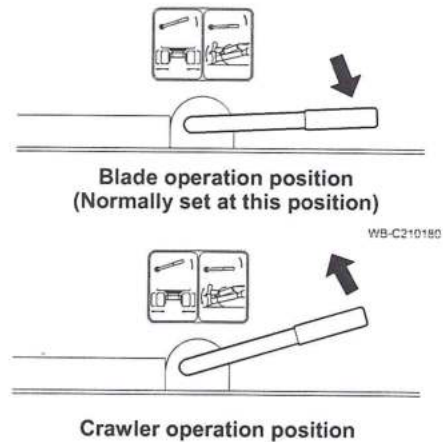

16. Boom swing pedal

- Swing the boom with this pedal.
Open the pedal cover to the unlock position.
Boom swing left: Step on the left side of the pedal.
Boom swing right: Step on the right side of the pedal.

CAUTION

Protect the pedal with the cover to disable pedal operation when boom swing operation is not needed.

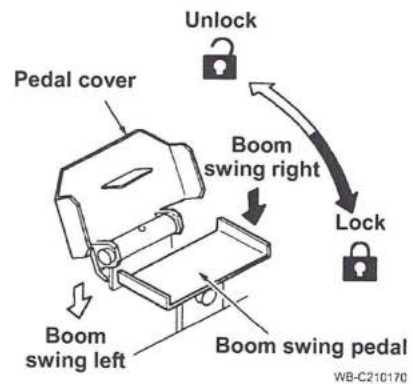

OPERATION

STARTING ENGINE

Check before Starting Engine

1. Sit on the operator's seat and adjust it to the condition where the operation levers and pedals may be used smoothly.
2. Make sure that the operation lock lever (1) is set at the locked position.
3. Make sure that each lever is set at the neutral position.
4. Insert the key into the engine key switch (2). Turn it to the ON (run) position and make sure of the following.
 - The engine oil pressure warning lamp (3) and battery charge warning lamp (4) are lit continuously (it is normal if the engine oil pressure warning lamp and battery charge warning lamp turn off when the engine starts).
 - Push the light switch (5) and make sure that the front light is turned on.
 - Push the horn switch (6) and make sure that the horn sounds.

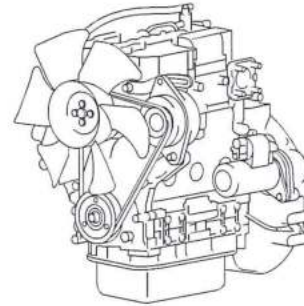

WC-C201220

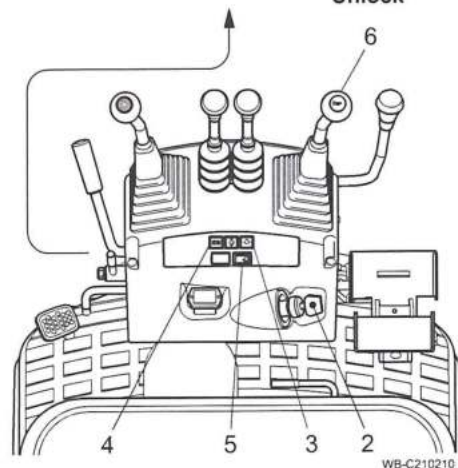
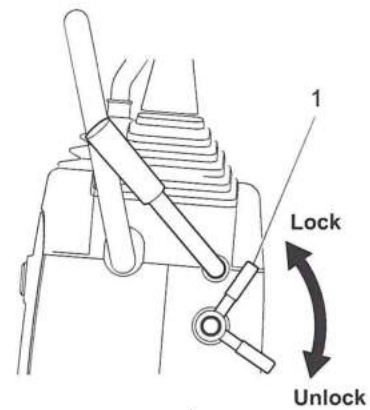

WB-C210210

OPERATION

Normal Starting

1. Set the throttle lever to the middle speed.
2. Turn the engine key to the START position to start the engine.
3. Release your fingers from the key when the engine starts.
The key returns to the ON (run) position automatically.
4. Push the operation lock lever down to the unlock position to start work.

CAUTION

- Check if there are no persons or obstacles around the machine, turn on the horn, and start then.
- Be sure to sit on the operator's seat and start the engine.

NOTICE

Do not turn the starting motor for 15 seconds or more. If the engine fails to start, return the key to the OFF position, wait for 30 seconds, and try to start the engine again.

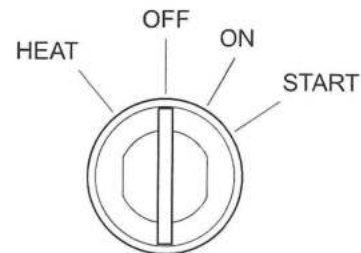
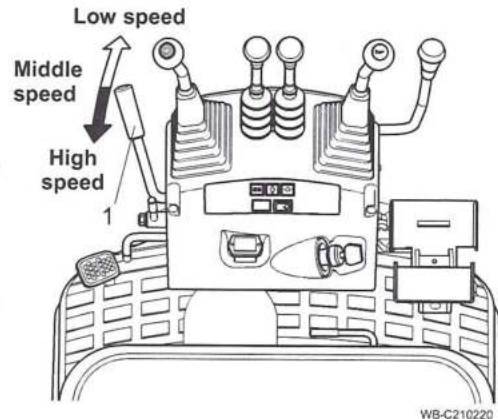

Starting in Cold Seasons

Preheat the engine with the glow plug in cold seasons to make it easy to start the engine.

1. Set the throttle lever (1) to the middle speed.
2. Turn the key counterclockwise and keep it at the HEAT (preheat) position for about 4 seconds. The engine oil pressure warning lamp and battery charge warning lamp also turn on when the key is set at the HEAT (preheat) position. However, this does not imply any abnormality.
3. Turn the key to the START position to start the engine.
4. Release your fingers from the key after the engine starts. The key returns to the ON (run) position automatically.

OPERATION

Starting Engine with Booster Cables

Follow the instructions shown below to start the engine using the booster cables.

! WARNING

- If the booster cables are connected improperly, the battery will be shorted, resulting in a dangerous accident. Never connect the \oplus and \ominus terminals.
- The battery produces flammable hydrogen gas, which is explosive. Do not bring fire close to it or produce sparks near it.

NOTICE

The electrical circuits of this machine run on 12 V. Use a 12 V auxiliary battery.

Order of connecting booster cables

1. Set the engine key switches of the normal machine and machine in trouble to the OFF positions.
2. Connect the clip of the booster cable (red) to the \oplus terminal of the machine in trouble. Connect the other clip to the \oplus terminal of the normal machine.
3. Connect the clip of the booster cable (black) to the \ominus terminal of the normal machine. Connect the other clip to the upper frame of the machine in trouble.

Starting engine

1. Make sure that the cable clips are connected to the battery terminals and upper frame firmly.
2. Start the engine of the normal machine and keep the engine running at high revolution.
3. Start the engine of the machine in trouble.

Disconnecting booster cables

1. Disconnect the clip of the black cable from the upper frame first. Then, disconnect the clip from the \ominus terminal of the normal machine.
2. Disconnect the clip of the red cable from the \oplus terminal of the normal machine first. Then, disconnect the clip from the \oplus terminal of the machine in trouble.

Never connect the \oplus and \ominus terminals

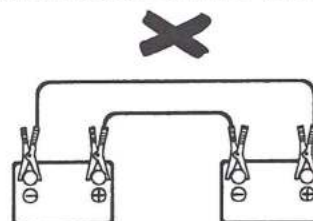

WC-C200410

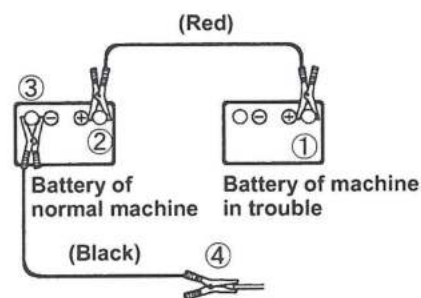

Upper frame of machine in trouble

Order of connecting booster cables



WC-C200420

Order of disconnecting booster cables



CA-C300120

OPERATION

Check after Starting Engine

1. Make sure that all warning lamps are off.
2. Check if the engine exhaust color, sound and vibrations are proper.

NOTICE

- Do not accelerate the engine or apply loads to it quickly when the cooling water temperature is low.
- Stop the engine immediately, find the cause and repair troubles, if some troubles are found.

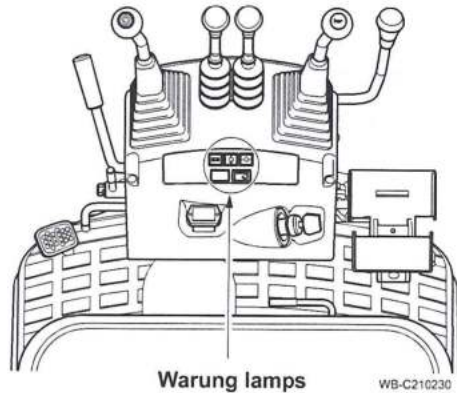

Warung lamps

WB-C210230

Warming Up Engine

1. Idle the engine to warm it up for approximately 10 minutes after the engine starts.
2. Lift the bucket from the ground and repeat cycles of moving the bucket lever to the digging or dumping position for 10 to 15 seconds and keeping it at the neutral position for about 10 seconds for five minutes to raise the hydraulic oil temperature, if the hydraulic oil temperature is low.
3. Then, repeat all operations, including swinging, traveling and moving the attachment, three to five times to warm up all devices.



Warming up

WC-C200430

NOTICE

Do not carry out high-speed operation quickly when the hydraulic oil temperature is low (below 20°C).

The proper hydraulic oil temperature is 50°C to 80°C. Warm up hydraulic oil up to 20°C or so and then carry out operation, if it is necessary to start operation at low temperature.

STOPPING ENGINE

WARNING

If you touch the operation lever by mistake without locking the operation lock lever, the machine may move unexpectedly, resulting in a dangerous accident.

Lower the attachment onto the ground, stop the engine and set the operation lock lever to the lock position before you leave the operator's seat.

• Stopping machine

1. Park the machine on a safe, flat and rigid ground not in danger of stone dropping, landslide, etc.
2. Raise the arm and lower the bucket onto the ground with its bottom horizontal.
3. Lower the blade onto the ground.
4. Set the gate lock lever to the locked position.



WC-C200440

• Stopping engine

1. Idle the engine for five minutes or so to lower the engine temperature.
2. Set the engine key switch to the OFF (stop) position to stop the engine.
3. Pull out the key from the engine key switch.

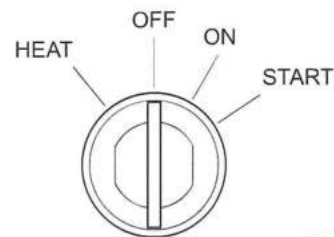

WB-C210080

• Inspection and locking after engine stops

1. Check each part for oil leak, water leak and damages. Carry out repair work if leak or some abnormality is found.
2. Refill the fuel tank fully.
3. Remove soil and sand from around the crawlers and bucket.
4. Lock all the lockable parts such as the fuel port, engine cover, etc.



WC-C200450

OPERATION

RUNNING IN NEW MACHINE

NOTICE

If a new machine is used by force, the performances may be deteriorated earlier and the service life may be shortened. Run in the machine for the initial 50 hours.

Follow the instructions below and run in the new machine.

1. Warm up the machine sufficiently.



WC-C200430

2. Do not run the machine with heavy loads or at high speed.

Run the machine at about 80% of the maximum engine revolution.

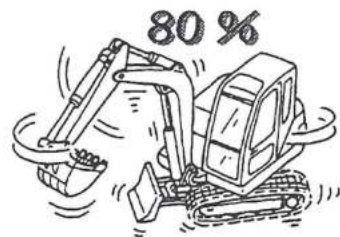

WC-C200460

3. Do not apply the full load to the machine. The adequate load is 80% or so. Do not run the machine by force.
4. Do not start, accelerate or stop the machine quickly or change the direction quickly.
5. Do not apply shocks such as quick stopping of the boom when lowering it to the machine.
6. Grease the pins of the attachment everyday.



WC-C200470

OPERATION

LEVER OPERATIONS

Operation Mode

Three operation patterns are available. The handling methods of the operation levers and machine movements differ with these patterns.

Check the operation mode before using the levers. The operation mode plate is stuck on the right of the operator's seat.

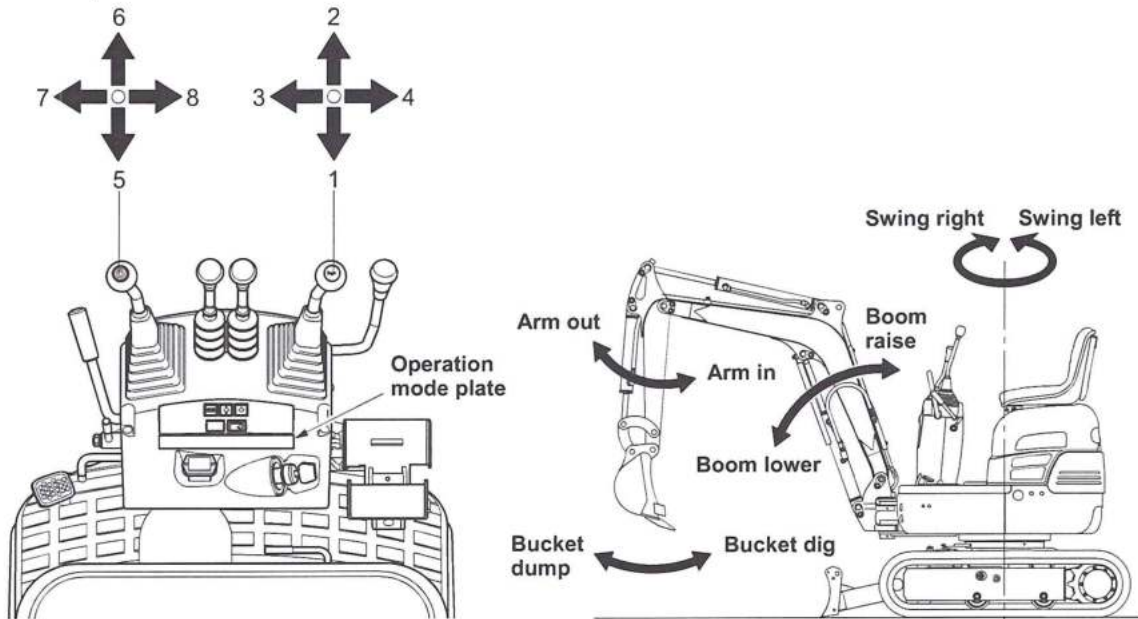

WB-C210270

Operation direction	Operation mode		
	Pattern A	Pattern B	Pattern F
1	Boom raise	Boom raise	Arm in
2	Boom lower	Boom lower	Arm out
3	Bucket dig	Bucket dig	Bucket dig
4	Bucket dump	Bucket dump	Bucket dump
5	Arm in	Swing left	Boom raise
6	Arm out	Swing right	Boom lower
7	Swing left	Arm out	Swing left
8	Swing right	Arm in	Swing right

⚠ WARNING

Check the action of each operation lever and movement of the machine before starting work in order to prevent accidents, which may result in injury or death, due to improper operations.

OPERATION

Operation Mode Plate

The operation mode plate shown below that indicates the operation system of the machine is stuck at the top of the lever stand on the operator's seat side.

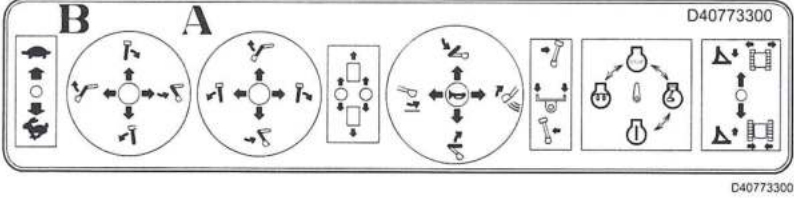
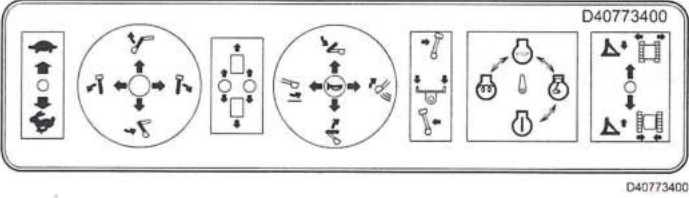
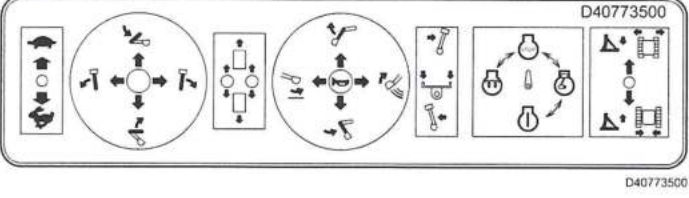
Operation mode	Operation mode plate
Pattern AB (AB select type)	
Pattern A	
Pattern F	

OPERATION

Pattern AB changing method

1. It is necessary to re-assemble the reach rods of the left operation lever, if the pattern A operation system (standard operation system) is changed into the pattern B. Open the cover on the front of the lever stand and re-assemble the reach rods.
2. The operation system changing plate is stuck on the inside of the lever stand front cover.
3. Lower the attachment onto the ground and stop the engine before re-assembling the reach rods.

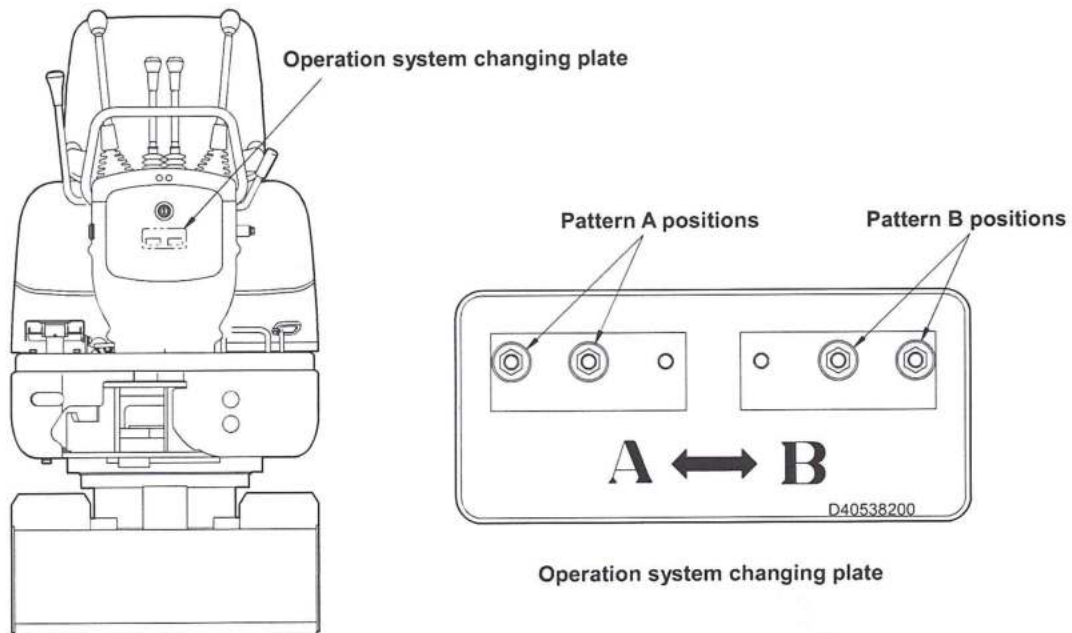
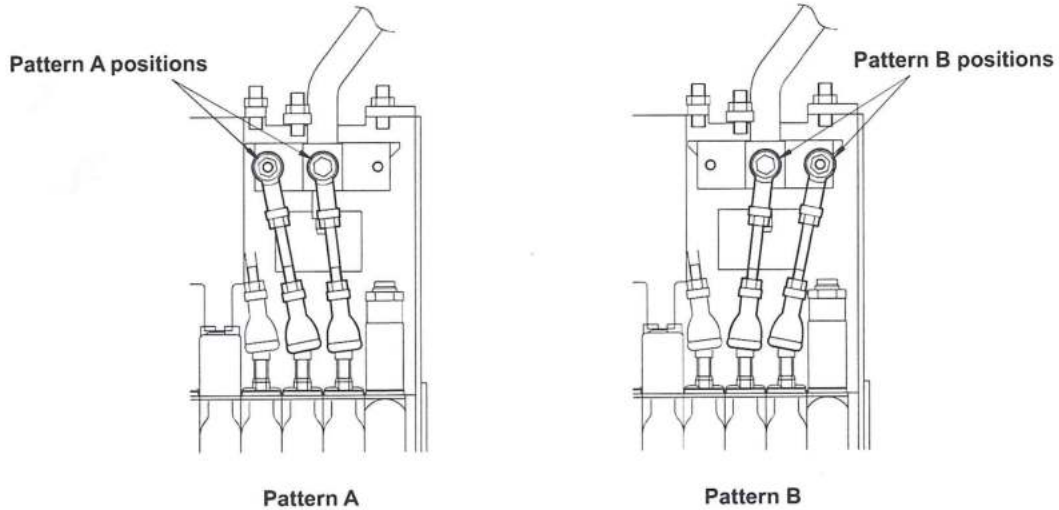

WB-C210280

OPERATION

CRAWLER EXTENSION/RETRACTION OPERATION

This machine has crawler extension/retraction mechanisms. Extend the crawlers as shown below.

1. Move the blade to the back of the machine and jack up the machine body until the crawlers are lifted from the ground using the attachment and blade in order to extend or retract the crawlers easily.
2. Pull up the blade/crawler select lever to the crawler operation position.
3. Change the engine speed to the middle speed and operate the blade/crawler operation lever. Extending the crawlers: Push the lever forward. Retracting the crawlers: Pull the lever backward.

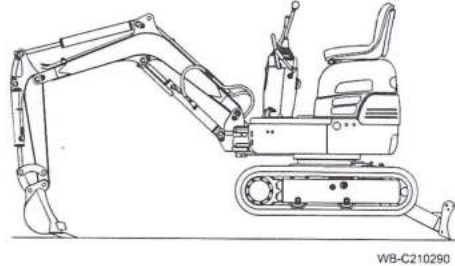

WB-C210290

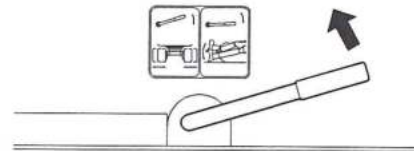

Crawler operation position

WB-C210190

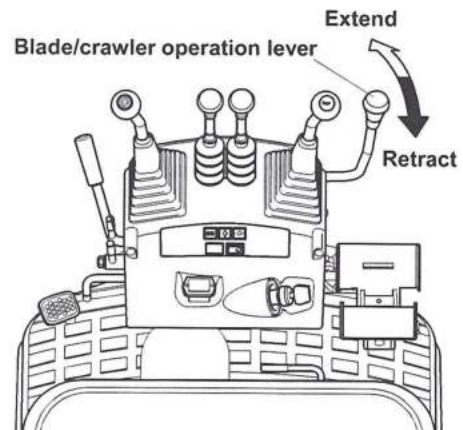

WB-C210300

NOTICE

Be sure to extend or retract the crawlers on a flat place with no obstacles.

The crawlers may be extended or retracted without jacking up the machine body. However, if there are obstacles on the ground on the side of the crawlers, the resistance increases and may hinder crawler extension or retraction.

CAUTION

- The crawlers may retract slightly during operation due to leakage from the hydraulic circuit. Extend them to the stroke end occasionally with the blade/crawler operation lever.
- Be sure to travel the machine at the stroke end of the crawler cylinder. If the machine is traveled at the middle of the stroke, the travel linearity and operability are deteriorated and the machine body may become faulty.

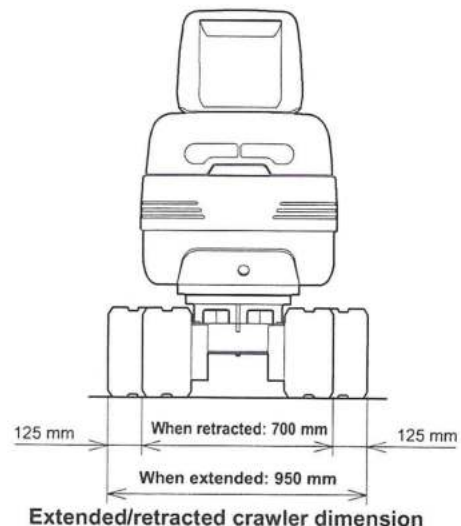

Extended/retracted crawler dimension

WB-C210310

OPERATION

BLADE OPERATION

Push down the blade/crawler select lever to the blade position and operate the blade/crawler operation lever.

Blade raise: Pull the lever backward.

Blade lower: Push the lever forward.

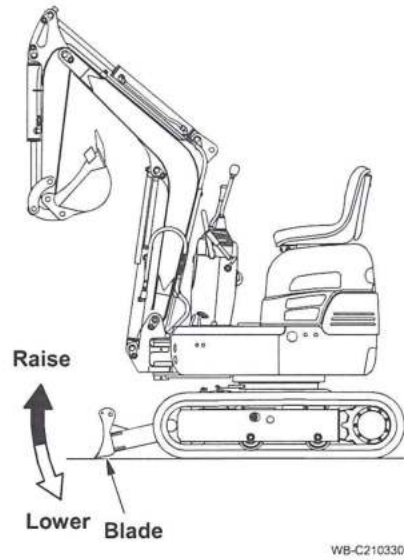
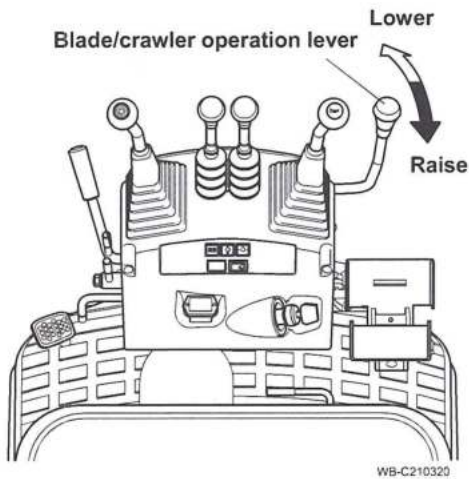

BOOM SWING OPERATION

Open the pedal cover to the unlock position before starting operation. Step on the right or left position of the boom swing pedal to operate the boom.

Right boom swing: Step on the right side of the pedal.

Left boom swing: Step on the left side of the pedal.

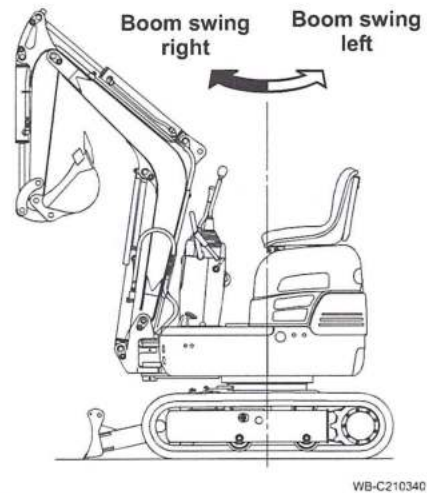
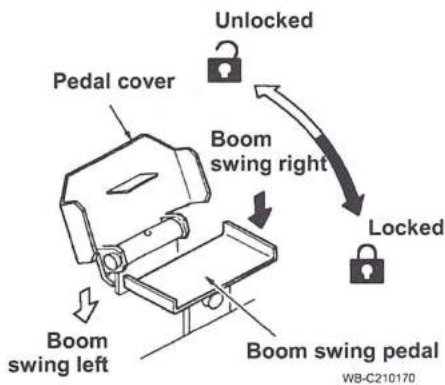

CAUTION

Put the pedal cover on the pedal and lock it when boom swing is not carried out.

OPERATION

SWING OPERATION

Use the left operation lever to swing.

Swing right: Turn the lever to the right.

Swing left: Turn the lever to the left.

Return the lever to the neutral position to stop swinging.

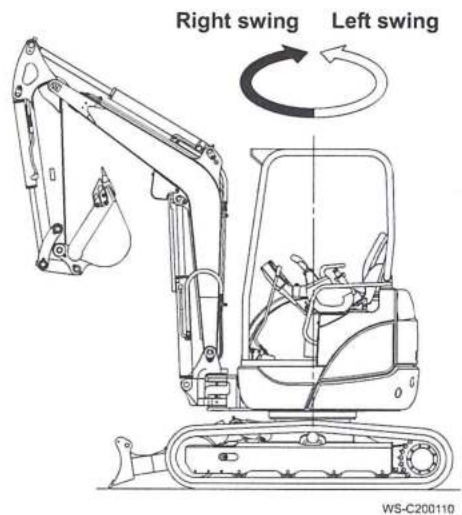
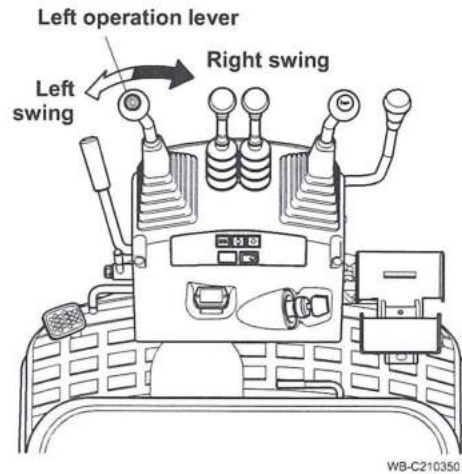

WARNING

Do not let any persons enter the swinging range.

Check the safety around the machine before swinging.

TRAVELING

Starting, Traveling and Stopping

! WARNING

- If forward movement and backward movement are mistaken in operation with the travel lever, serious accidents may result.
- Check the blade position before traveling. If the blade is behind the machine, operations of the travel levers are reversed.
- Make sure that there are no people around the machine and turn on the horn before starting.

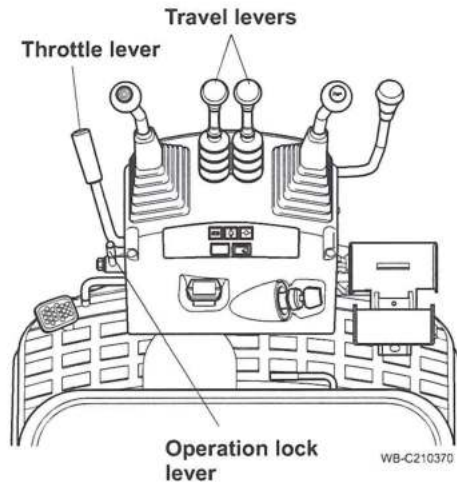

1. Pull the throttle lever to raise the engine speed to the proper speed to traveling.
2. Lower the operation lock lever to unlock it.
3. Raise the bucket and blade to certain height that allow smooth traveling without hitting them.
4. Operate the right and left travel levers as shown below.

• Forward

Push both travel levers forward to move the machine forward.

(The machine always moves toward the blade when the travel levers are pushed forward.)

• Backward

Pull back both travel levers to move the machine backward.

(The machine always moves toward the sprocket when the travel levers are pulled back.)

The traveling speed of the machine can be controlled by the amount of turning the travel levers.)

• Stopping

Set both travel levers to the neutral positions to stop the machine. When the machine stops, the parking brake is applied automatically.

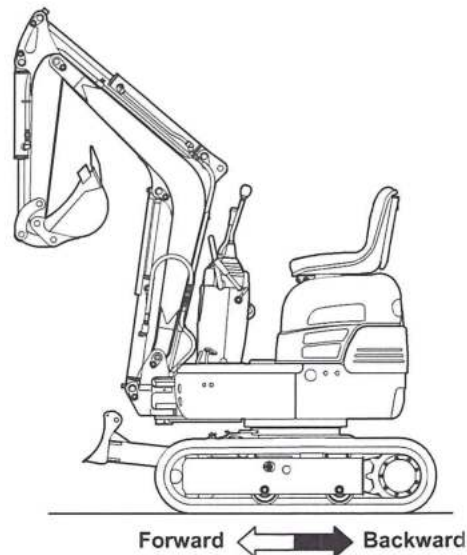
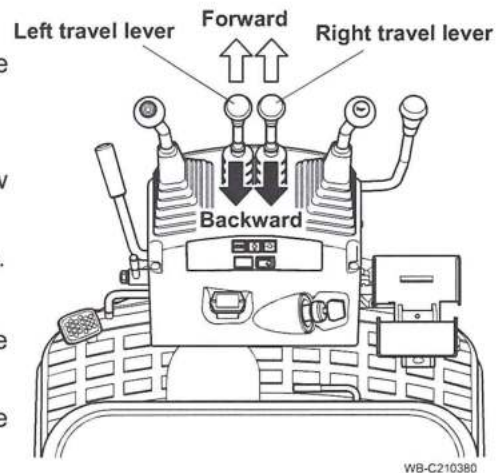

OPERATION

Changing Direction

Turning during traveling

Return the travel lever toward the neutral position a little to change the direction during forward (or backward) traveling.

When the lever of the intended turning direction is returned a little, the machine turns slowly in that direction.

Pivot turning (when blade is in front of machine)

Drive a single crawler to change the direction.

1. Pivot turn to the left
Push the right travel lever (1) to turn the machine forward. Pull it back to turn the machine backward.

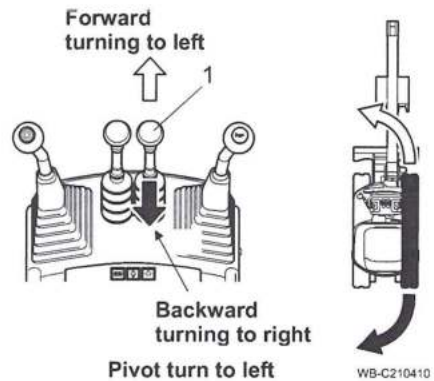

2. Pivot turn to the right. Use the left travel lever (2) in the same way.

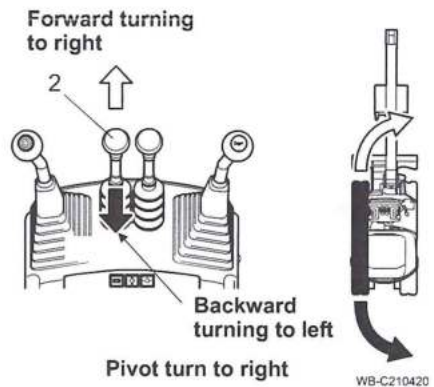

Spin turning (when blade is in front of machine)

Drive the right and left crawlers in the reverse directions to change the direction without traveling the machine.

1. Spin turning to the left.
Push the right travel lever forward and pull back the left lever.
2. Spin turning to the right.
Pull back the right travel lever and push the left lever forward.

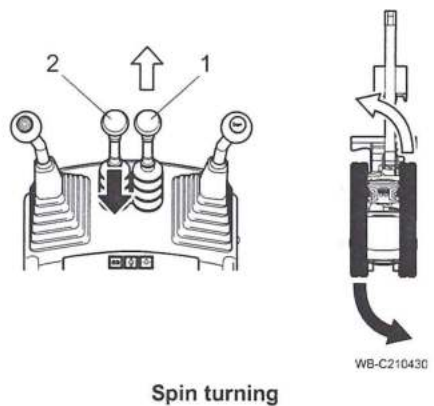

OPERATION

High speed Traveling

If you step on the travel speed select pedal, the speed changes into the high speed while you are stepping on the pedal.

The high speed changes into the low speed when you release your foot from the pedal.

WARNING

Do not change the travel speed into the high speed while unloading from a truck or traveling down a slope. It is very dangerous if the travel speed changes during traveling.

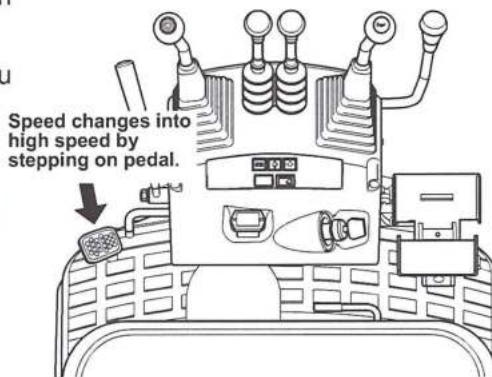

WB-C210150

Precautions While Traveling on Slope

1. The gradeability of this machine is 30° (58%).
2. Travel up or down a slope at the low speed.
3. Travel up a 15° or more slope in the posture shown on the right.
4. Reduce the engine speed and operate the travel levers slowly when traveling down a 15° or more slope. Move down the slope in the forward traveling posture as shown on the right. Lower the bucket onto the ground to stabilize the machine if it becomes unstable.

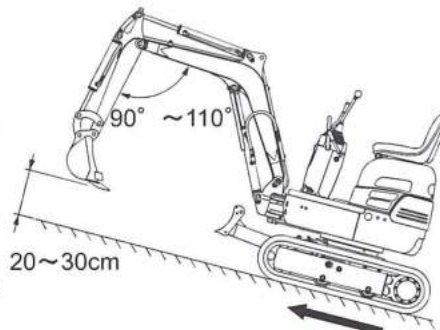

WB-C210450

WARNING

- Do not change the direction on a slope. Otherwise, the machine may slide sideways.
- When the machine moves across a slope, it may slide sideways. Move down the slope onto a flat ground, turn the machine, and travel safely.
- Do not travel on a 30° or more slope.

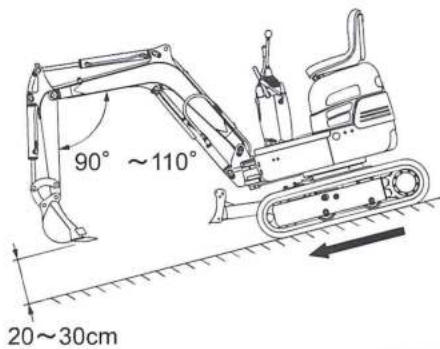

WB-C210460

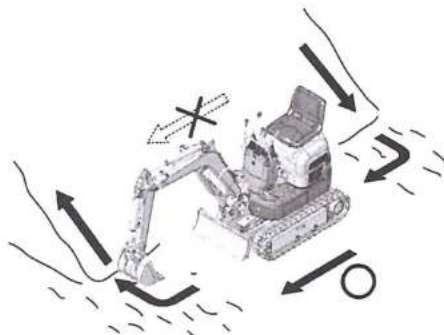

WB-C210440

OPERATION

WORK INSTRUCTIONS

Digging

The digging force of the arm cylinder is maximized when the angle between the arm cylinder and arm is 90 degrees.

The digging force of the bucket cylinder is maximized when the angle between the bucket cylinder and the arm link is the same as the angle between the arm link and bucket link.

Improve the digging work efficiency, making use of these angles properly.

In digging, pull the arm to dig with the bucket.
Raise and lower the boom to adjust the depth.

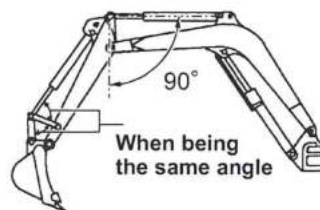

WC-C200700

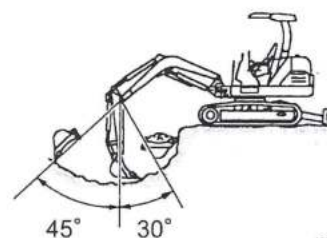

WC-C200710

Ditching

Place the machine along the ditch direction and travel it backward with the progress of ditching.



WC-C200720

Loading

After digging, raise the boom, swing and load soil onto the dump truck.

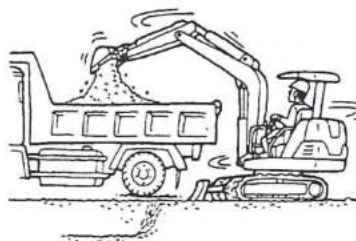

WC-C200730

Gutter Digging

It is possible to dig gutters in narrow spaces by swinging the boom.

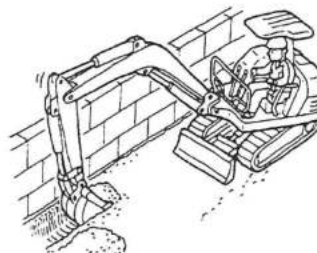

WC-C200740

OPERATION

PRECAUTIONS FOR WORKS

Never stop swinging by hitting

Never stop swinging by hitting or pressing the bucket against the wall of the ditch. Otherwise, strong impacts are applied to the machine and the service life is shortened.



WC-C200770

Never sweep with the bucket

Avoid sweeping the bucket like a broom in order to level off ahead of machine. This causes side strains and wear on the boom, arm, and bucket.

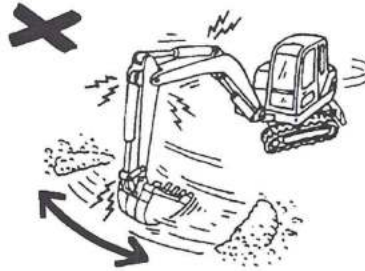

WC-C200780

Precautions for works at the cylinder stroke end

At the stroke end of the cylinder, the bucket moves faster. Thus, operate the bucket slowly with care not to allow soil and sand to drop.

When the cylinder is moved to the stroke end, large forces are applied to the cylinder piston and the service life is shortened. Give some margins to the cylinder in works.

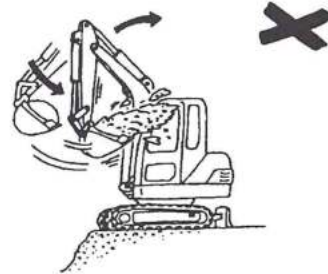

WC-C200790

Hammering is prohibited

Never use the bucket instead of picks or for hammering or piling. Otherwise, excessive forces are applied to the machine, resulting in dangerous accidents.

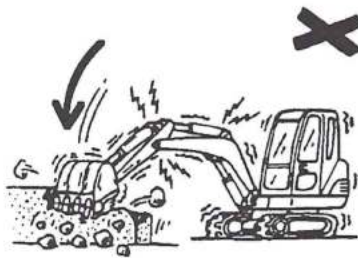

WC-C200800

Do not overload to cylinder

Do not forcefully conduct digging operation beyond the capacity, which may overload any cylinder and open its relief valves. This causes damage to the hydraulic system and machine.

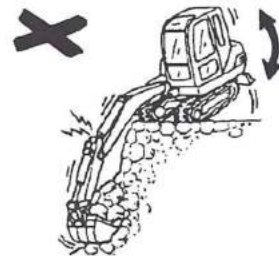

WC-C200810

OPERATION

Do not crawl with the bucket

Do not drag the bucket on the ground by crawling. Level the ground with proper equipments in a correct way.

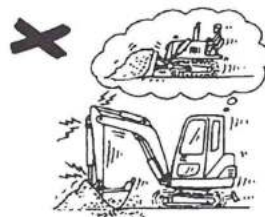

WC-C200820

Bring both sides of the blade into contact with the ground

Bring both sides of the blade into firm contact with the flat ground when using the blade as a stabilizing plate in digging work.

If a single side of the blade contacts the ground, the blade may be damaged.

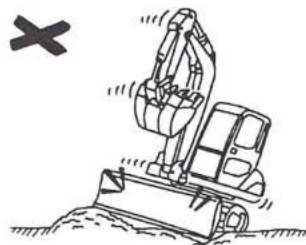

WC-C200830

Pay attention to the blade when digging deep ditches

The cylinder may hit against the blade. Thus, the boom cylinder may contact with the blade when digging a deep ditch.

Be very careful in operation.

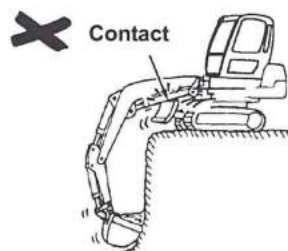

WC-C200840

Works in damp grounds

Place mats or the like to protect the footing in advance when carrying out works in damp grounds or muddy places.

Drive the machine with great care not to enter muddy places.



WC-C200850

OPERATION

Escape from a muddy place

If a single side enters a muddy place, lower the bucket onto that muddy ground to lift the crawler, place logs, wood, under the crawler and escape from that place.

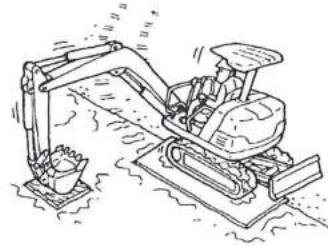

WC-C200860

If both sides enter a muddy place and the machine cannot be driven, place logs or wood under crawlers one by one in the same way as shown above, bite the front ground with the bucket, pull the arm in the same way as digging to move the machine, and escape from that place.

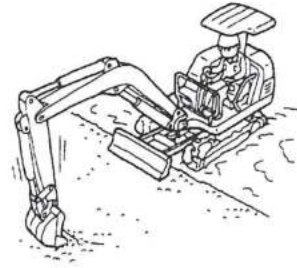

WC-C200870

Works in water

- The allowable water depth is up to the center of the upper roller or the top of the slide pad. Check the water depth and ground before working in water or traveling the machine across the river. Do not go into water deeper than the allowable water depth. The machine may sink little by little if the ground is soft. Pay great attention to the footing in work. If the bucket is dipped in water for long, grease the pins around the bucket sufficiently until used grease oozes out.
- The engine may get wet with water and the radiator fan may be broken if the machine climbs a steep slope when going out of water. Be very careful.



WC-C200880

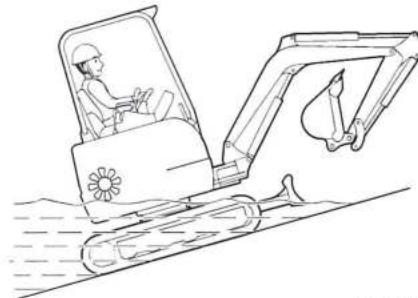

WC-C200140

Countermeasures if the machine is buried up to the super structure

If the machine is buried with water, soil or sand up to the super structure by mistake the swing bearing may wear abnormally. It is necessary to change grease in the turning structure or overhaul and repair the turning structure immediately. Stop operation and ask greasing, overhaul or repair works from the nearest service office.

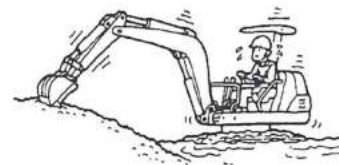

WC-C200890

OPERATION

PRECAUTION ON USE OF RUBBER SHOE

The rubber shoe may be damaged or worn faster depending on working conditions. Be sure to observe the prohibitions and instructions shown below.

Structure of Rubber Shoe

As shown in the figure to the right, the rubber shoe consists of steel cord to sustain tension, iron core to support it, and covering rubber to them.

NOTICE

If a crack reaches the steel cord, it may be rusted and cut off by moisture. When any crack is detected, immediate repair is essential. Please contact your local IHI distributor.

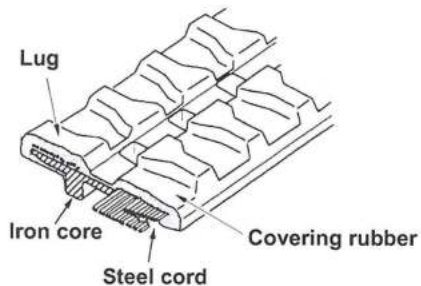

WC-C200900

Cautions while working and traveling

Do not travel or work on rocky site

This causes damage of the lug and breakage of the steel cord.



WC-C200910

Do not travel or work on riverbed

This causes damage and slipping off of the shoe.



WC-C200920

OPERATION

Do not travel or work on steel or scrap material

This causes damage of the lug and breakage of the steel cord.



WC-C200930

Do not travel on large step

While traveling up the large step, do not change the course.

Otherwise, the shoes may be slipped off.

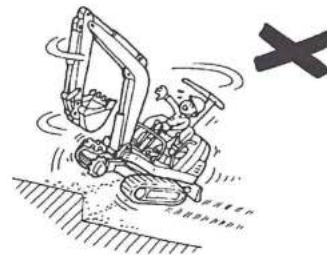

WC-C200940

Do not travel or work while spanning a ditch

This causes damage of the lug and breakage of the steel cord.

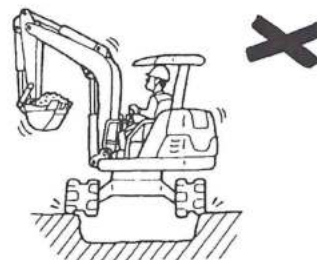

WC-C200950

Do not forcibly press soil while rubber shoes are slipping

Slipping of the rubber shoes promotes wear of the lugs.



WC-C201010

Do not travel over high heat locations

Do not travel over place subjected to high heat such as bonfires or steel plate under scorching heat.

This causes serious abrasion or damage and breakage of the lug.



WC-C201020

OPERATION

Do not hit the bucket

Be careful not to damage the rubber shoes with the bucket. Otherwise, the iron cores may be broken or the steel cords may be cut off.

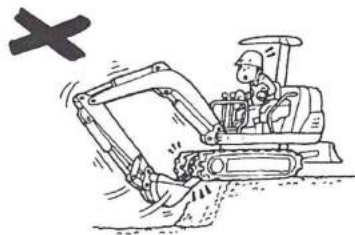

WC-C201030

Do not let oil, solvents and salt adhere to the rubber shoes

- If fuel, hydraulic oil and paint should adhere to the rubber shoes, wipe it away quickly.
- Wash away with water after working in locations with a large salt content. Salt can cause the iron core to rust or peel.

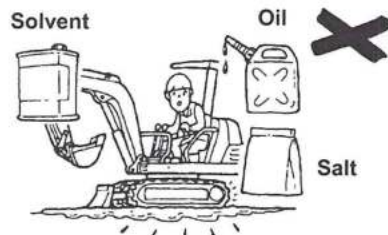

WC-C201050

Always keep proper tension on the shoe

If the rubber shoe is slack, it may damage the rubber shoe or cause them to come off the rollers.

This causes damage and slipping off of the shoe.

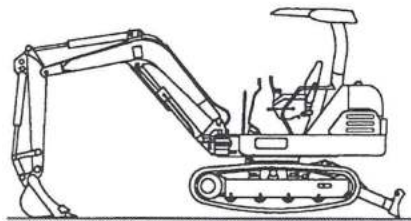

WC-C201060

PTO (POWER TAKE-OFF) FOR SPECIAL ATTACHMENT USE

NOTICE

- Select proper special attachments such as for example hydraulic breakers, iron forks, special hydraulic devices that can be hold by machinery.
- Some special accessories require reinforcement on arms. Get in touch with our dealer for further information about it.
- Read carefully manuals supplied by manufacturers and understand well the content before using special accessories.
- The assembly of a special attachment on machinery could affect many aspects, as for example the stability and transport dimensions. Be careful.

Pedal operation way or control lever may differ from a special attachment to another. Use special attachments properly, as described as follows.

Simple effect use (breaker hammer)

1. Connect supply hydraulic pipe to "A port" and the return hydraulic pipe to the "B port".
2. Turn the valve tap (3) with the key CH13 (included) and move the signal in the indicated position.

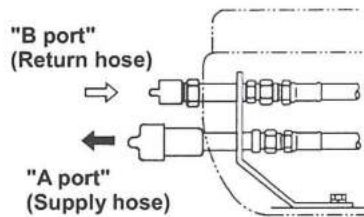

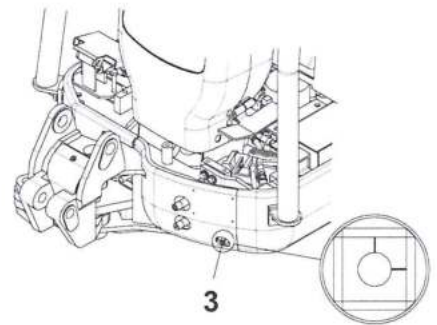

WB-C210480



Operation position simple effect

WARNING

If valve sign is as shown in  the return pressure becomes higher and the hammer does not work correctly.

Keep ALWAYS sign in position as shown .

3. Move the pedal (1) to working operation.
4. Step on front side of pedal to operate hammer. Step the pedal in neutral position to stop it.
5. Step the pedal in neutral position and close the cover to block it when we do not use the pedal.

NOTICE

- Make sure that the stop limit of the pedal is adjusted as shown in the figure, in the case of new assembly of the pedal or in case of passage from single to double-acting effect.
- Adjust height of stop limit (2) in order that the pedal (1) touches head of screw when is in neutral position and avoiding eventual movement if we push on rear side.

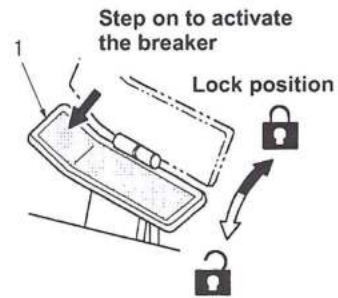

Working position WB-C210490

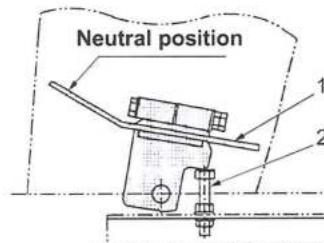

Contact with the pedal stopper at the pedal neutral position

WB-C210500

OPERATION

Double effect use (iron fork)

1. Connect hydraulic pipes to A and B ports.
2. Turn the valve tap (3) with the key CH13 (included) and move the signal in the indicated position.

WARNING

If valve sign is as shown in  the B port does not receive pressure.

Keep ALWAYS the signal in the position .

3. Step the pedal (1) to working operation.
4. Pushing on front side of pedal the supply is possible by means A port. Pushing on rear side of pedal the supply is by means B port.
5. Step the pedal (1) in neutral position and close the cover to block it when we do not use the pedal.

NOTICE

- Make sure that the stop limit of the pedal is adjusted as shown in the figure, in the case of new assembly of the pedal or in case of passage from single to double-acting effect.
- Adjust height of stop limit (2) in order that the pedal (1) touches head of screw when is in neutral position and avoiding eventual movement if we push on rear side.

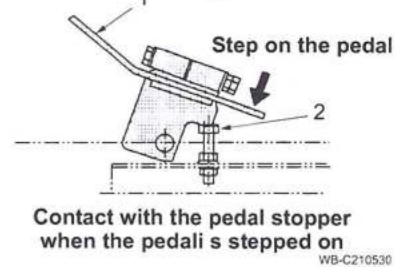
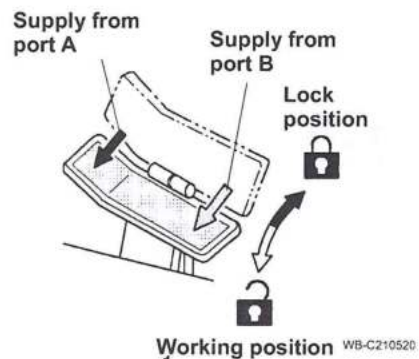
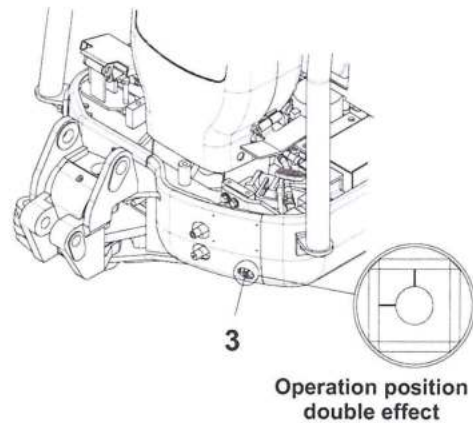
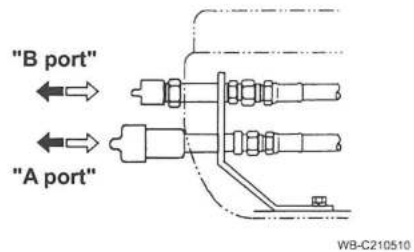

OPERATION

When using power port

1. Connect the supply hydraulic hose to the "A port" of the power port outlet and the return hydraulic hose to the "B port".
2. Set the lever (2) to the ON position, and compressed oil is supplied. Keep the lever (2) depressed and set the lock lever (1) to the lock position to supply compressed oil continuously.

Compressed oil is supplied through the power port now. Start and stop power port operation with the control valve of the hydraulic device (actuator).

NOTICE

The engine may fail to start if the lever (2) is set to the ON position. Be sure to set the lever to the OFF position when the power port is not used.

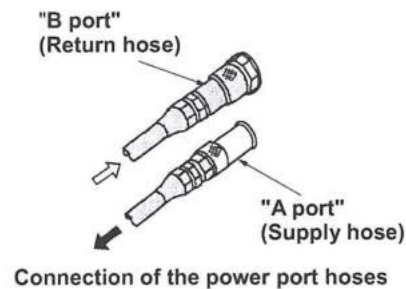

WB-C210540

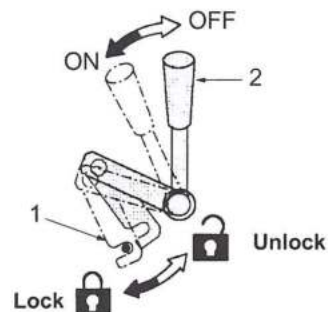

WB-C210550

OPERATION

TOWING

CAUTION

- It is very dangerous if the wire rope is disintegrated during towing. Do not stand between the towing machine and the towed machine.
- Use wire ropes and shackles for towing that are strong enough for the towing weight.
- The machine is provided with a pulling hook at the back of the lower frame to pull light objects. Never pull the machine itself or other heavy objects using this pulling hook.

Towing the machine or heavy objects

Apply a wire rope to the rear frame and pull the machine by another machine if it enters a muddy place and cannot escape from it by itself.

Never use the pulling hook for light objects to pull the machine itself.

1. Start the engine.
2. Pull the machine at the low speed. Do not use the travel speed change-over pedal.
3. Move the travel lever in the travel direction slowly when towing starts.

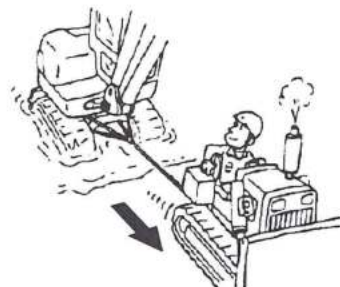

WC-C100290

NOTICE

Put a patch at the corner in contact with the wire rope to prevent the wire rope from being damaged.

NOTICE

When the engine is defective and does not start, the crawler shoes do not rotate and pulling is disabled.

Pulling light objects

Apply a wire rope to the pulling hook at the back of the lower frame using a shackle.

NOTICE

- The maximum pulling load should be 500 kg or less.
- Do not pull diagonally.



WC-C100310

OPERATION

TRANSPORT

Observe the loading and unloading methods and the anchoring method for transportation as well as the laws and regulations concerned when transporting the machine.

Loading and Unloading the Machine

! WARNING

- Carry out operation on a flat and firm ground.
- Carry out loading or unloading at the low speed without using the travel speed change-over pedal. Reduce the engine revolution.
- Be sure to use ramp boards or loading platform for loading and unloading. Never use the attachment to load or unload the machine. It is very dangerous.
- Use wide, long and thick enough ramp board that ensures safe loading and unloading.
- Remove mud from the crawlers and grease, oil, water and other adhered matters from the ramp boards to prevent slipping.
- Never change the direction on the ramp boards. It is very dangerous. Move down from the ramp boards once and change the direction.
- The center of gravity moves quickly at the border of the truck and the ramp boards. Travel the machine slowly.
- Warm up the machine sufficiently before loading or unloading it in cold seasons.

1. Apply the brake of the truck securely. Apply blocks to the tires to fix the tires.
2. Adjust the center line of the machine to the center line of the truck. Adjust the ramps boards to the crawler width.
3. The angle of the ramp boards should be 15° or less.
4. Load the machine from the front if it has an attachment. Load it from the rear if no attachment is mounted.
5. Adjust the machine to the ramp board direction, raise the blade and travel the machine slowly with care not to hit the attachment against the truck.
6. Load the machine properly in the designated position on the truck.

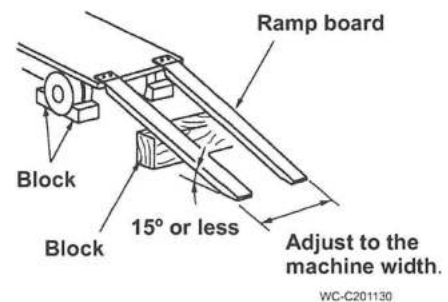

OPERATION

Fixation at Transport

WARNING

If the machine falls down during transportation, it can cause personal injury or death.
Fix the machine firmly on the platform of the truck with wheel blocks and wire ropes.

1. Lower the blade onto the platform of the truck.
2. Fold the arm and bucket fully. Lower the attachment onto a wooden block, etc.
3. Stop the engine and pull out the key from the engine key switch.
4. Apply stopper blocks to the front and rear positions of the crawlers.
5. Apply wires to the crawler frame and bucket and fasten them to the platform of the truck.

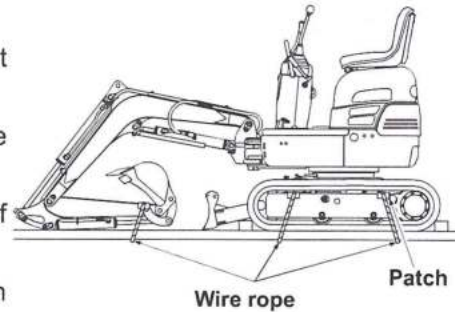

WC-C210560

NOTICE

If wire ropes are applied to the rubber shoes directly when fixing the machine, the rubber shoes may be damaged. Put patches on the front and rear positions of the crawler frame and fix with the wire ropes.

OPERATION

LIFTING THE MACHINE

CAUTION

Lifting the machine incorrectly can cause damage, injury and death.

- Use adequate steel ropes and equipment for lifting.
- Use lifting equipment able to support the weight of the machine.
- NEVER LIFT the machine with anyone on-board.
- Use signs and other notices to mark off the loading area.
- Always use ropes and other equipment rated to lift at least **4 ton** loads.

1. Set the blade at the rear position.
2. Raise the blade to the highest position.
3. Raise the boom to the highest position and fold the arm and bucket fully.
4. Make the boom straight if it has swung to the right or left.
5. Fasten wire ropes to the lifting holes at the back of the boom using the shackle.
6. Stop the engine and get off the machine.
7. Fasten the wire ropes to the lifting holes at both ends of the blade using shackles.
8. Lift the machine slowly until it is lifted slightly apart from the ground, stop lifting once, check the machine balance, and lift the machine to the intended height.

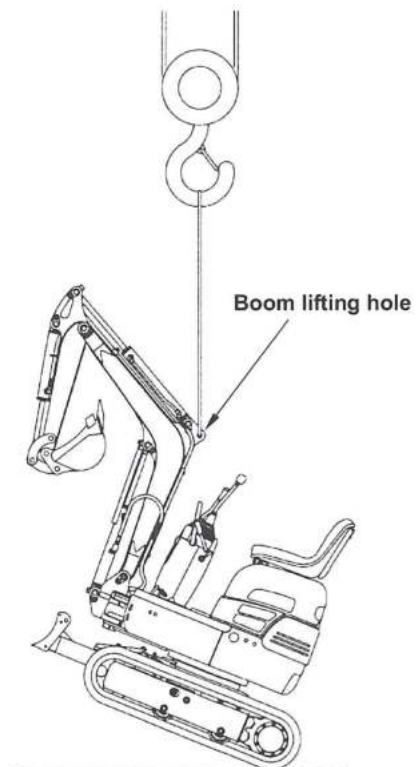

WB-C210570

OPERATION

This page is intentionally left blank

MAINTENANCE

Proper maintenance is needed to maintain the machine performances for long and prevent damages and troubles in advance.

This section describes the proper maintenance procedures of this machine. Carry out maintenance safely and properly in accordance with the instructions described below.

MAINTENANCE

PERIODIC REPLACEMENT OF THE IMPORTANT PARTS

Replace the following parts, which are related to the safety and a fire, periodically.

These parts are subject to aged deterioration and wear, and it is hard to judge the service life by means of appearance inspection. Replace them periodically even though they have no apparent defects, in particular.

Type	Parts to be replaced periodically	Qty	Replacement interval
Fuel hose	Fuel tank - Water separator	1	Every 2 years
	Water separator - Fuel pump	1	
	Fuel pump - Fuel filter	1	
	Fuel filter - Inlet of injection nozzle	1	
	Return of injection nozzle - Fuel filter	1	
	Fuel filter - Fuel tank	1	
Coolant hose	Radiator hose (upper)	1	Every 2 years
	Radiator hose (lower)	1	
	Radiator - Sub tank	1	
Hydraulic hose	Hydraulic pump - Control valve	2	Every 2 years
	C/V - Boom cylinder	4	
	C/V - Arm cylinder	4	
	C/V - Bucket cylinder	4	
	C/V - Boom swing cylinder	4	
	C/V - Blade cylinder	4	
	C/V - Swing motor	2	
	C/V - Travel motor	8	

Repair or replace these parts immediately if some abnormalities or defects are found in them even before the replacement interval.

Also check the fuel hoses, cooling water hoses and hydraulic hoses in daily check, monthly check and yearly check.

MAINTENANCE

MAINTENANCE INTERVALS

Periodic maintenance is most important to operate the machine safely and demonstrate its performances fully.

Take special care when using the machine under severe condition.

Δ: Check. ○: Replace.

	Maintenance point	Maintenance work	Maintenance interval								
			Daily	50h	150h	250h	500h	1000h	1500h	2000h	Irregular
Greasing	Attachment	Grease	See the LUBRICATE THE GREASE section for details.								
	Boom swing										
	Blade										
	Swing bearing										
	Ring gear										
Bucket	Bucket tooth	Replace		Δ							○
	Bucket	Replace		Δ							○
Crawler	Rubber shoe	Check wear & deterioration	Δ								○
	Shoe tension	Check and adjust									Δ
Reduction gear	Travel reduction gear	Check oil leak	Δ								
		Check oil qty & refill					Δ				
		Change oil			○ First time			○			

MAINTENANCE

	Maintenance point	Maintenance work	Maintenance interval									
			Daily	50h	150h	250h	500h	1000h	1500h	2000h	Irregular	
Hydraulic system	Hydraulic oil tank	Check oil qty & refill	Δ									
		Drain water		Δ								
		Change hydraulic oil. Clean the tank						○				
	Suction strainer	Clean						Δ				
	Return filter	Replace cartridge		○ First time				○				
	Hydraulic devices	Check oil leak	Δ									
	Hydraulic equipment	Check oil leak	Δ									
Lubrication system	Engine oil	Check oil qty & refill	Δ									
		Change		○ First time		○						
	Oil filter	Replace		○ First time		○						
Fuel system	Fuel tank	Check oil qty & refill	Δ									
		Drain water				Δ						
	Water separator	Check	Δ									
		Clean Replace element					Δ					○
	Fuel filter	Replace					○					
	Fuel hose	Change								○		

MAINTENANCE

	Maintenance point	Maintenance work	Maintenance interval										
			Daily	50h	150h	250h	500h	1000h	1500h	2000h	Irregular		
Cooling system	Sub tank	Check coolant qty & refill	Δ										
	Radiator	Clean						Δ					
		Change coolant						○					
	Radiator fins Oil cooler fins	Check & clean				Δ							
	Fan belt	Adjust tension			Δ First time		Δ						
		Check cracks	Δ										○
Intake system	Air cleaner	Check dust indicator	Δ										
		Check element & clean				Δ							
		Replace element					○						
Engine	Governor lever	Check & adjust	Δ			Δ							
	Intake valve & exhaust valve head	Adjust clearance						●					
	Fuel injection system	Check, clean & check functioning							●				
	Crank case breather	Check							●				
	Coolant path	Clean								●			
	Intake valve & exhaust valve seat	Lap								●			
Electric system	Fuse	Replace										○	
	Fusible link	Replace										○	
	Battery	Check battery liquid qty & refill		Δ									
		Clean terminals							Δ				
Bolt tightening		Retightening										Δ	

●: Contact our dealer.

MAINTENANCE

RECOMMENDED LUBRICATION TABLE

Lubrication points	Oil type	Grade	Temp. & application (°C)								Qty required	
			-30	-20	-10	0	10	20	30	40		
Engine oil pan	Engine oil	API-CD	*	SAE10W-30								H: 1.8 L L: 1.2 L
				SAE15W-40								
Hydraulic oil tank	Hydraulic oil	Abrasion-resistant	*	ISO-VG46								System: 16 L Tank level: 8.2 L
				ISO-VG32								
Travel reduction gear	Engine oil	API-CD		SAE30								0.33 L
Fuel tank	Diesel fuel	-										8.8 L
Cooling system	Coolant	-	Long-life coolant (LLC) added								Total qty: 2.2 L For engine only: 0.6 L	
Greasing	Grease	-	Lithium grease EP2								Proper qty	

- The oil with the * marks is used for the machine before shipment.

MAINTENANCE

LUBRICATE THE GREASE

Attachment

1. Lower the attachment in the greasing posture onto the ground and stop the engine.
2. Fill grease using a grease gun through all grease nipples.
3. Wipe off old grease that oozes out of the grease nipples completely after greasing.

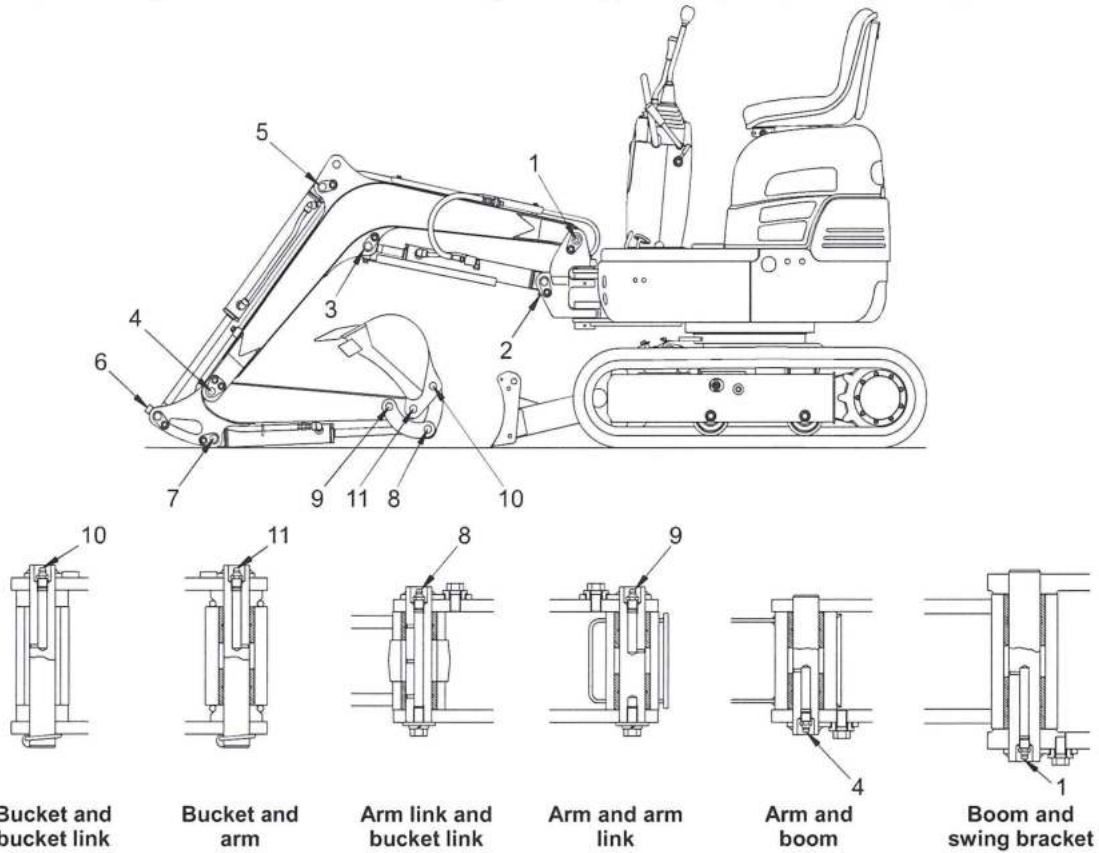

WB-C310010

No.	Name	Qty	Greasing interval						
			Daily	50h	100h	250h	500h	1000h	2000h
1	Boom foot pin	1		○					
2	Boom cylinder foot pin	1		○					
3	Boom cylinder rod pin	1		○					
4	Arm foot pin	1		○					
5	Arm cylinder foot pin	1		○					
6	Arm cylinder rod pin	1		○					
7	Bucket cylinder foot pin	1		○					
8	Bucket cylinder rod pin	1		○					
9	Arm link pin	1		○					
10	Bucket link pin	1		○					
11	Bucket pin	1		○					

MAINTENANCE

Boom Swing

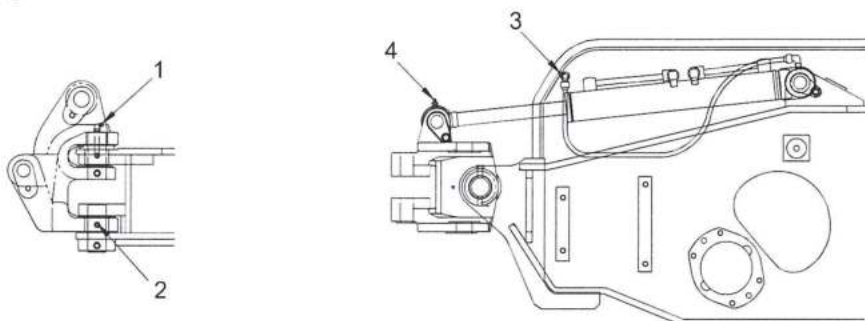

WB-C310020

No.	Name	Qty	Greasing interval						
			Daily	50h	100h	250h	500h	1000h	2000h
1	Boom swing vertical shaft (upper)	1		○					
2	Boom swing vertical shaft (lower)	1		○					
3	Swing cylinder foot pin	1		○					
4	Swing cylinder rod pin	1		○					

Blade

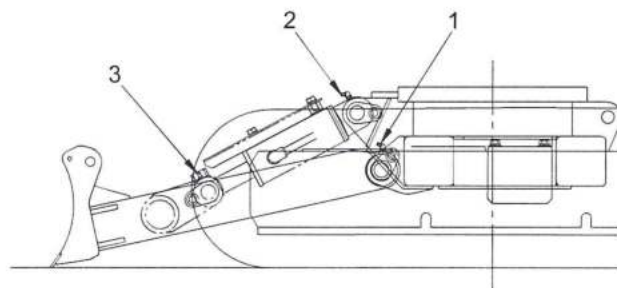

WB-C310030

No.	Name	Qty	Greasing interval						
			Daily	50h	100h	250h	500h	1000h	2000h
1	Blade foot pin	2		○					
2	Blade cylinder rod pin	1		○					
3	Blade cylinder foot pin	1		○					

NOTICE

- Lubricate the machine everyday until its operation time reaches 100 hours, if it is a new machine.
- Carry out greasing, regardless of the greasing interval, if abnormal noises are generated from a greasing point.
- Be sure to grease the pins around the bucket before starting in-water digging.

MAINTENANCE

Swing Bearing

1. Lower the bucket onto the ground and stop the engine.
2. Supply grease with a grease gun by 3 to 5 strokes through the grease nipple (1) for the turning bearing of the concentrated piping on the front of the machine.
3. Fill grease every time the upper structure is swung by approximately 90 degrees until it swings by 360 degrees.

Ring Gear

1. Lower the bucket onto the ground and stop the engine.
2. Fill three to five strokes of grease using a grease gun into the grease nipple (2) on the front of the machine.
3. Fill grease every time the upper structure is swung by approximately 90 degrees until it swings by 360 degrees.

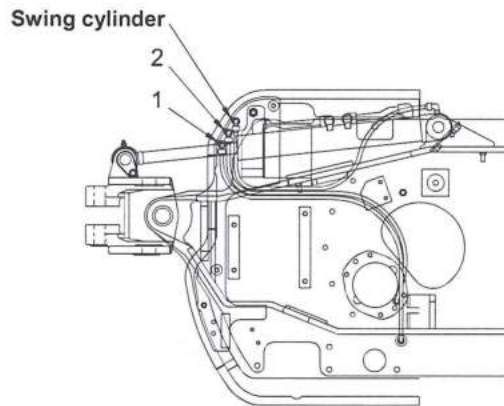

WB-C310040

No.	Name	Qty	Greasing interval						
			Daily	50h	100h	250h	500h	1000h	2000h
1	Swing bearing	1		○					
2	Ring gear	1		○					

! WARNING

If you carry out greasing while the machine is swinging, you may be caught by it. Do not swing the machine when greasing.

NOTICE

If greasing is carried out in the same position, grease is not spread all over the swing bearing. Be sure to swing the machine by approximately 90 degrees and grease the bearing at different points.

MAINTENANCE OF BUCKET

Change the Bucket

⚠ CAUTION

- When the pin is driven with a hammer, fragments may scatter, resulting in injury. Put on protective goggles, protective cap and protective gloves in work.
- Never insert your finger into the pin holes when adjusting the pin holes.

Remove the bucket

1. Place the back of the bucket completely on the ground.
2. Remove the ring pin from the portion (A).
Remove the arm point pin.
3. Remove the ring pin from the portion (B).
Remove the bucket link pin.
4. Raise the arm slowly.
Then remove the arm and the bucket.

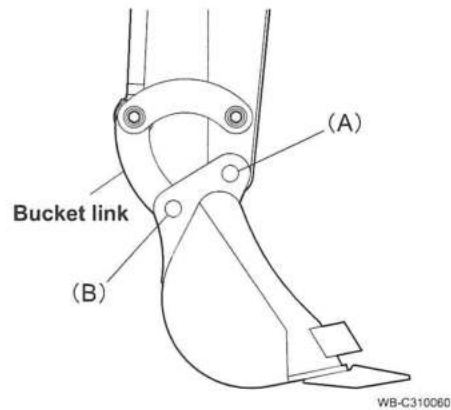

Install the bucket

1. Clean the pin holes in the arm and bucket link and the removed pins. Apply grease to the holes and pins.
2. Replace the O-rings if they are damaged or worn. Attach new O-rings to the bosses of the bucket temporarily.
3. Lower the arm slowly, fit the pin holes in the arm and bucket, and drive the arm point pin.
4. Attach the ring pin to lock the arm point pin.
5. Raise the boom to move the bucket apart from the ground and make it free.
6. Extend or contract the bucket cylinder to adjust the pin hole in the bucket link and bucket. Drive the bucket link pin into the holes.
7. Attach the ring pin to lock the bucket link pin.
8. Move the O-rings to the proper grooves.
9. Grease the arm point pin and bucket link pin.

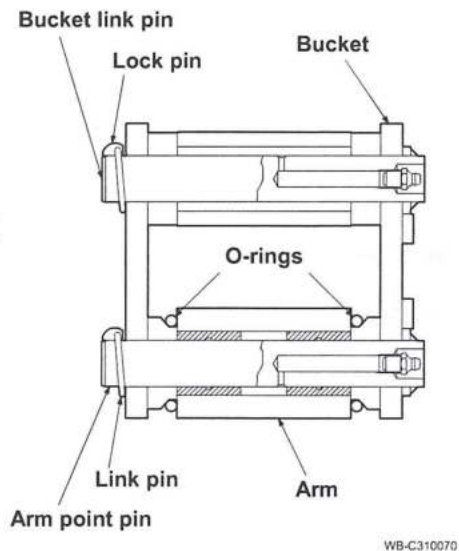

CRAWLER SHOE

Rubber Shoe Maintenance

Rubber shoe should be repaired or exchanged if goes into any of the conditions described below.

If it is necessary to repair or replace it, contact your IHI dealer.

Height of Lug

The rubber shoe can be used even if it is worn, however, if it is excessively worn, the rubber shoe is likely to be slippery and more travel force is required. If the remaining lug is less than 5 mm high, exchange it with brand-new one.

Exposure of Steel Cord

If steel cord is exposed because of weary rubber or damage, exchange it with brand-new one.

Cutting of Steel Cord

When cutting of steel cord is detected, exchange it immediately. If you leave it as it is, the rubber shoes can be cut off without expectation, which causes a serious accident.

Crack of Covering Rubber

If a crack is 30 mm or more long and 8 mm or more deep, repair the covering rubber immediately. If steel cord appears even if a crack is small, repair it immediately. Otherwise, water may come into a crack, which rusts steel cords and cuts off the rubber shoe.

Dislocation of the iron core

Exchange the rubber shoe with a new one if one or more iron cores are dislocated from it.

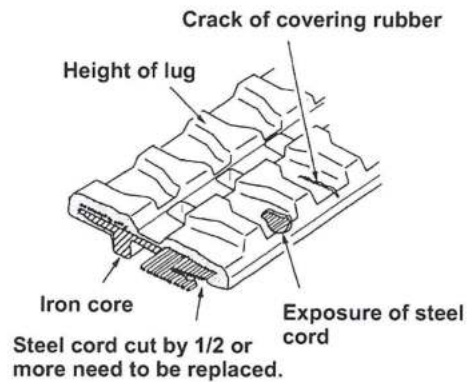

Damages of rubber shoe

WC-C300630

MAINTENANCE

Inspection of crawler shoe

The conditions of wear and sag of the crawler shoes differ with the conditions of the work sites. If the slack crawler shoes are used, they may be slipped off. Inspect and adjust their tension as the necessity requires.

Inspection

1. Raise the machine using the attachment and blade until the crawler shoes become apart from the ground. Support the crawler frame securely with blocks, etc.
2. Measure the clearance between the tread of the lower roller near the center and the tread of the crawler shoe.
The tension is proper if the clearance is as shown below.

10 to 20 mm (Rubber shoe)

WARNING

The machine needs to be raised to inspect the shoe tension. If the machine drops by mistake during inspection, a serious injury may result. Be very careful when the machine is raised.

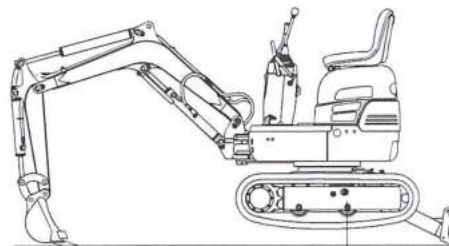

Jack up the machine until the shoes separate from the ground.

Lower roller

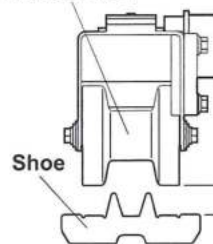

Shoe

Amount of sag

WB-C310080

MAINTENANCE

Adjustment of Crawler Shoe

Tension the crawler shoe

1. Fill grease through the grease nipple (2) of the check valve (1) until the crawler shoe is tensioned properly.
2. Rotate the crawler forward and backward and check tension. Re-adjust it if necessary.

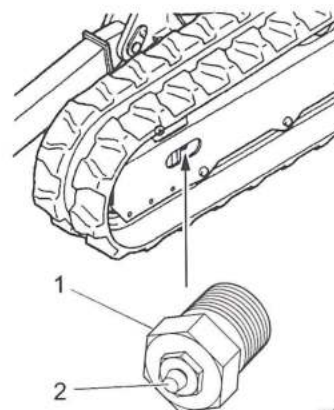

NOTICE

- Adjust the right and left crawler shoes evenly.
- If the shoes are not tensioned properly, the cylinders may be defective. Ask IHI's service dealer for repair services.

Loosen the crawler shoe

1. Remove dirt and soil from around the front idlers.
2. Loosen the check valve until grease is discharged (by a maximum of one turn) little by little. Do not loosen it when grease is discharged.
3. Rotate the crawler shoe forward and backward slightly if grease is hardly discharged.
4. Tighten the check valve when the crawler shoes are tensioned properly.

Tightening torque: 59 to 69 N·m (6 to 7 kgf·m)

NOTICE

Be careful not to over-tighten the check valve.

5. Rotate the crawler shoe forward and backward and check tension. Re-adjust it if necessary.

⚠ WARNING

- When the crawler shoe is tensioned intensely, the internal pressure in the grease cylinder is very high. Grease may spout out or the check valve may spring out, causing a serious accident.
- To relief the pressure, loosen the check valve gradually. Do not loosen it when grease is discharged. (It should be loosened by a maximum of one turn.)
- Grease may spout out at high pressure. Never loosen the grease nipple.
- Do not bring your face or hand close to the check valve during adjustment.

TRAVEL REDUCTION GEAR

Check Oil Level and Refilling

1. Stop the engine so that the drain port is located at the lower position.
2. Place the container under the travel reduction gear.
3. Remove the oil filler/level plug. The oil level is proper if the oil surface reaches the bottom of the plug hole.
4. Pour oil through the oil filler/level port until the oil surface reaches the bottom of the level port, if oil is insufficient.
5. Clean the filler/level plug and attach them.

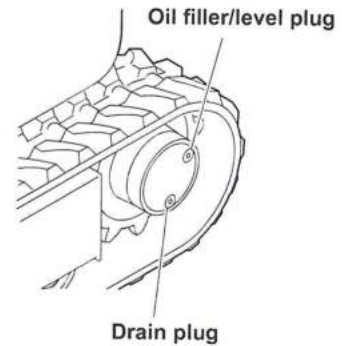

Change Oil

1. Locate the drain port to the lower position and stop the engine.
2. Place the container under the drain port.
3. Remove the oil filler/level plug.
4. Remove the drain plug to discharge oil.
5. Discharge oil completely. Then, clean the drain plug and attach it.
6. Fill oil until it flows out from the filler/level port.
7. Clean both plugs and attach them.

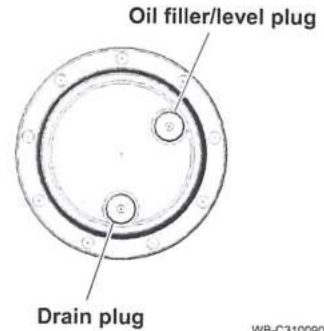

WB-C310090

Specified oil	Qty
Engine oil API CD, SAE30	0.33 L

⚠ CAUTION

The gear case and oil are hot immediately after stopping the engine. Wait until the temperature lowers.

MAINTENANCE

HYDRAULIC SYSTEM

Place the machine in a horizontal place, bring the blade in contact with the ground, retract the arm cylinder and bucket cylinder fully, and move down the boom to lower the bucket onto the ground when executing inspection and/or maintenance of the hydraulic system.

CAUTION

- Oil is hot immediately after stopping the engine. Wait until the temperature lowers and start operation then.
- Hydraulic oil is compressed. If the filter cartridge is taken out in such a condition, oil spurts out, resulting in a dangerous accident. Be sure to stop the engine and lower the internal pressure.

Hydraulic Oil Level and Refilling

1. Stop the engine.
2. Check the oil level gauge (1). If the oil level is between H and L, it is proper. The oil level differs with the oil temperature. The following shows the standard.

- Near the L level before starting operation
(Oil temperature: 10°C to 30°C)
- Near the H level during operation
(Oil temperature: 50°C to 80°C)

3. If the oil level is below the L level, refill hydraulic oil through the filler port (2).

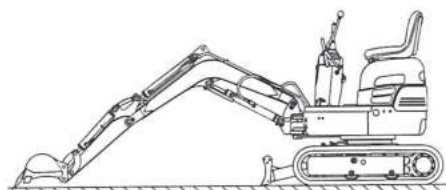

Posture of checking hydraulic oil level

WB-C310100

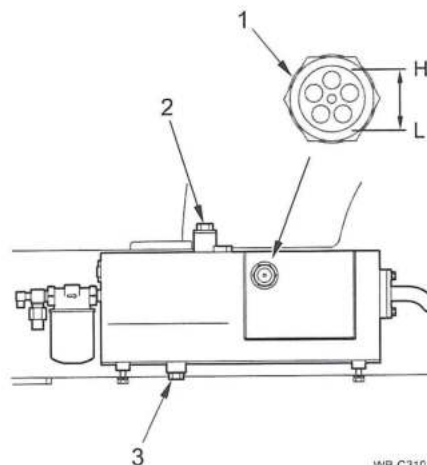

WB-C310120

NOTICE

- Do not operate the machine if the oil level is below the "L" level.
- Loosen the drain plug and discharge excess oil if oil is filled over the "H" level.

Drain the Hydraulic Oil Tank

1. Loosen the drain plug (3) under the hydraulic oil tank to discharge water and sediment into the container.
2. Tighten the drain plug when clean hydraulic oil is only discharged.
3. Check the hydraulic oil level and refill oil if insufficient.

MAINTENANCE

Replace Return Filter Cartridge

1. Stop the engine.
2. Loosen the oil filler plug (1) of the hydraulic oil tank to lower the internal pressure of the tank.
3. Turn the filter cartridge (2) counterclockwise with the filter wrench.
4. Apply hydraulic oil thinly to the gasket (3) of a new cartridge and tighten it with the filter wrench. When the gasket is crushed and the top surface of the cartridge is brought into contact with the head (4), it is the limit of tightening.
5. Start the engine and make sure that no oil leaks from the gasket of the cartridge.
6. Bring the machine into the posture of checking the oil level and check the level.
The oil level is proper if it is between H and L of the level gauge (5). Refill hydraulic oil if insufficient.
7. Extend all cylinders fully, attach the oil filler plug, and pressurize the tank.

NOTICE

When the breaker work is done, hydraulic oil is deteriorated more than normal digging works. Replace the filter cartridge every 100 hours.

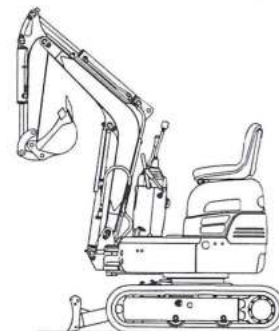
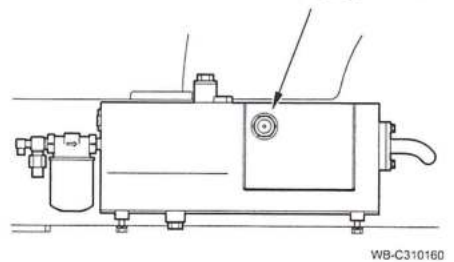
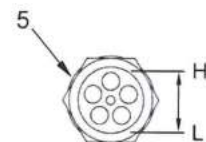
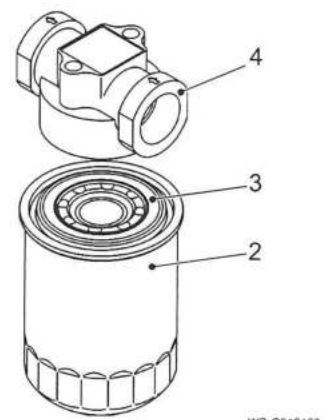
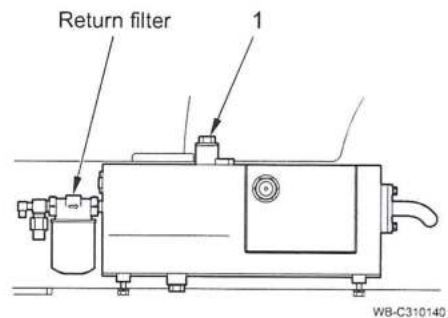

Posture of pressurizing hydraulic oil tank

MAINTENANCE

Change the Hydraulic Oil and Clean the Strainer

1. Swing the upper structure until the drain plug (1) of the hydraulic oil tank is in the center of the right and left crawlers.

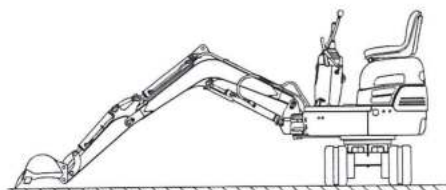

Posture of discharging hydraulic oil

WB-C310180

2. Lower the boom to lower the bucket onto the ground.

3. Stop the engine.

4. Remove the oil filler plug (2) of the hydraulic oil tank to discharge air from the tank.

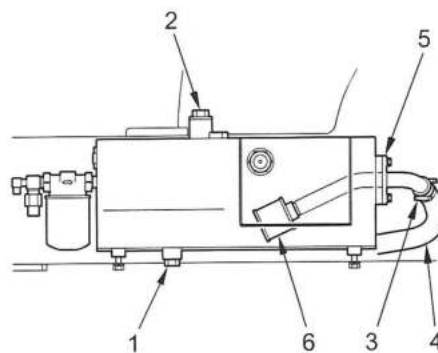

WB-C310190

5. Place the container under the drain plug. Remove the drain plug to discharge oil. Tighten the drain plug after discharging oil.

6. Loosen the hose clamp (3), disconnect the hose (4), and remove the strainer cover (5).

7. Clean the strainer (6) and attach it.

8. Attach the strainer cover, hose, and hose clamp.

9. Refill the tank with hydraulic oil through the oil filler port up to the specified level.

Make sure that the oil level is between H and L of the level gauge (7).

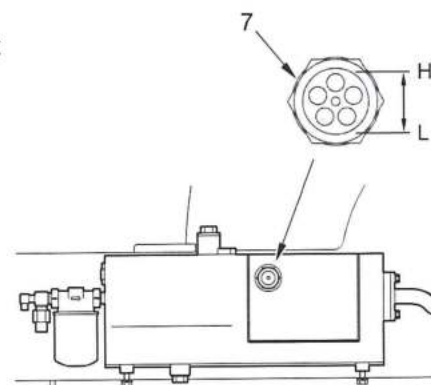

WB-C310200

10. Idle the engine for approximately two to three minutes at low speed. Bring the machine into the level checking posture and check the oil level. Refill hydraulic oil if insufficient.

MAINTENANCE

11. Pressurize the hydraulic oil tank.
Extend all cylinders fully.
Remove the oil filler plug to fill the tank with air.
Attach the plug then.

NOTICE

The service life of the hydraulic pump becomes shorter and serious damages may result, if the tank is not pressurized.

NOTICE

Breaker work is done in severer conditions than normal digging works and hydraulic oil is deteriorated earlier. If the machine is used with deteriorated hydraulic oil, the hydraulic devices and the whole hydraulic circuit may become defective. Change hydraulic oil and clean the strainer every 500 hours.

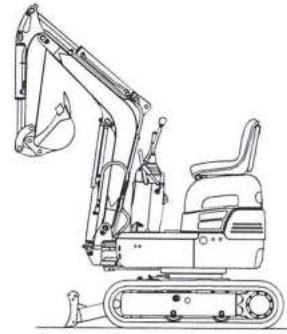

Posture of pressurizing hydraulic oil tank

WB-C310170

MAINTENANCE

Hydraulic System Diagram

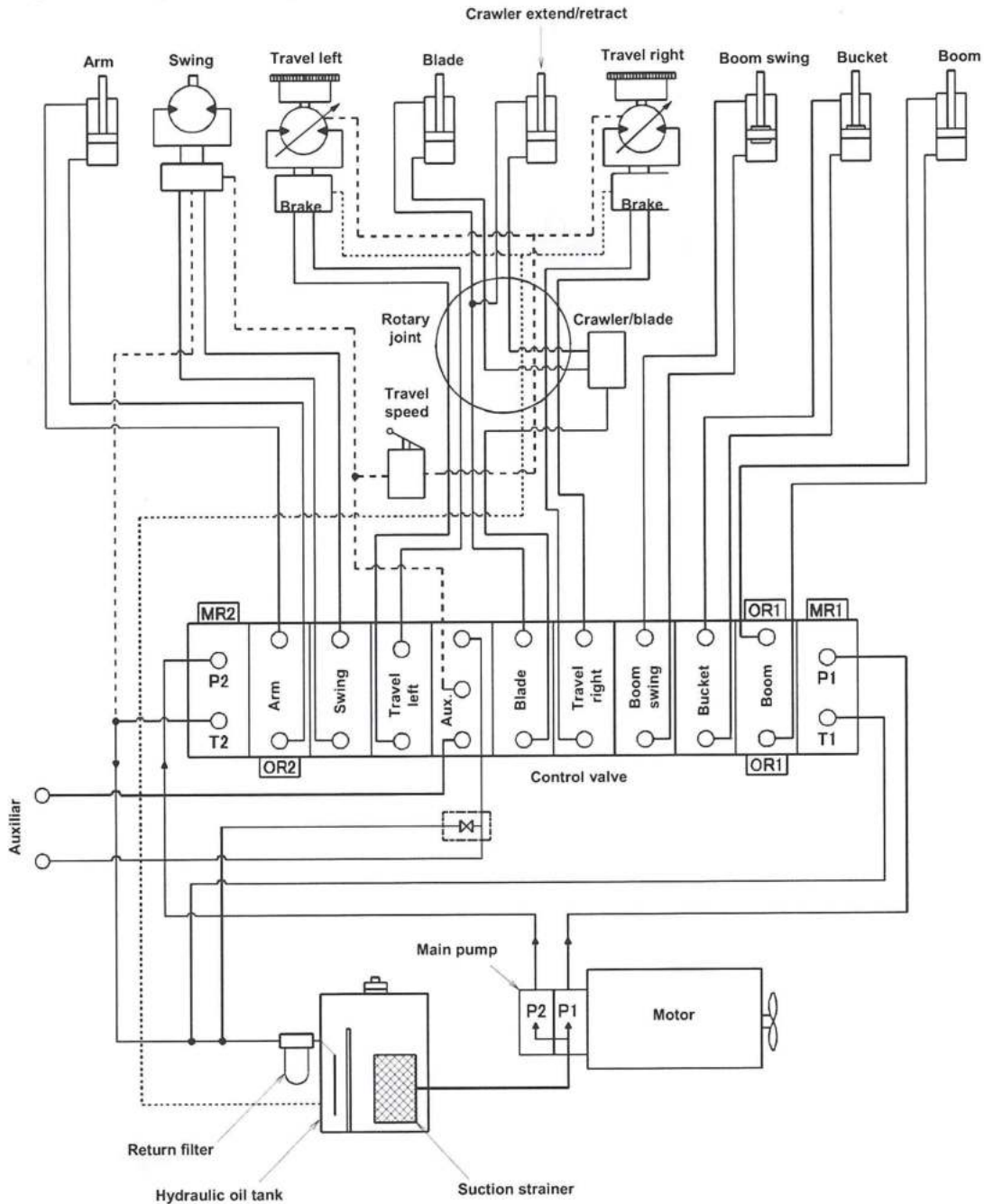

Relief valve set pressure

Code	Item	Pressure		
		MPa	kgf/cm ²	psi
MR1	Main relief valve P1 Pump	16.2	165	2347
MR2	Main relief valve P2 Pump	16.2	165	2347
OR1	Overload relief valve (Boom)	18.6	190	2702
OR2	Overload relief valve (Arm)	18.6	190	2702
SWR	Swing relief valve	6.9	70	996

Pump flow rate (Max.):
 P1: 11.1 L/min
 P2: 11.1 L/min

ENGINE OIL

Place the machine in a horizontal place, bring the blade in contact with the ground, retract the arm cylinder and bucket cylinder fully, and move down the boom to lower the bucket onto the ground when executing inspection and/or maintenance of the lubrication system.

CAUTION

- Oil is hot immediately after stopping the engine. You may get burnt if you touch oil. Start work after oil has cooled down.
- Wipe off spilt oil completely. If it is left as is, it may cause a fire.

Check the Engine Oil Level and Refill

1. Stop the engine.
2. Pull out the oil level gauge, clean it with cloth, insert it fully again, and pull it out slowly.
3. The oil level is proper if it is between the marks of the upper and lower limits.
Refill the engine with engine oil through the oil filler port if the oil level is below the lower limit.
4. Discharge excess oil through the drain port if the oil level is over the upper limit. Check the oil level again.

NOTICE

- Make the machine horizontal before checking the oil level.
- Check the oil level 10 minutes or more after stopping the engine, if the engine has started.
- Do not start the engine if the oil level exceeds the upper limit or below the lower limit.

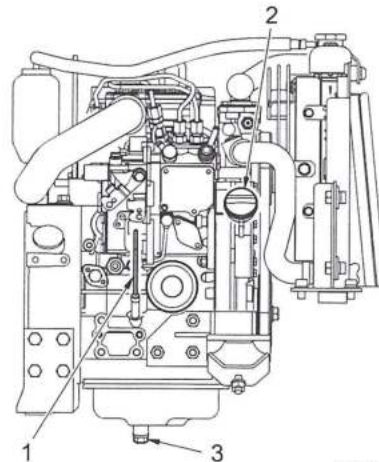

WB-C310220



WC-C300320

MAINTENANCE

Replace the Engine Oil and Engine Oil Filter

1. Stop the engine.
2. Place the container just under the drain port of the engine.
3. Clean the oil filler cap (2) and around it in order not to let in foreign matters. Remove the oil filler cap.
4. Remove the drain plug (3) slowly so that oil will not splash on you. Discharge oil.
5. Check waste oil. If you find a lot of metallic powder, foreign matters, etc., contact our service office.
6. Turn the filter (4) counterclockwise to detach it using the filter wrench.
7. Clean dust and foreign matters from the filter mounting surface.
8. Apply engine oil thinly onto the gasket of a new filter.
9. Turn the filter to the right to mount it. Tighten it further by approximately 3/4 turn with the filter wrench after the gasket contacts with the seal surface.
10. Attach the drain plug.
11. Fill the engine with engine oil until the oil level becomes between the upper limit and lower limit of the level gauge (1).
12. Idle the engine for several minutes, stop the engine, and check the level of engine oil 10 to 20 minutes later. Refill the engine with engine oil up to the specified level if the oil level is low.

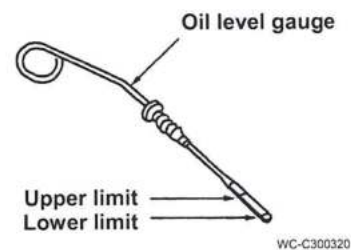
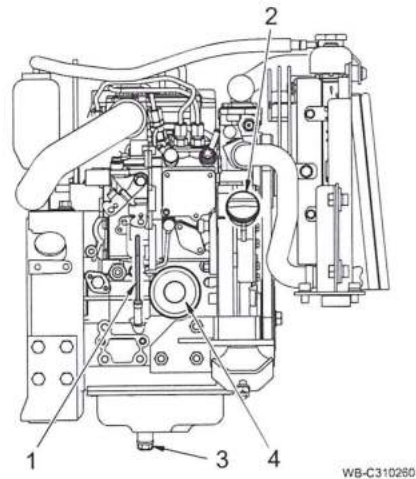

FUEL SYSTEM

Check Fuel Quantity and Refilling

1. Turn the engine key switch key to the ON position and check the quantity of remaining fuel on the fuel gauge.

Fuel tank capacity: 8.8 L

2. Refill the tank with fuel through the filler port (1) if remaining fuel is insufficient.
Clean the strainer (2) of the filler port (1) if it is dirty.
3. Tighten the cap after refilling. Lock it with the engine key.

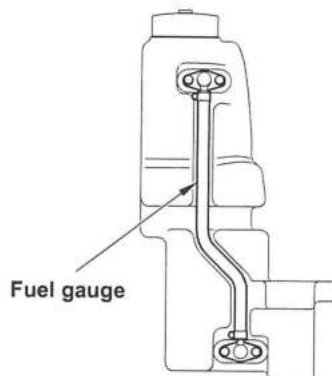

WB-C310270

⚠ CAUTION

- If fuel overflows or spills, it may cause a fire. Wipe off spilt fuel completely.
- If the strainer is dismantled and fuel is refilled, the engine may become defective. Do not dismantle it.
- Do not bring fire close to the engine.
- If any other fuel than light oil, bad influences are caused upon the engine, which may be incapable of demonstrating its functions and performances sufficiently. In addition, using such fuel may cause engine failures or accidents. Never use any other fuel than light oil.
Defects caused by using any other fuel than light oil is exempted from warranty.

Discharging Water from Fuel Tank

1. Open the drain plug at the bottom of the fuel tank to discharge water and sediment before starting work.
2. Close the drain plug when clean fuel comes out.

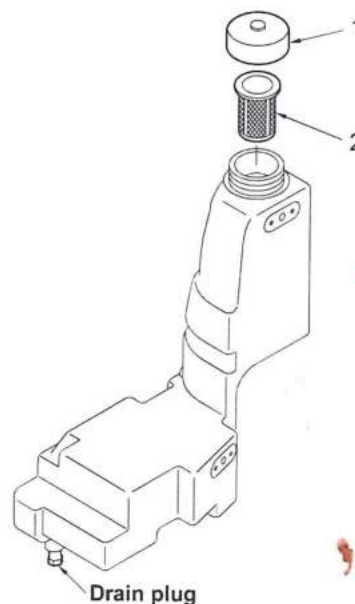

WB-C310280

MAINTENANCE

Check and Clean Water Separator and Replace Element

If the float (1) of the water separator is floating, water reaches the bottom of the float.

Discharge water if the float reaches the element (2).

1. Stop the engine.
2. Close the fuel cock (3).
3. Turn the retainer ring (4) counterclockwise and remove the cup (5).
4. Take out the float and spring (6) from inside of the cup.
5. Discharge water and sediment from inside of the cup into the container.
6. Put the float and spring in the cup.
7. Turn the retainer ring clockwise and attach the cup. Tighten the ring by hand.
8. Open the fuel cock as before.
9. Discharge air from the water separator.
10. Make sure that no fuel leaks.

Cleaning and Replacing

1. Stop the engine.
2. Close the fuel cock.
3. Turn the retainer ring counterclockwise and detach the cup.
4. Take out the float and spring from inside of the cup.
5. Discharge water and sediment from inside of the cup into the container.
6. Clean the element and inside of the cup completely with fresh fuel. Replace the element if it is flawed or damaged.
7. Attach the element and O-ring to the body.
8. Put the float and spring in the cup.
9. Turn the retainer ring clockwise and attach the cup. Tighten the ring by hand.
10. Open the fuel cock as before.
11. Discharge air from the water separator.
12. Make sure that no fuel leaks.

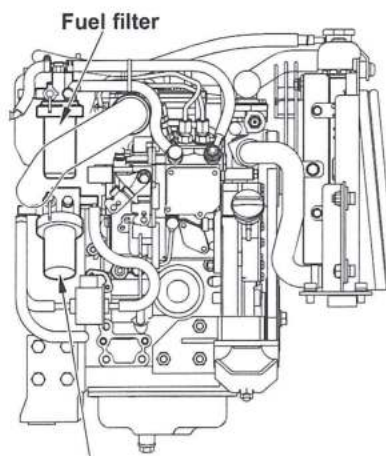

WB-C310290

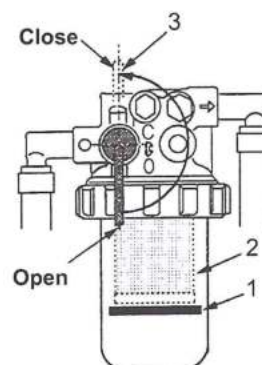

WC-C300380

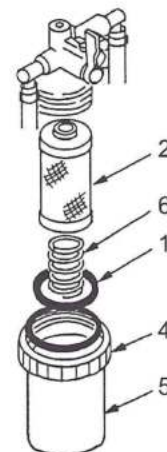

WC-C300381

CAUTION

- Fuel is hot immediately after stopping the engine. Carry out the work after the fuel temperature has become lower.
- Do not bring fire close to the engine.
- Wipe off spilt fuel completely. If it is left as is, it may cause a fire.

MAINTENANCE

Replace Filter Element

1. Stop the engine.
2. Turn the fuel cock (1) to the "Close" position to cut off fuel.
Fuel may flow out if the cup (3) is removed without turning the fuel cock to the "Close" position.
3. Turn the retainer ring (2) counterclockwise and remove the cup. Pull down the element (4) to detach it.
4. Clean the inside of the cup.
5. Attach a new element and O-ring (5) to the body. Replace the O-ring if it is damaged.
6. Turn the retainer ring clockwise and attach the cup. Tighten the ring by hand.
7. Open the fuel cock as before.
8. Discharge air when the fuel filter is replaced.
9. Make sure that no fuel leaks.

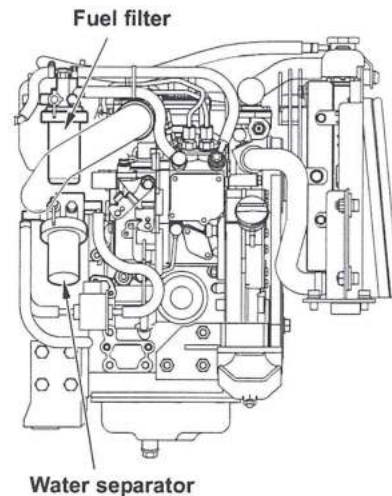

WB-C310290

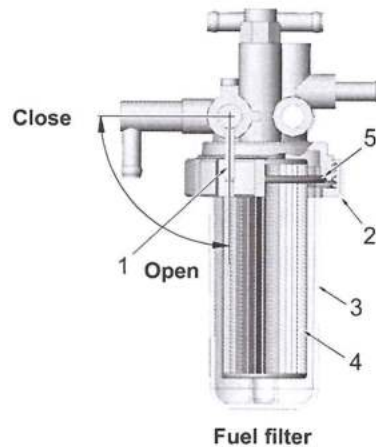

WC-C300400

How To Discharge Air

Discharge air after maintenance of the fuel filter or water separator is carried out or the fuel tank is emptied.

1. Fill the fuel tank full with fuel.
2. Turn the engine key switch to the ON position and keep it at that position for approximately 20 seconds.
3. The automatic air discharging device discharges air automatically. The engine can be started.

CAUTION

- Fuel is hot immediately after stopping the engine. Carry out the work after the fuel temperature has become lower.
- Do not bring fire close to the engine.
- Wipe off spilt fuel completely. If it is left as is, it may cause a fire.

COOLING SYSTEM

Check the Coolant Level and Refill

! CAUTION

Do not open the radiator cap normally. Check coolant in the subtank when the engine is cool.

1. Open the engine cover and check if the coolant level in the subtank is between the LOW and FULL levels. Refill the subtank with coolant through the filler port up to the FULL level. Close the cap firmly after refilling.
2. If the subtank is empty, stop the engine, check for water leak, check the water level in the radiator, and refill the radiator and subtank with coolant.

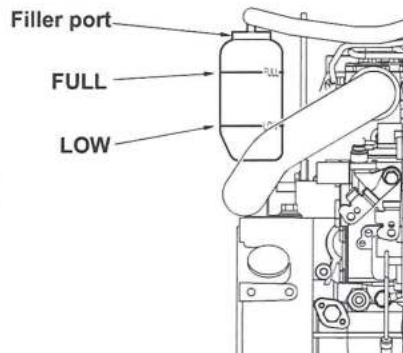

Subtank WB-C310310

Change the Coolant

! WARNING

- Coolant is hot immediately after stopping the engine. If coolant is discharged immediately, you may get burnt. Change coolant after the engine cools down.
- Do not remove the cap when the coolant is hot. Hot water may spout out. Rotate the cap slowly to relief the pressure after the coolant temperature lowers.

1. Coolant

- A new machine is filled with coolant containing long life coolant (LLC). This coolant has effects of preventing freezing and corrosion. It effects for long and may be used all over the year.
- Change coolant every two years (in autumn every two years).
- Change coolant at the shorter interval of 6 months or 250 hours if LLC is not used.
- It is recommended that LLC should be used when changing coolant.

! WARNING

- The long life coolant is toxic.
- Vomit it immediately and consult a doctor, if you swallow it by mistake.
- Wash your eyes completely with water immediately and consult a doctor, if it is put into the eyes.
- Use a container with an antifreeze mark to store long life coolant. Cap the container and store it in a place not accessible by children.

MAINTENANCE

2. Mixing ratio of coolant

The freezing temperature of coolant depends on the ratio of mixing with water and LLC. Decide the mixing ratio so that the freezing temperature becomes 5°C lower than the expected lowest temperature.

Use "city water" to mix with LLC.

Lowest temperature		-15°C or more	-25°C	-35°C
Mixing ratio		30%	41%	49%
Mixing Qty	LLC qty	0.7 L	0.9 L	1.1 L
	Water qty	1.5 L	1.3 L	1.1 L
Total coolant qty: 2.2 L		Engine only: 0.6 L	Radiator, etc.: 1.2 L	Subtank: 0.4 L

3. Procedures of changing coolant

- 1) Lower the attachment onto the ground and stop the engine.
- 2) Remove the radiator cap (1).
- 3) Open the drain cock (2) below the radiator to discharge water.
Then, remove the drain plug (3) of the cylinder block to discharge water.
- 4) Close the drain cock and drain plug, pour city water and cleaning solution, and idle the engine for approximately ten minutes.
- 5) Stop the engine and open the drain cock and drain plug to discharge water.
- 6) Close the drain cock and drain plug after discharging water. Pour city water then.
- 7) Open the drain cock and drain plug. Idle the engine at the low idling revolution and clean the cooling water system with water for ten minutes while adjusting the pouring quantity so that the radiator is always full of water.
- 8) Close the drain cock and drain plug and fill coolant containing mixed city water and LLC up to the water filler port of the radiator.
- 9) Run the engine at the low idling for five minutes and stop it then.
Internal air is discharged and the water level lowers. Refill coolant close to the water filler port and tighten the cap.
- 10) Discharge coolant from the subtank (4), clean the inside of the tank, fill the tank with coolant up to the FULL mark.

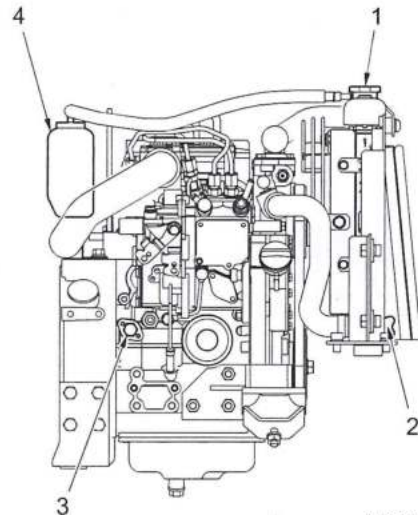

WB-C310320

MAINTENANCE

Check the Fan Belt

⚠ WARNING

- The engine is hot immediately after stopping it. You may get burnt if you touch the engine. Wait until each part cools down.
- Stop the engine and keep the key of the starter switch in safe.

NOTICE

- If belt tension is excessive, the bearings and belt will be damaged earlier.
- Replace the bolt if it has elongated and the adjustment margin is lost.
- Run the engine at high speed for 30 minutes after the belt is replaced. Check and adjust belt tension then.

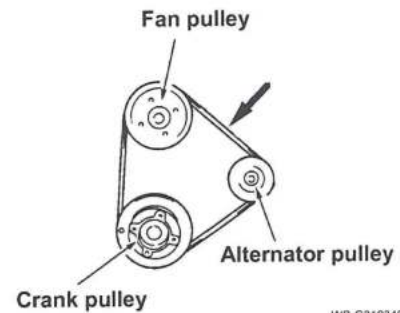

WB-C310340

1. Check

- 1) Push a point in the middle of the fan pulley and generator at approximately 98 N (10 kg). The belt tension is proper if the belt slacks by approximately 10 mm.
- 2) Replace the belt if the belt has cracks.

2. Adjustment

- 1) Loosen the bolt (1) and nut (2).
- 2) Turn the adjust bolt (3) to move the generator (3) so that the belt slacks by approximately 10 mm.
- 3) Tighten the bolt and nut.
- 4) Replace the bolt if it has elongated and the adjustment margin is lost.

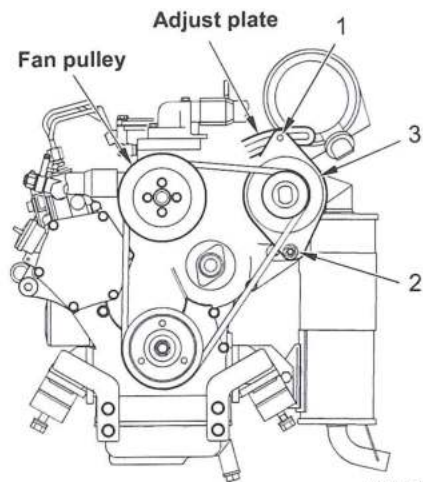

WB-C310350

MAINTENANCE

Inspect and Clean Radiator Fins and Oil Cooler Fins

CAUTION

Be sure to put on protective goggles when handling compressed air or high-pressure water in inspection of the engine. Otherwise, your eyes may be hurt by dust, scattered matters, compressed air, high-pressure water or steam.

1. Blow out dust with compressed air (at 0.2 MPa or less) from the fins.
Be careful not to damage the fins with compressed air.
2. Clean the fins with neutral detergent and city water if a lot of dust adheres to the fins.

NOTICE

Use high-pressure water and compressed air at as low pressure (0.2 MPa) as possible. Do not use a wire brush to clean the fins. A wire brush may damage the fins.

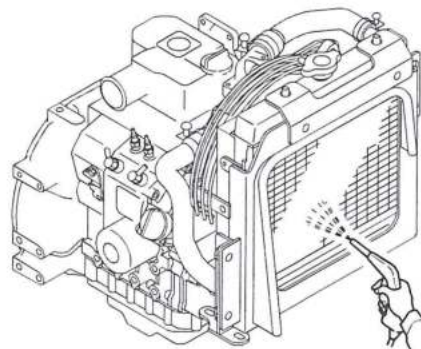

WB-C310370

MAINTENANCE

INTAKE AIR SYSTEM

Inspect and Clean Air Cleaner Element

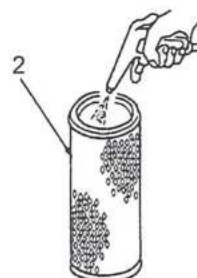
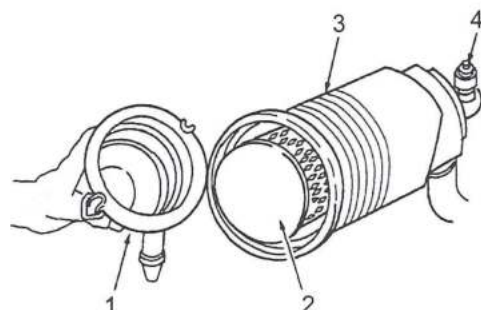

Cleaning element with air

WC-C300450

1. Stop the engine.
2. Remove the cover (1) and take out the element (2).
3. Clean the inside of the cover and the body (3).
4. Take the element holder (4) out of the dust pan and clean it.
5. Blow dry compressed air "at 0.68 MPa (7 kgf/cm²)" from inside the element to the filter up and down along the furrows. Keep a certain distance from the nozzle top to the filter (approx. 50 cm).
6. Insert a lamp (incandescent lamp) into the element and turn it on to check damages of the filter.
Do not use the filter if it has damages, pinholes, especially thin parts or damaged seal.
7. Attach the element after cleaning.
8. Attach the dust pan with the arrow mark (↑) on it upward and fix it with the clamp.

NOTICE

- Replace the element with a new one, regardless of the replacement interval, if it is dirty with lamp soot, soot or oil.
- Do not pat, hit or drop the element.

Replace Air Cleaner Element

Disassemble the air cleaner in the same manner as inspection and cleaning procedures and replace the element with a new one.

CAUTION

- Be sure to stop the engine when carrying out maintenance of the air cleaner. If it is carried out while the engine is running, dust is sucked and the engine may be damaged.
- Put on protective goggles when cleaning the element using compressed air. Otherwise, dust may be put in your eyes, which is dangerous.

MAINTENANCE

ENGINE

Check and Adjust Governor Lever

1. Check that the governor lever (1) makes firm contact with the high idle stop and the low idle speed limit screw when the engine speed control is in the full speed or low idle speed positions.
2. If the governor lever does not make proper contact with the high idle stop or the low idle speed limit screw, adjust the throttle cable or linkage as necessary.

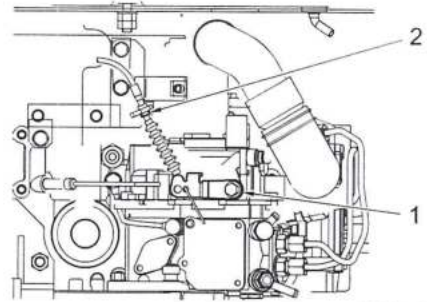

WB-C310470

NOTICE

Do not change the no-load minimum or maximum revolution with the limit bolt. Otherwise, the safety and/or performance of the machine may be deteriorated or the service life of the machine may be reduced.

Adjust Intake Valve and Exhaust Valve Clearance

Proper adjustment is necessary to maintain the correct timing for opening and closing the valves. Improper adjustment will cause the engine to run noisily, resulting in poor engine performance and engine damage.

Check of Fuel Injection System

Proper operation of the fuel injectors is required to obtain the optimum injection pattern for full engine performance. The EPA/ARB requires that you have the injectors inspected, cleaned and tested every 1500 hours.

Inspect Crankcase Breather System

The crankcase breather system must work properly so that the engine meets the exhaust gas regulations for long. Inquire our service office about the necessary works.

Clean Coolant System

Rust and scale adhere to the coolant system naturally in long-term use, resulting in bad cooling. As a result, the cooling efficiency is reduced, the engine oil is not cooled sufficiently and oil is deteriorated earlier.

Lap Intake and Exhaust Valves

Adjustment is necessary to maintain proper contact of the valves and seats.

ELECTRIC SYSTEM

Replace the Fuses

NOTICE	
•	Be sure to set the engine key switch to the OFF position before replacing the fuses.
•	Do not use wires, silver foils, etc. instead of fuses. If such materials are used, the wires may overheat and burn, resulting in a fire.

1. Set the engine key switch key to the OFF position.
2. Take off the fuse cover.
3. Replace the blown fuse with a new fuse of the same capacity.

	Fuse capacity	Circuit name
1	5 A	Warning lamps (three), hour meter
2	5 A	Fuel pump
3	10 A	Boom light, horn
4	20 A	Engine stop

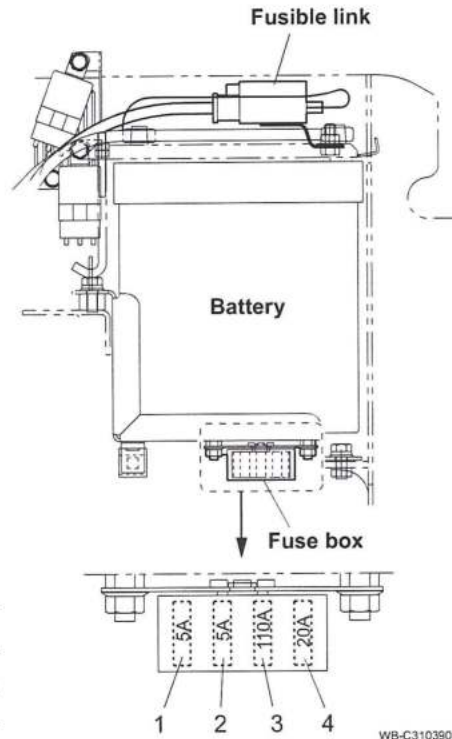

Replace the Fusible Link

If power is not turned on even though the engine key switch is set to the ON position, the fusible link between the battery and the engine key switch circuit may have blown out. Remove and check the fusible link. Replace it with a new fusible link, if it has blown out.

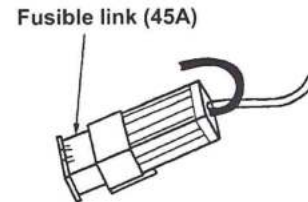

MAINTENANCE

Check the Battery

⚠ WARNING

- The battery produces inflammable hydrogen gas. It ignites or explodes if fire is nearby. Never bring fire close to the battery or strike a spark near it.
- Never place any tool, metallic object or inflammable matter on or near the battery. The battery may possibly ignite and explode if it short-circuits.
- The battery liquid (diluted sulfuric acid) may cause loss of eyesight or burning. If it is put into the eyes or on the skin or clothes, wash with much water immediately and consult a doctor.
- Be sure to put on protective goggles when handling the battery.
- Be sure to confirm that the battery handles and handle mounting positions are firm before moving up the battery.

Refill battery liquid

Inspect the electrolyte level look at the indicator or sight level line on the battery.

Maintain the level to the upper level of the sight level line with distilled water when required.

Level of electrolyte must never fall below tops of plates.

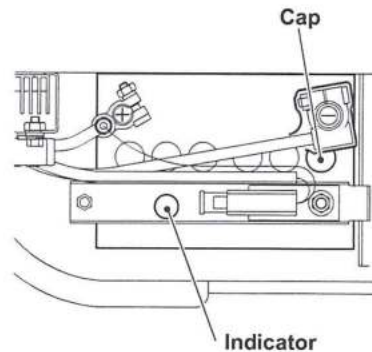

Clean the battery terminals

NOTICE

- Be sure to keep the engine stopping during work.
- Be careful during work not to short-circuit the positive and negative terminals of the battery with a tool, etc.
- Disconnect the battery cable from the negative terminal first. Connect it to the negative terminal last.
- Tighten the terminals firmly.

Indication of indicator

The standard recharging conditions and liquid levels are as shown below.

Good  (Blue)

Needs recharging  (White)

Liquid insufficient  (Red)

WB-C310400

1. Clean the terminals if they are dirty or corroded. (Pour warm water onto the terminals and wipe them if they are corroded and white powder sticks on them.)
2. Detach the terminals and polish them with a wire brush or sandpaper if they are corroded remarkably.
3. Apply grease, etc. thinly to the terminals after cleaning and tightening.

ELECTRIC SYSTEM DIAGRAM

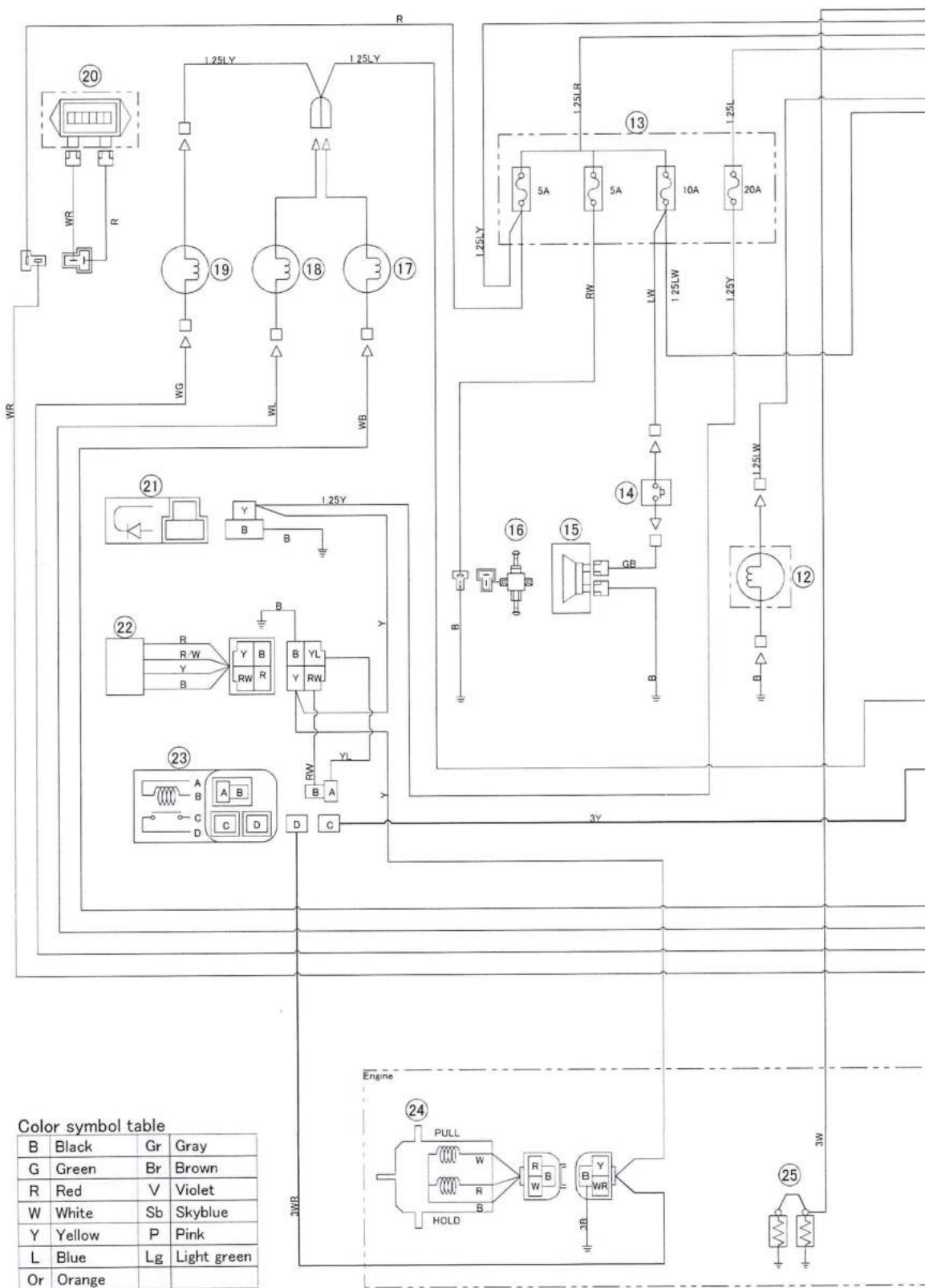

Color symbol table

B	Black	Gr	Gray
G	Green	Br	Brown
R	Red	V	Violet
W	White	Sb	Skyblue
Y	Yellow	P	Pink
L	Blue	Lg	Light green
Or	Orange		

MAINTENANCE

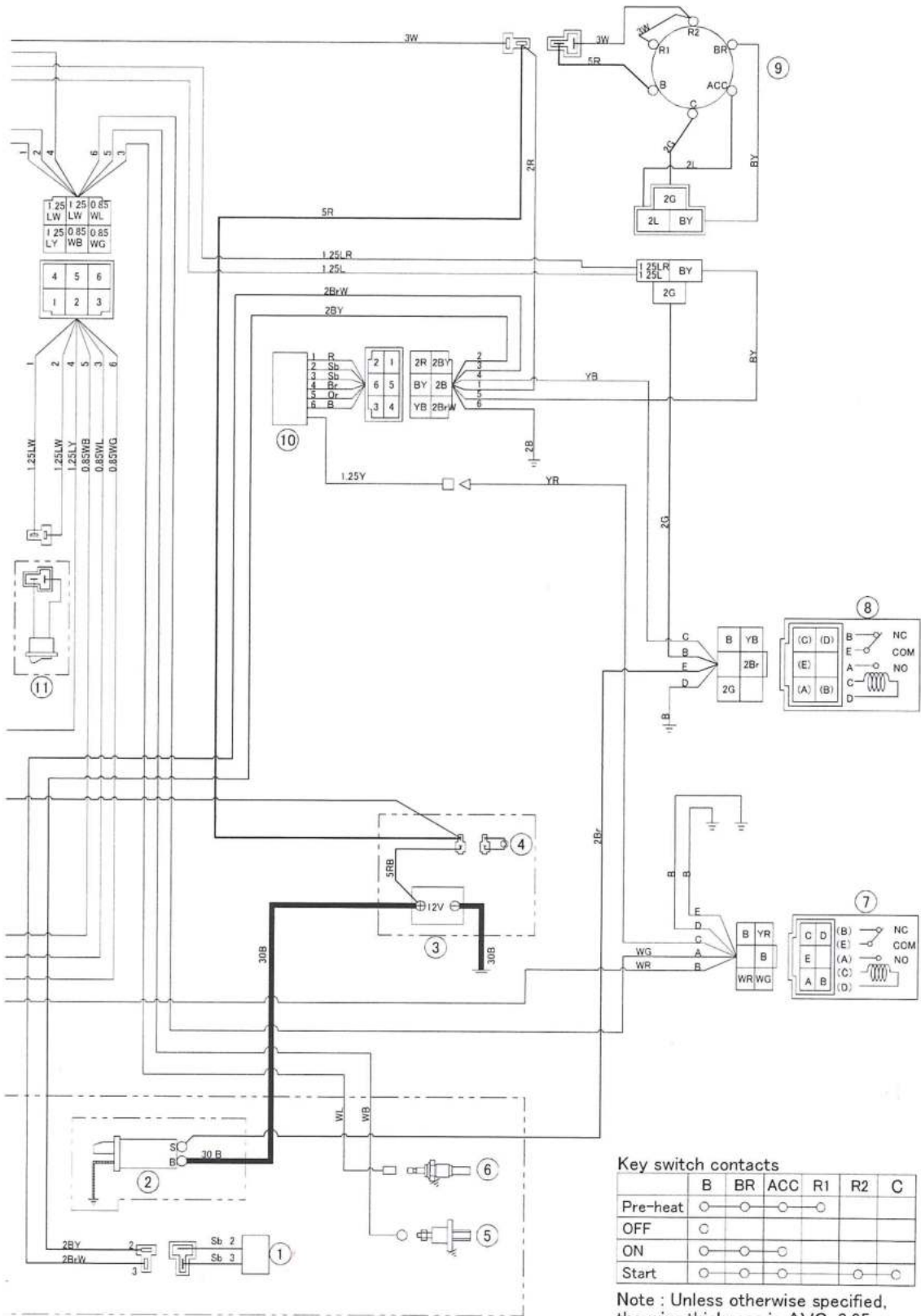

Key switch contacts

	B	BR	ACC	R1	R2	C
Pre-heat	○	○	○	○		
OFF	○					
ON	○	○	○			
Start	○	○	○	○	○	

Note : Unless otherwise specified, the wire thickness is AVS-0.85.

MAINTENANCE

No.	Name	No.	Name
1	Generator	14	Horn switch
2	Starting motor	15	Horn
3	Battery	16	Fuel pump
4	Fusible link (45A)	17	Engine oil pressure warning lamp
5	Engine oil pressure switch	18	Coolant temperature warning lamp
6	Water temperature sensor	19	Battery charge warning lamp
7	Charge lamp / Hour meter relay	20	Hour meter
8	Safety relay	21	Diode
9	Engine key switch	22	Timer (1sec)
10	Current limiter	23	Engine stop relay
11	Light switch	24	Engine stop solenoid
12	Boom light	25	Glow plug
13	Fuse box		

MAINTENANCE

TIGHTEN BOLTS

Retighten loose bolts in daily inspection. Be sure to make up for lacking bolts. Check and retighten the bolts after the first 50 hours if a new machine is used.

Special Tightening Positions

The bolts shown below bear large forces. Tighten them at the torque shown in the table below. When replacing the bolts in these positions, apply molybdenum disulfide grease to the threads and the bearing surfaces of the nuts and tighten at the specified torque.

As for the travel reduction gear and drive sprocket of the travel unit, apply thread lock cement to the threads of the bolts

1. Travel unit

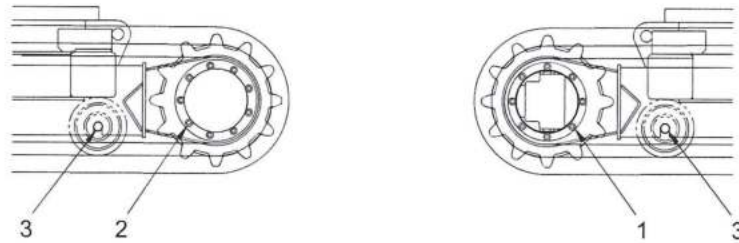

WB-C310410

No.	Tightening position	Bolt size	Wrench size (mm)	Tightening torque	
				(N·m)	(kgf·m)
1	Travel reduction gear	M10	Bar 8	54	5.5
2	Drive sprocket	M10	Bar 8	54	5.5
3	Lower roller	M12	19	97	9.9

2. Swing unit

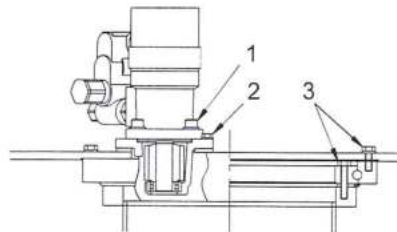

WB-C310420

No.	Tightening position	Bolt size	Wrench size (mm)	Tightening torque	
				(N·m)	(kgf·m)
1	Swing motor	M12	Bar 10	97	9.9
2	Swing gear case	M10 P1.25	17	55	5.6
3	Swing bearing	M10	17	59	6.0

MAINTENANCE

3. Engine

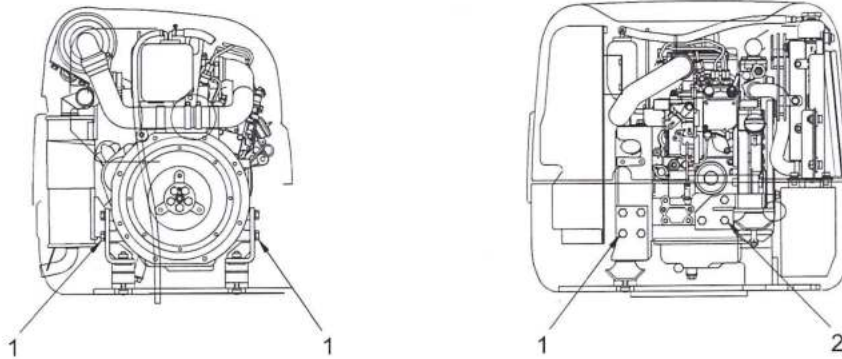

WB-C310430

No.	Tightening position	Bolt size	Wrench size (mm)	Tightening torque	
				(N·m)	(kgf·m)
1	Engine bracket (rear)	M10	17	69	7.0
2	Engine bracket (front)	M10	17	69	7.0

Standard Tightening Torques

Tighten the bolts and nuts other than those in the special tightening positions at the torques shown below.

10T Heat-treatment bolts						High-pressure hose union nut		
Bolt size	Wrench size (mm)	Coarse thread		Fine thread		Hose size (inch)	(N·m)	(kgf·m)
		(N·m)	(kgf·m)	(N·m)	(kgf·m)			
M8	13	23	2.3	25	2.5	1/4"	25	2.5
M10	17	47	4.8	50	5.1	3/8"	49	5.0
M12	19	83	8.5	91	9.3	1/2"	59	6.0
M14	22	134	13.7	135	13.8	3/4"	118	12.0
M16	24	208	21.2	221	22.5	1"	137	14.0
M20	30	411	41.9	452	46.1	1-1/4"	167	17.0
M24	36	715	72.9	811	82.7			

HANDLING IN COLD WEATHER

At low temperature, the engine hardly starts and coolant is subject to freezing. Make preparation for cold weather as shown below.

Fuel

In cold weather, fuel may be frozen and it may be difficult to start the engine.

Use fuel (light oil) appropriate for the temperature.

Coolant

LLC has been mixed in coolant of this machine before shipment. A mark at a temperature on the label stuck behind the radiator shows the freezing point.

If the lowest temperature may be lower than it, refer to the antifreeze mixing ratio table and adjust the concentration. Exchange the coolant every two years (in autumn every two years).



CJ-C400430

Lubricant and grease

Exchange engine oil and hydraulic oil with proper oil having viscosity appropriate for the outer temperature. Refer to RECOMMENDED LUBRICATION TABLE for the specified viscosity.

Battery

In cold weather, larger discharge current flows when starting the engine and the battery performance is also reduced. If the battery is almost discharged, battery liquid may be frozen. Recharge the battery almost fully and keep it warm to start the engine free from troubles next morning.

Precautions when finishing work

- Remove mud and water from the cylinder rod to prevent the cylinder rod seals from being damaged.
- Put plates on dry and firm ground and park the machine on them in order to prevent the crawlers from freezing.
- Discharge water from the fuel tank to prevent fuel from freezing.

LONG TERM STORAGE

NOTICE

To protect the cylinder rod from rust, set the machine to the posture for long term storage.

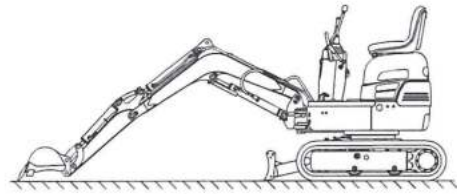

Posture for long term storage

WB-C310440

Before storage

- Clean the machine.
- Carry out lubrication, greasing and oil changing of each part.
- Apply grease to the exposed piston rods of the hydraulic cylinders.
- Dismount the batteries, recharge them fully, and store them. Alternatively, disconnect the negative terminals.

During storage

⚠ CAUTION

If you have to operate the machine indoors to prevent rust, keep good ventilation and gas poisoning by window or entrance.

- Warm up the machine and carry out traveling, swinging and a series of operations, including attachment operations, once every month to prevent rust and keep lubrication condition while the machine is not used for long.
- Wipe off grease from the hydraulic cylinder before moving the attachment.

After storage

- Check the lubrication and greasing conditions of each part and the coolant level.
- Wipe off grease from the hydraulic cylinder.
- Start the engine, warm it up, and carry out traveling, swinging and attachment operations several times repeatedly to run in each part.

SPECIFICATIONS

SPECIFICATIONS

SPEED AND GRADEABILITY

Swing speed	8.7 min ⁻¹
Travel speed (low/high)	1.7/3.5 km/h
Gradeability	58% (30 degrees)

ENGINE

Engine model	Yanmar 2TNV70-PIKX
Type	Vertical in-line, water cooled, 4-cycle diesel engine (Ball-type swirl chamber)
No. of cyl. - bore x stroke	2-70 mm x 74 mm
Displacement	0.569 L
Max. rated output	7.3 kW / 2400 min ⁻¹

MASS

Machine mass	890 kg
Average ground bearing pressure	26 kPa

CAPACITY

Fuel		8.5 L
Hydraulic oil	Tank level	8.2 L
	Total quantity	14.0 L
Engine oil	Maximum	1.8 L
	Minimum	1.2 L
Coolant	Engine only	0.6 L
	Total quantity	2.2 L

SPECIFICATIONS

BUCKET

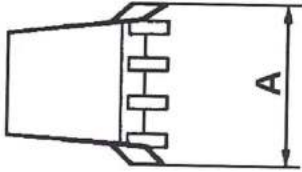

- ⊕ = Standard
- ☑ = Compatible
- ☒ = Not Compatible

Bucket capacity ISO (JIS) (m ³)	Width (mm) External teeth (A)	No. of teeth	Mass (kg)	Utilizzo	
				Standard arm	Long arm
0,023	370	3	24	⊕ General digging	☑ Loading
0,021	320	3	22	☑ General digging	⊕ Ditch digging
0,016	220	2	16	☑ General digging	☑ General digging

Using buckets larger than the standard, where permitted, must be done with great caution to avoid tipping the machine over and damaging structures.

SPECIFICATIONS

DIMENSIONS

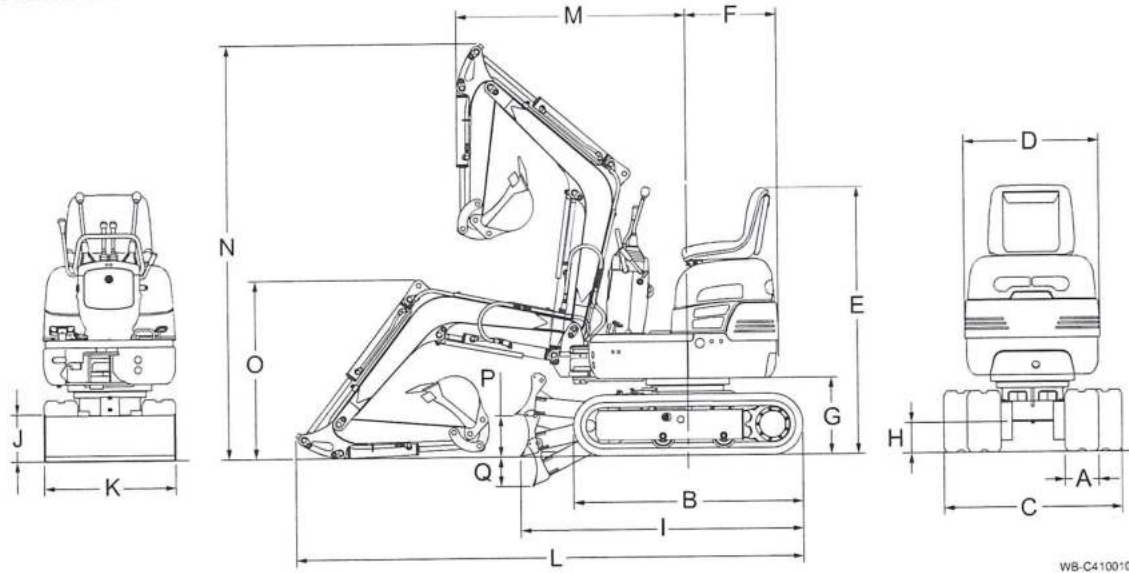

WB-C410010

Unit: mm

Symbol	Item		Dimension
A	Crawler shoe width		180
B	Crawler overall length		1220
C	Crawler overall width	Contracted crawlers	700
		Extended crawlers	950
D	Upper structure overall width		720
E	Overall height of base machine		1405
F	Swing radius		485
G	Clearance height under upper structure		405
H	Ground clearance of undercarriage		160
I	Undercarriage overall length		1500
J	Blade height		245
K	Blade width		700
L	Overall length	Blade forward	2700
		Blade backward	2980
M	Minimum radius of equipment and attachment		1220
N	Overall height at minimum radius of equipment and attachment		2180
O	Attachment height in transport posture		940
P	Blade maximum lifting		220
Q	Blade maximum lowering		155

SPECIFICATIONS

WORKING RANGE

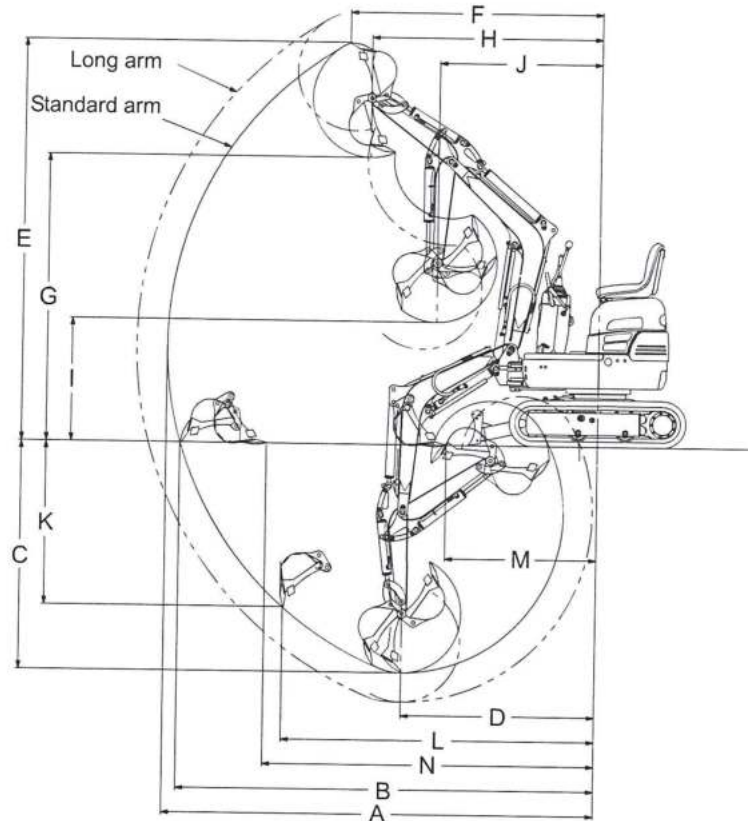

WB-C410020

Unit: mm

Symbol	Name	Standard arm	Long arm
A	Maximum reach	2980	3190
B	Maximum reach at ground reference plane	2880	3100
C	Maximum digging depth	1570	1770
D	Reach at maximum digging depth	1330	1340
E	Maximum height of cutting edge	2755	2950
F	Reach at maximum height	1740	1820
G	Maximum dumping height	1970	2150
H	Reach at maximum dumping height	1590	1700
I	Minimum dumping height	850	660
J	Reach at minimum dumping height	1120	1220
K	Maximum vertical digging depth	1175	1400
L	Reach at maximum vertical digging depth	2160	2140
M	Minimum level floor radius	1040	990
N	Maximum level floor radius	2290	2500

SPECIFICATIONS

WORKING RANGE FOR OFFSET DIGGING

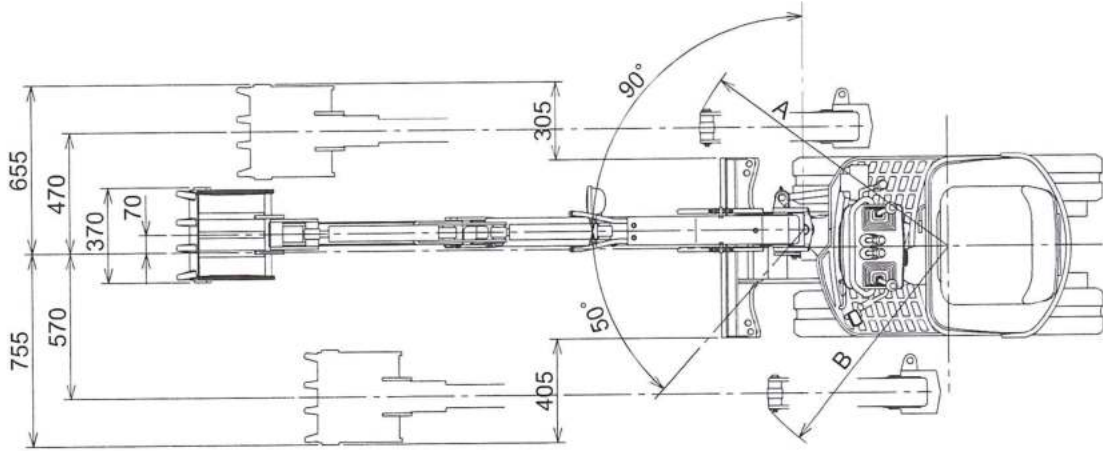

WB-C410030

Unit: mm

Minimum radius of equipment at maximum front offset	A	Left boom swing	1105
	B	Right boom swing	950

SPECIFICATIONS

This page is intentionally left blank

MINI EXCAVATOR

9VXE

PUBLISHED: JUNE 2012

IHIMER S.p.A.

ITALY

/// IHIMER



IHIMER Spa
53037 San Gimignano - Loc. Cusona (SI) - Italy

info@ihimer.com | www.ihimer.com