

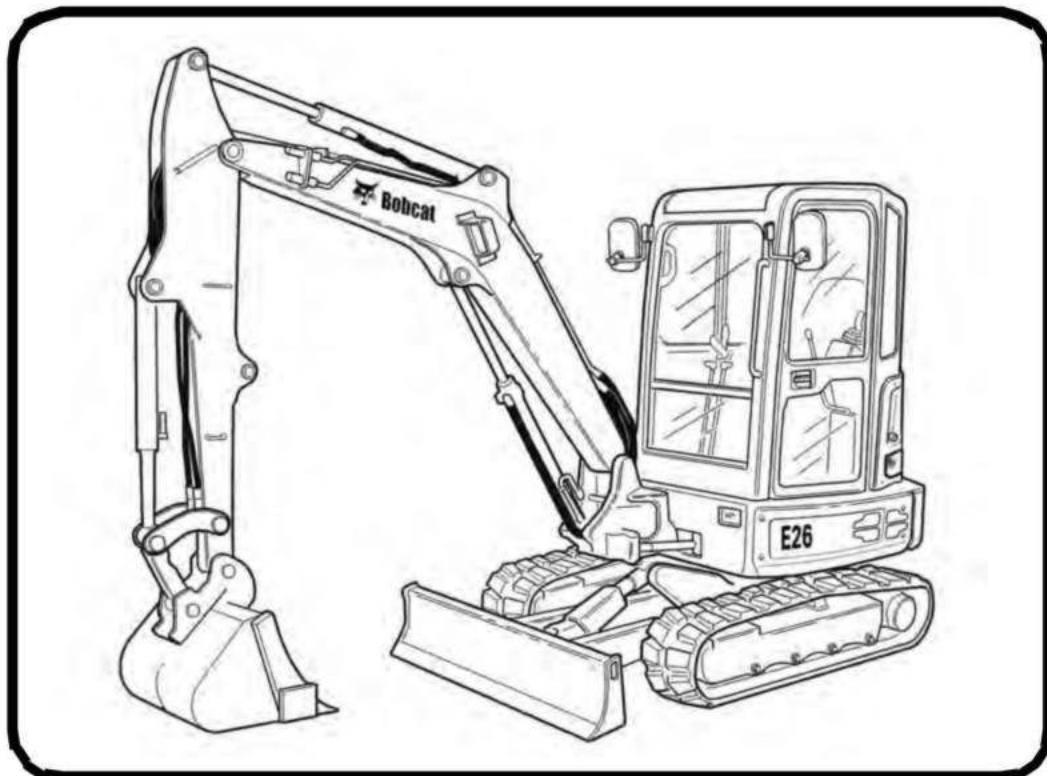

Bobcat®

Operation & Maintenance Manual E26 Compact Excavator

S/N AJRY11001 & Above
S/N B33211001 & Above



Dealer Copy -- Not for Resale



OPERATOR SAFETY WARNING

! WARNING

Operator must have instructions before operating the machine. Untrained operators can cause injury or death.

W-2001-0502

! Safety Alert Symbol: This symbol with a warning statement, means: "Warning, be alert! Your safety is involved!" Carefully read the message that follows.

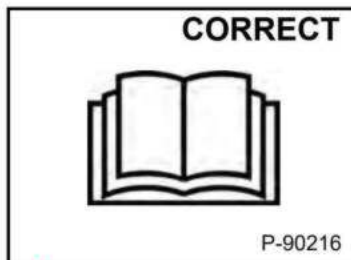

! Never operate without instructions.

! Read machine signs, and Operation & Maintenance Manual, and Operator's Handbook.

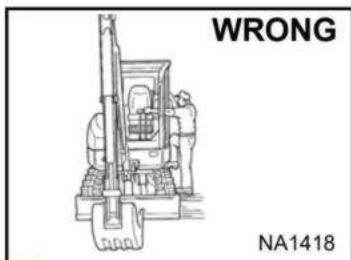

! Do not grasp control handles when entering cab / canopy.

! Be sure controls are in neutral before starting.

! Sound horn and check behind machine before starting.

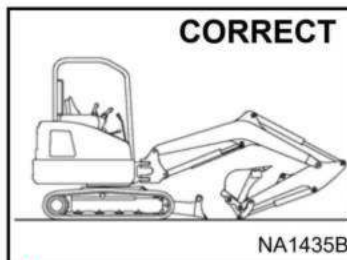

! Never operate without approved cab / canopy.

! Never modify equipment.

! Never use attachments not approved by Bobcat Company.

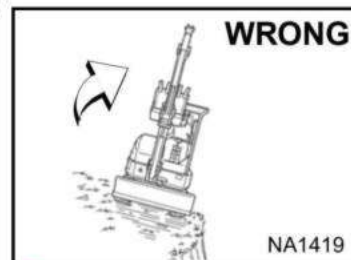

! Avoid steep areas or banks that could break away.

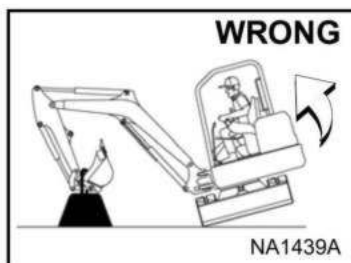

! Use caution to avoid tipping - do not swing heavy load over side of track.

! Operate on flat, level ground.

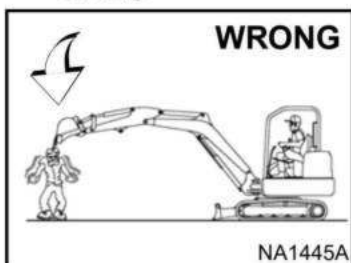

! Keep bystanders out of maximum reach area.

! Do not travel or turn with bucket extended.

! Never carry riders.

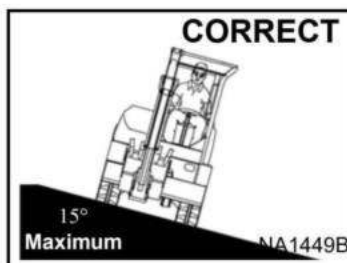

! Never exceed a 15° slope to the side.

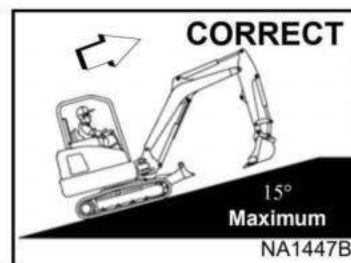

! Never travel up a slope that exceeds 15°.

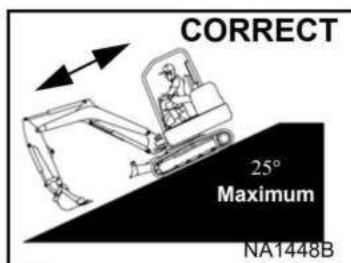

! Never exceed 25° when going down or backing up a slope.

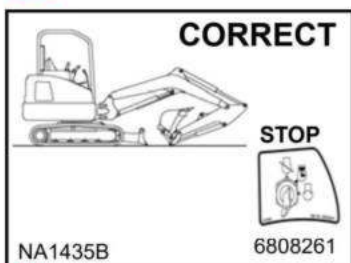

! To leave excavator, lower the work equipment and the blade to the ground. Stop the engine.

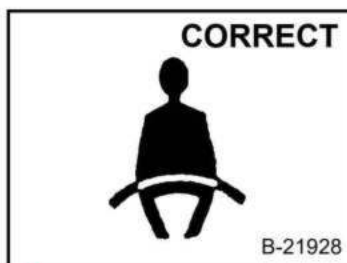

! Fasten seat belt securely.

! Operate controls only from operator's seat.

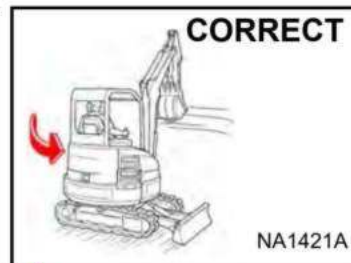

! Look in the direction of rotation and make sure no bystanders are in the work area.

SAFETY EQUIPMENT

The excavator must be equipped with safety items necessary for each job. Ask your dealer about attachments and accessories.

1. SEAT BELT: Check belt fasteners and check for damaged webbing or buckle.
2. OPERATOR CAB / CANOPY (ROPS and TOPS): Check condition and mounting hardware.
3. OPERATOR'S HANDBOOK: Must be in the cab / canopy.
4. LEFT HAND CONSOLE: When raised must deactivate the travel and hydraulic functions.
5. SAFETY SIGNS (DECALS): Replace if damaged.
6. GRAB HANDLES: Replace if damaged.
7. INTEGRATED SLEW LOCK BRAKE.
8. SAFETY TREAD.: Replace if damaged.



Bobcat®

CONTENTS

FOREWORD	5
SAFETY AND TRAINING RESOURCES	13
OPERATING INSTRUCTIONS	23
PREVENTIVE MAINTENANCE	81
SYSTEM SETUP AND ANALYSIS	129
MACHINE SIGN TRANSLATIONS	137
SPECIFICATIONS	165
WARRANTY	177
ALPHABETICAL INDEX	181

REFERENCE INFORMATION

Write the correct information for YOUR Bobcat excavator in the spaces below. Always use these numbers when referring to your Bobcat excavator.

Excavator Serial Number _____
Engine Serial Number _____

NOTES:

YOUR BOBCAT DEALER:

ADDRESS:

PHONE:

Bobcat Company
P.O. Box 128
Gwinner, ND 58040-0128
UNITED STATES OF AMERICA

Doosan Benelux SA
Drève Richelle 167
B-1410 Waterloo
BELGIUM

Dealer Copy -- Not for Resale



Bobcat®

Dealer Copy -- Not for Resale

FOREWORD

This Operation & Maintenance Manual was written to give the owner / operator instructions on the safe operation and maintenance of the Bobcat excavator. READ AND UNDERSTAND THIS OPERATION & MAINTENANCE MANUAL BEFORE OPERATING YOUR BOBCAT EXCAVATOR. If you have any questions, see your Bobcat dealer. This manual can illustrate options and accessories not installed on your excavator.

BOBCAT COMPANY IS ISO 9001 CERTIFIED	7
REGULAR MAINTENANCE ITEMS	7
SERIAL NUMBER LOCATIONS	8
Excavator Serial Number	8
Engine Serial Number	8
DELIVERY REPORT	8
EXCAVATOR IDENTIFICATION	9
FEATURES, ACCESSORIES AND ATTACHMENTS	10
Standard Items	10
Options And Accessories	10
Attachments	10
Buckets Available	10
Falling Object Guards (FOGS)	11
Special Applications Kit	11
Special Applications Kit Inspection And Maintenance	11

Dealer Copy -- Not for Resale



Bobcat®

Dealer Copy -- Not for Resale

BOBCAT COMPANY IS ISO 9001 CERTIFIED













ISO 9001 is an international standard that specifies requirements for a quality management system that controls the processes and procedures which we use to design, develop, manufacture and distribute Bobcat products.

British Standards Institute (**BSI**) is the Certified Registrar Bobcat Company chose to assess the Company's compliance with the ISO 9001 at Bobcat's manufacturing facilities in Gwinner and Bismarck, North Dakota (U.S.A.), Pontchateau (France), Dobris (Czech Republic) and the Bobcat corporate offices (Gwinner, Bismarck and West Fargo) in North Dakota. Only certified assessors, like BSI, can grant registrations.

ISO 9001 means that as a company we say what we do and do what we say. In other words, we have established procedures and policies, and we provide evidence that the procedures and policies are followed.

CALIFORNIA PROPOSITION 65 WARNING
 Diesel engine exhaust and some of its constituents are known to the State of California to cause cancer, birth defects and other reproductive harm.

REGULAR MAINTENANCE ITEMS

	ENGINE OIL FILTER 6657635		BATTERY 6670251
	FUEL FILTER 6667352		HYDRAULIC FILL / BREATHER CAP 6692836
	AIR FILTER, Outer 6673752		FLUID, Hydraulic / Hydrostatic 6903117 - 9,5 L (2.5 U.S. gal) 6903118 - 18,9 L (5 U.S. gal) 6903119 - 208 L (55 U.S. gal)
	AIR FILTER, Inner 6673753		
	PRIMARY HYDRAULIC FILTER 6661248 CASE DRAIN HYDRAULIC FILTER 7009365		ANTI-FREEZE, Propylene Glycol 6983128 - Premixed 6983129 - Concentrate
			RADIATOR CAP 7022636
ENGINE OIL 6903105 SAE 15W40 CE/SG (12 qt) 6903107 SAE 10W30 CE/SG (12 qt) 6903109 SAE 30W CE/SG (12 qt) 6903113 SAE 15W40 CE/SG (2.5 U.S. gal) 6903112 SAE 10W30 CE/SG (2.5 U.S. gal) 6903111 SAE 30W CE/SG (2.5 US gal)		ENGINE OIL 6903106 SAE 15W40 CE/SG (1 U.S. gal) 6903108 SAE 10W30 CE/SG (1 U.S. gal) 6903110 SAE 30W CE/SG (1 U.S. gal)	

NOTE: Always verify Part Numbers with your Bobcat dealer.

Dealer Copy -- Not for Resale

SERIAL NUMBER LOCATIONS

Always use the serial number of the excavator when requesting service information or when ordering parts. Early or later models (identification made by serial number) can use different parts, or it can be necessary to use a different procedure in doing a specific service operation.

Excavator Serial Number

Figure 1

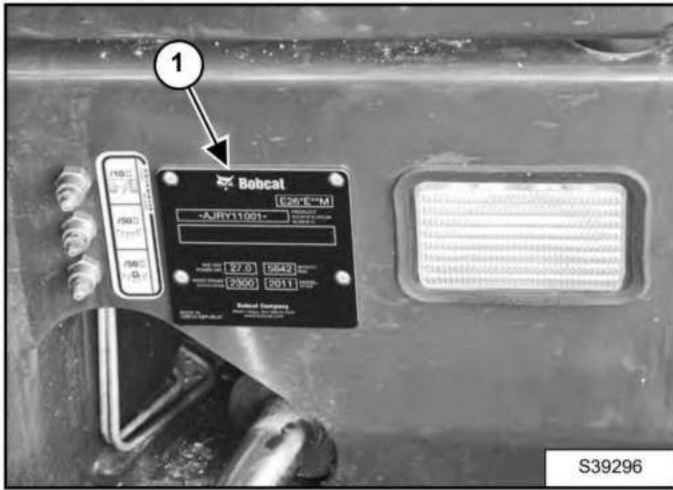

The excavator serial number plate (Item 1) [Figure 1] is located on the frame of the machine in the location shown.

Figure 2

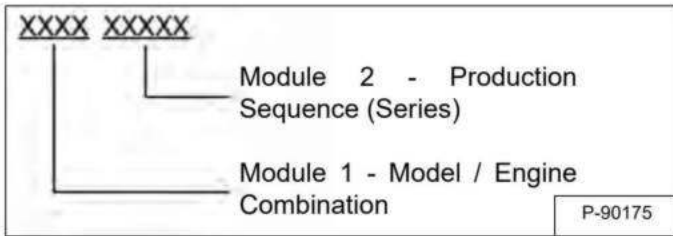

Explanation of excavator Serial Number [Figure 2]:

1. The four digit Model / Engine Combination Module number identifies the model number and engine combination.
2. The five digit Production Sequence Number identifies the order which the excavator is produced.

Engine Serial Number

Figure 3

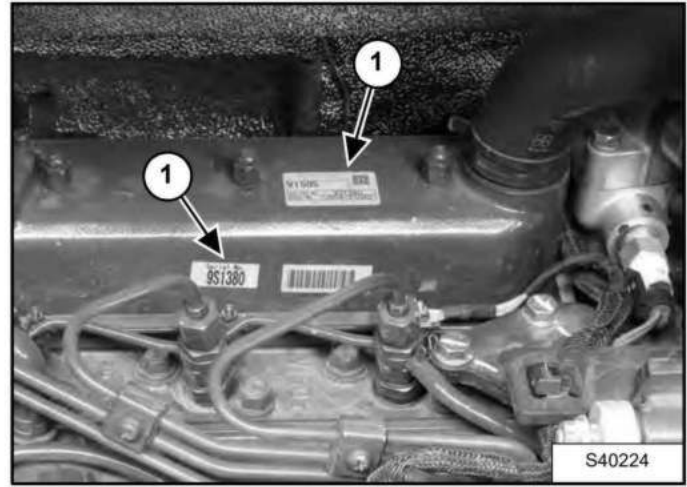

The engine serial number is located on the top cover (two locations) (Item 1) [Figure 3].

DELIVERY REPORT

Figure 4

The delivery report [Figure 4] must be completed by the dealer and signed by the owner or operator when the Bobcat excavator is delivered. An explanation of the form must be given to the owner. Make sure it is completed in full.

EXCAVATOR IDENTIFICATION

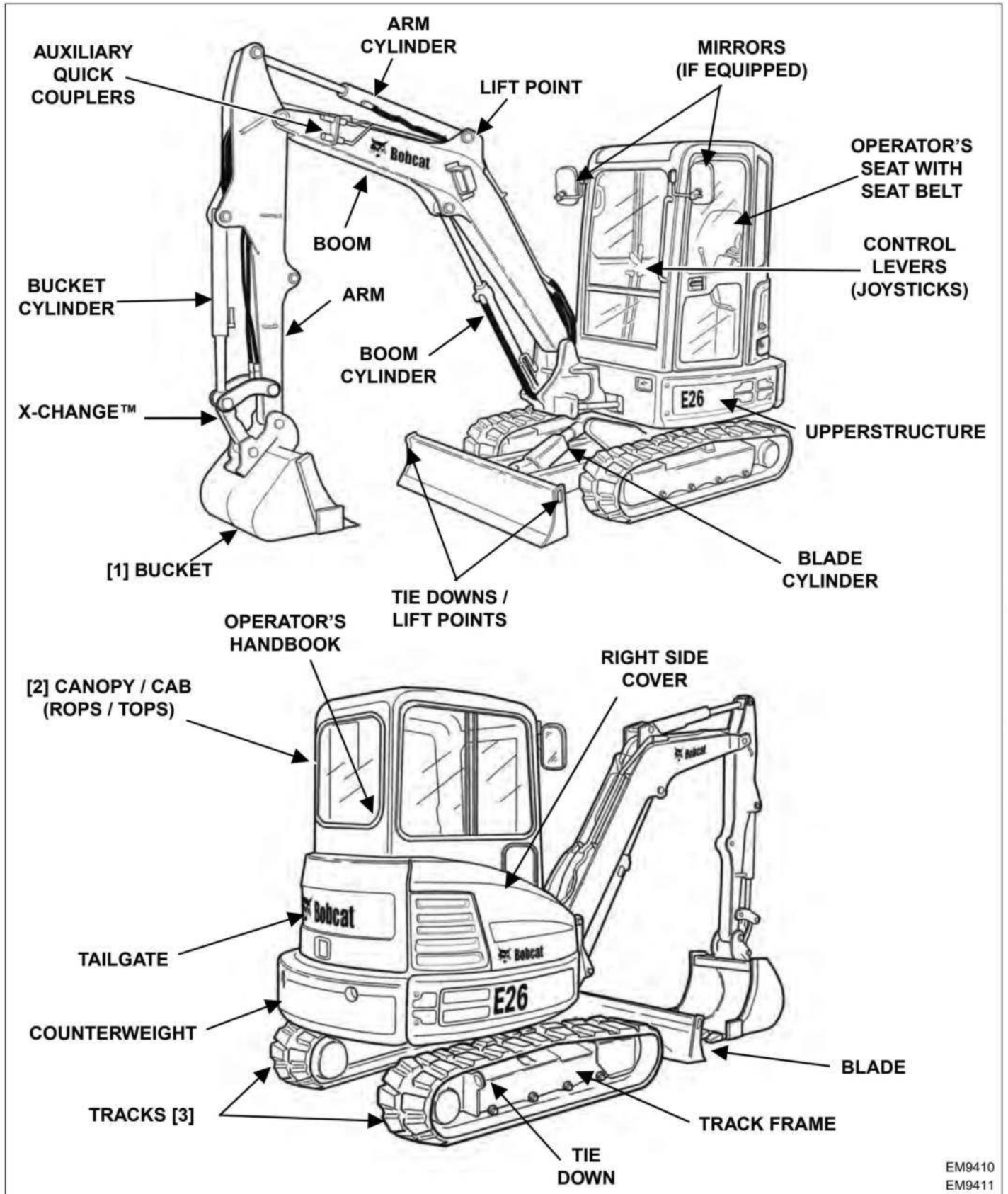

- [1] BUCKET - Several different buckets and other attachments are available from the Bobcat excavator.
- [2] ROPS, TOPS - (Roll Over Protective Structure / Tip Over Protective Structure) as standard equipment. The ROPS / TOPS meets ISO 12117-2 AND ISO 12117.
- [3] TRACKS - Optional tracks are available.

Dealer Copy -- Not for Resale

EM9410
EM9411

FEATURES, ACCESSORIES AND ATTACHMENTS

Standard Items

Model E26 Bobcat excavators are equipped with the following standard items:

- 1515 mm (59.6 in) Dozer Blade
- Canopy with ROPS / TOPS Approval
- 300 mm (11.8 in) Rubber Tracks
- Two-Speed Travel
- Auto Shift Drive Motors
- Auxiliary Hydraulics
- Engine Speed Control Dial With Auto Idle Feature
- Hydraulic and Travel Control Lockouts
- Work Lights - Boom and Frame Mounted
- Engine and Hydraulic System Monitor with Shut Down
- Horn
- Hydraulic Joystick Controls
- Suspension Seat
- Retractable Seat Belt
- Spark Arrester Muffler
- Advanced Diagnostics
- X-Change™
- Counterweight

Options And Accessories

Below is a list of some equipment available from your Bobcat excavator dealer as Dealer and / or Factory Installed Accessories and Factory Installed Options. See your Bobcat dealer for other available options, accessories and attachments.

- Battery (with 600 CCA)
- Enclosed Cab With Heater and Air Conditioning
- Travel Motion Alarm
- Keyless Start
- Canopy / Cab Mounted Lights
- Long Arm
- Direct to Tank Auxiliary Hydraulics
- Counterweight (Additional)
- Second Auxiliary Hydraulics
- Top Guard Kit (FOGS)
- Special Application Kit
- RFID Kit (Security Key Start System)

Specifications subject to change without notice and standard items can vary.

Attachments

These and other attachments are approved for use on this model Bobcat excavator. Do not use unapproved attachments. Attachments not manufactured by Bobcat can not be approved.

The versatile Bobcat excavator quickly turns into a multi-job machine with a variety of attachments.

See your Bobcat dealer for information about approved attachments and attachment Operation & Maintenance Manuals.

- Auger
- Breaker
- Hydraulic Clamp
- 3-Tined Grapple
- Compactor
- Power Tilt
- Ripper
- Hydro tilt
- Packer wheel
- Lazer Receiver

Buckets Available

Increase the versatility of your Bobcat excavator with a variety of bucket sizes.

Many bucket styles, widths and different capacities are available for a variety of different applications. They include Trenching, Digging, Grading, Tilt, to name a few. See your Bobcat dealer for the correct bucket for your Bobcat excavator and application.

FEATURES, ACCESSORIES AND ATTACHMENTS (CONT'D)

Falling Object Guards (FOGS)

Figure 5

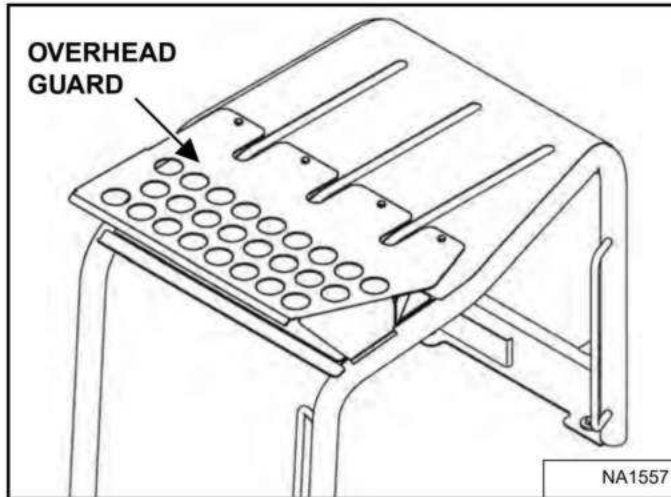

Available for special applications that require protection from smaller objects that can fall on the canopy / cab or restrict material from entering canopy / cab openings **[Figure 5]** and **[Figure 6]**.

The excavator must have the overhead guard **[Figure 5]** installed to meet the top guard requirements in ISO 10262.

See your Bobcat Dealer for more information.

Special Applications Kit

Figure 6

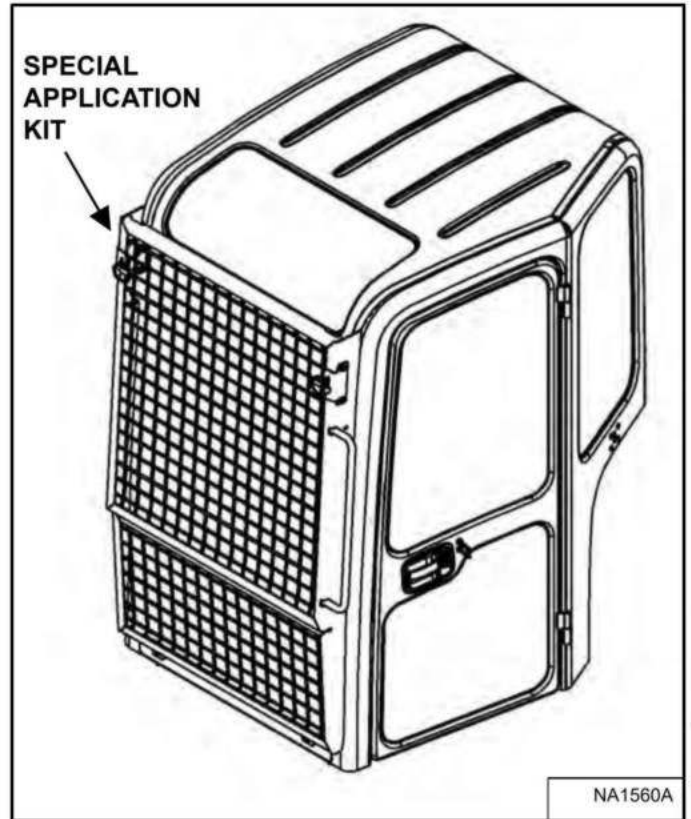

The excavator must have the special applications kit **[Figure 6]** installed to meet the front guard requirements in ISO 10262 - level 1.

Kit includes an upper and lower screen guard.

See your Bobcat Dealer for more information.

Special Applications Kit Inspection And Maintenance

The Special Applications Kit must be regularly inspected and maintained. Inspect the screen for damage. Replace parts as necessary.

Dealer Copy -- Not for Resale



Bobcat®

Dealer Copy -- Not for Resale

SAFETY AND TRAINING RESOURCES

SAFETY INSTRUCTIONS	15
Before Operation	15
Safe Operation Is The Operator's Responsibility	16
Safe Operation Needs A Qualified Operator	16
Avoid Silica Dust	17
FIRE PREVENTION	17
Maintenance	17
Operation	17
Electrical	17
Hydraulic System	18
Fueling	18
Starting	18
Spark Arrester Exhaust System	18
Welding And Grinding	18
Fire Extinguishers	18
PUBLICATIONS AND TRAINING RESOURCES	19
MACHINE SIGNS (DECALS)	20
No-Text Safety Signs	22

Dealer Copy -- Not for Resale



Bobcat®

Dealer Copy -- Not for Resale

SAFETY INSTRUCTIONS

Before Operation

Carefully follow the operating and maintenance instructions in this manual.

The Bobcat excavator is highly maneuverable and compact. It is rugged and useful under a wide variety of conditions. This presents an operator with hazards associated with off highway, rough terrain applications, common with Bobcat excavator usage.

The Bobcat excavator has an internal combustion engine with resultant heat and exhaust. All exhaust gases can kill or cause illness so use the excavator with adequate ventilation.

The dealer explains the capabilities and restrictions of the Bobcat excavator and attachment for each application. The dealer demonstrates the safe operation according to Bobcat instructional materials, which are also available to operators. The dealer can also identify unsafe modifications or use of unapproved attachments. The attachments and buckets are designed for a Rated Lift Capacity. They are designed for secure fastening to the Bobcat excavator. The user must check with the dealer, or Bobcat literature, to determine safe loads of materials of specified densities for the machine - attachment combination.

The following publications and training materials provide information on the safe use and maintenance of the Bobcat machine and attachments:

- The Delivery Report is used to assure that complete instructions have been given to the new owner and that the machine and attachment is in safe operating condition.
- The Operation & Maintenance Manual delivered with the machine or attachment gives operating information as well as routine maintenance and service procedures. It is a part of the machine and can be stored in a container provided on the machine. Replacement Operation & Maintenance Manuals can be ordered from your Bobcat dealer.
- Machine signs (decals) instruct on the safe operation and care of your Bobcat machine or attachment. The signs and their locations are shown in the Operation & Maintenance Manual. Replacement signs are available from your Bobcat dealer.

- An Operator's Handbook is fastened to the operator cab of the excavator. It's brief instructions are convenient to the operator. The handbook is available from your dealer in an English edition or one of many other languages. See your Bobcat dealer for more information on translated versions.
- The AEM Safety Manual delivered with the machine gives general safety information.
- The Compact Excavator Operating Training Course is available through your Bobcat dealer. This course is intended to provide rules and practices of correct operation of the Bobcat excavator. The course is available in English and Spanish versions.
- Service Safety Training Courses are available from your Bobcat dealer. They provide information for safe and correct service procedures.
- See the PUBLICATIONS AND TRAINING RESOURCES Page in this manual or your Bobcat dealer for Service and Parts Manuals, printed materials, videos, or training courses available. Also check the Bobcat web sites www.training.bobcat.com or www.bobcat.com

The dealer and owner / operator review the recommended uses of the product when delivered. If the owner / operator will be using the machine for a different application(s) he or she must ask the dealer for recommendations on the new use.



Call Before You Dig
Dial 811 (USA Only)
1-888-258-0808 (USA & Canada)

When you call, you will be directed to a location in your state / province, or city for information about buried lines (telephone, cable TV, water, sewer, gas, etc.).

SI EXC-0511

SAFETY INSTRUCTIONS (CONT'D)

Safe Operation Is The Operator's Responsibility

 Safety Alert Symbol
This symbol with a warning statement means: "Warning, be alert! Your safety is involved!" Carefully read the message that follows.



Operator must have instructions before operating the machine. Untrained operators can cause injury or death.

W-2001-0502



This notice identifies procedures which must be followed to avoid damage to the machine.

I-2019-0284



The signal word **DANGER** on the machine and in the manuals indicates a hazardous situation which, if not avoided, will result in death or serious injury.

D-1002-1107



The signal word **WARNING** on the machine and in the manuals indicates a potentially hazardous situation which, if not avoided, could result in death or serious injury.

W-2044-1107

The Bobcat excavator and attachment must be in good operating condition before use.

Check all of the items on the Bobcat Service Schedule Decal under the 8 - 10 hour column or as shown in the Operation & Maintenance Manual.

Safe Operation Needs A Qualified Operator

For an operator to be qualified, he or she must not use drugs or alcoholic drinks which impair alertness or coordination while working. An operator who is taking prescription drugs must get medical advice to determine if he or she can safely operate a machine.

A Qualified Operator Must Do The Following:

Understand the Written Instructions, Rules and Regulations

- The written instructions from Bobcat Company include the Delivery Report, Operation & Maintenance Manual, Operator's Handbook, Safety Manual and machine signs (decals).
- Check the rules and regulations at your location. The rules can include an employer's work safety requirements. Regulations can apply to local driving requirements or use of a Slow Moving Vehicle (SMV) emblem. Regulations can identify a hazard such as a utility line.

Have Training with Actual Operation

- Operator training must consist of a demonstration and verbal instruction. This training is given by your Bobcat dealer before the product is delivered.
- The new operator must start in an area without bystanders and use all the controls until he or she can operate the machine and attachment safely under all conditions of the work area. Always fasten seat belt before operating.
- Operator Training Courses are available from your Bobcat dealer in English and Spanish. They provide information for safe and efficient equipment operation. Safety videos are also available.
- Service Safety Training Courses are available from your Bobcat dealer. They provide information for safe and correct service procedures.

Know the Work Conditions

- Know the weight of the materials being handled. Avoid exceeding the Rated Lift Capacity of the machine. Material which is very dense will be heavier than the same volume of less dense material. Reduce the size of load if handling dense material.
- The operator must know any prohibited uses or work areas, for example, he or she needs to know about excessive slopes.
- Know the location of any underground lines. Call local utilities or the TOLL FREE phone number found in the *Before Operation* section of this manual.
- Wear tight fitting clothing. Always wear safety glasses when doing maintenance or service. Safety glasses, respiratory equipment, hearing protection or Special Applications Kits are required for some work. See your Bobcat dealer about Bobcat safety equipment for your model.

SI EXC-0511

SAFETY INSTRUCTIONS (CONT'D)

Avoid Silica Dust



Cutting or drilling concrete containing sand or rock containing quartz can result in exposure to silica dust. Do not exceed Permissible Exposure Limits (PEL) to silica dust as determined by OSHA or other job site Rules and Regulations. Use a respirator, water spray or other means to control dust. Silica dust can cause lung disease and is known to the state of California to cause cancer.

FIRE PREVENTION



Maintenance

The machine and some attachments have components that are at high temperatures under normal operating conditions. The primary source of high temperatures is the engine and exhaust system. The electrical system, if damaged or incorrectly maintained, can be a source of arcs or sparks.

Flammable debris (leaves, straw, etc.) must be removed regularly. If flammable debris is allowed to accumulate, it can cause a fire hazard. Clean often to avoid this accumulation. Flammable debris in the engine compartment is a potential fire hazard.

The operator's area, engine compartment and engine cooling system must be inspected every day and cleaned if necessary to prevent fire hazards and overheating.

All fuels, most lubricants and some coolant mixtures are flammable. Flammable fluids that are leaking or spilled onto hot surfaces or onto electrical components can cause a fire.

Operation

Do not use the machine where exhaust, arcs, sparks or hot components can contact flammable material, explosive dust or gases.

Electrical



Check all electrical wiring and connections for damage. Keep the battery terminals clean and tight. Repair or replace any damaged part or wires that are loose or frayed.

Battery gas can explode and cause serious injury. Use the procedure in the Operation & Maintenance Manual for connecting the battery and for jump starting. Do not jump start or charge a frozen or damaged battery. Keep any open flames or sparks away from batteries. Do not smoke in battery charging area.

SI EXC-0511

FIRE PREVENTION (CONT'D)

Hydraulic System

Check hydraulic tubes, hoses and fittings for damage and leakage. Never use open flame or bare skin to check for leaks. Hydraulic tubes and hoses must be properly routed and have adequate support and secure clamps. Tighten or replace any parts that show leakage.

Always clean fluid spills. Do not use gasoline or diesel fuel for cleaning parts. Use commercial nonflammable solvents.

Fueling



Stop the engine and let it cool before adding fuel. No smoking! Do not refuel a machine near open flames or sparks. Fill the fuel tank outdoors.

Starting

Do not use ether or starting fluids on any engine that has glow plugs or air intake heater. These starting aids can cause explosion and injure you or bystanders.

Use the procedure in the Operation & Maintenance Manual for connecting the battery and for jump starting.

Spark Arrester Exhaust System

The spark arrester exhaust system is designed to control the emission of hot particles from the engine and exhaust system, but the muffler and the exhaust gases are still hot.

Check the spark arrester exhaust system regularly to make sure it is maintained and working properly. Use the procedure in the Operation & Maintenance Manual for cleaning the spark arrester muffler (if equipped).

Welding And Grinding

Always clean the machine and attachment, disconnect the battery, and disconnect the wiring from the Bobcat controllers before welding. Cover rubber hoses, battery and all other flammable parts. Keep a fire extinguisher near the machine when welding.

Have good ventilation when grinding or welding painted parts. Wear dust mask when grinding painted parts. Toxic dust or gas can be produced.

Dust generated from repairing nonmetallic parts such as hoods, fenders or covers can be flammable or explosive. Repair such components in a well ventilated area away from open flames or sparks.

Fire Extinguishers

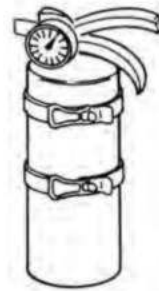

Know where fire extinguishers and first aid kits are located and how to use them. Inspect the fire extinguisher and service the fire extinguisher regularly. Obey the recommendations on the instructions plate.

PUBLICATIONS AND TRAINING RESOURCES

The following publications are also available for your Bobcat excavator. You can order them from your Bobcat dealer.

For the latest information on Bobcat products and the Bobcat Company, visit our web site at www.bobcat.com; you can also order Operator and Service Training materials online through www.bobcatstore.com



OPERATION & MAINTENANCE MANUAL

6990096

- Complete instructions on the correct operation and the routine maintenance of the Bobcat excavator.

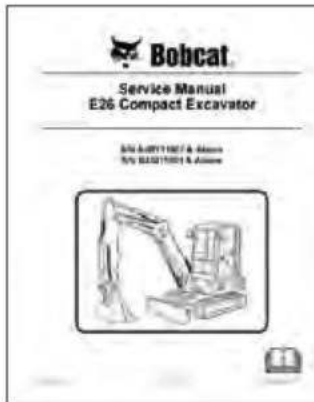

SERVICE MANUAL

6990097

- Complete maintenance instructions for your Bobcat excavator.

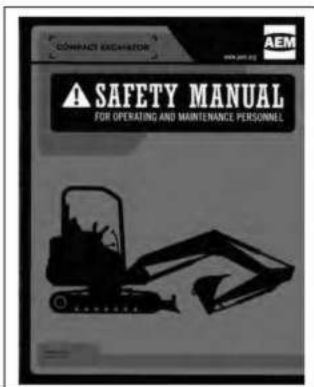

SAFETY MANUAL

6901951

- Provide basic safety procedures and warnings for your Bobcat excavator



OPERATOR'S HANDBOOK

6987271

Gives basic operation instructions and safety warnings



COMPACT EXCAVATOR OPERATOR TRAINING COURSE

6903186

Introduces operator to step-by-step basics of compact excavator operation. Also available in Spanish P/N 6903228



EXCAVATOR SERVICE SAFETY COURSE

6900916

Introduces Service Technicians to step-by-step basics of proper and safe excavator maintenance and servicing procedures



OPERATOR SAFETY DVD

6904762

Provides basic safety instructions contained in all Bobcat Safety Videos in both English and Spanish.



EXCAVATOR SAFETY VIDEO

(Mobile device with quick response code application required)

Scan the code above to watch the excavator safety video or view at www.training.bobcat.com.

Dealer Copy -- Not for Resale

MACHINE SIGNS (DECALS)

Follow the instructions on all the Machine Signs (Decals) that are on the excavator. Replace any damaged machine signs and be sure they are in the correct locations. Machine signs are available from your Bobcat excavator dealer.

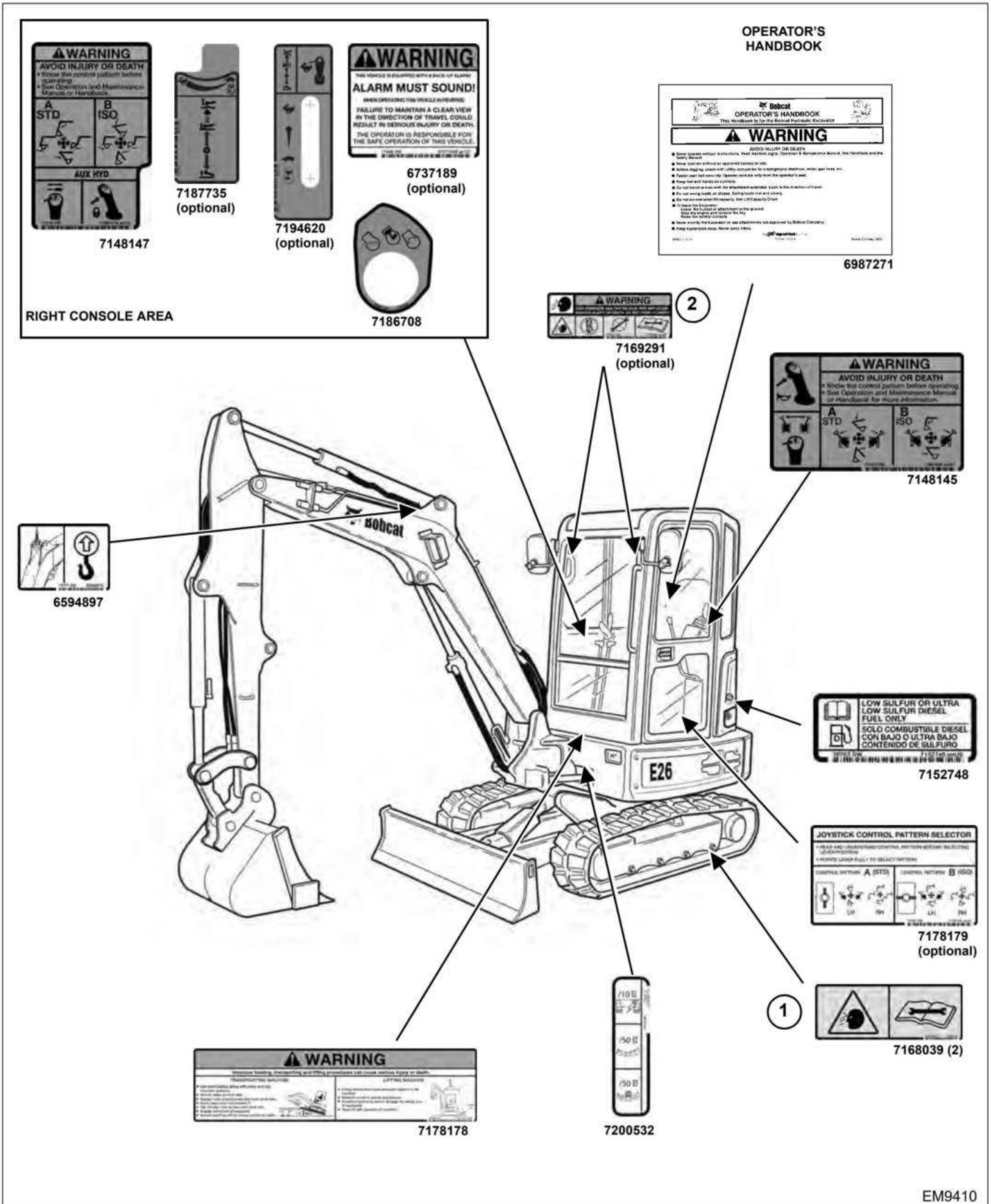

Dealer Copy -- Not for Resale

EM9410

MACHINE SIGNS (DECALS) (CONT'D)

No-Text Safety Signs

Safety signs are used to alert the equipment operator or maintenance person to hazards that can be encountered in the use and maintenance of the equipment. The location and description of the safety signs are detailed in this section. Please become familiarized with all safety signs installed on the excavator.

Vertical Configuration

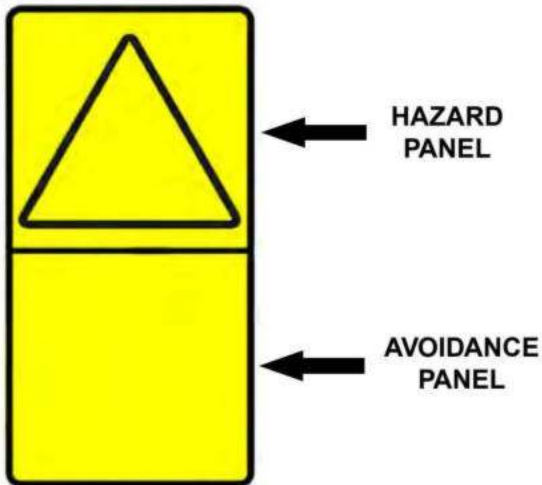

Horizontal Configuration

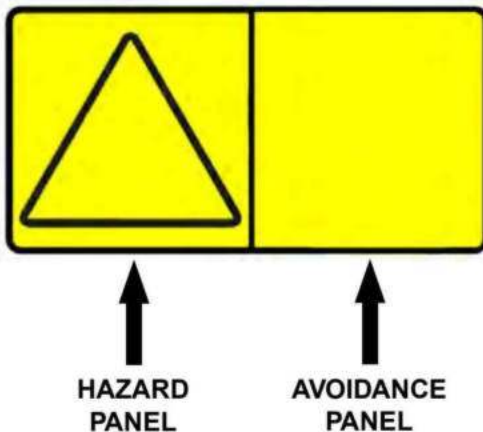

The format consists of the hazard panel(s) and the avoidance panel(s):

Hazard panels depict a potential hazard enclosed in a safety alert triangle.

Avoidance panels depict actions required to avoid the hazards.

A safety sign can contain more than one hazard panel and more than one avoidance panel.

NOTE: See the numbered MACHINE SIGNS (DECALS) on Page 20 and Machine Signs (Decals) (Cont'd) on Page 21 for the machine location of each corresponding numbered no-text decals as shown below.

1. Thrown Or Flying Objects (7168039)

This safety sign is located on the outside of both tracks.

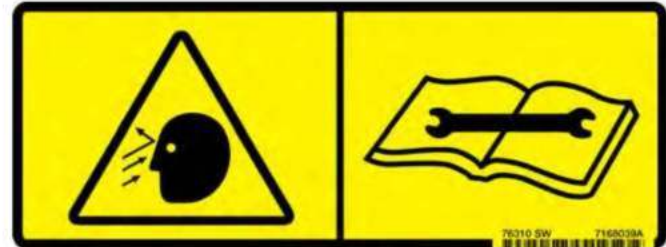

High pressure grease can cause serious injury. Do not loosen grease fitting. Do not loosen bleed fitting more than 1 - 1/2 turns.

Read and understand the Operation & Maintenance Manual for more information.

W-2516-0110

2. High Pressure Gas (7169291)

This safety sign is located on the gas spring component(s) supporting the tailgate and also the front window (if equipped).



HIGH PRESSURE GAS CAN RELEASE ROD AND CAUSE SERIOUS INJURY OR DEATH

- Do not open cylinder.
- See Service Manual for more information.

W-2756-0908

OPERATING INSTRUCTIONS

INSTRUMENTS AND CONSOLES	27
Cab Interior Light	27
Left Console	27
Right Console	28
Indicator Icons	29
STD / ISO Selector Valve	30
Raising And Lowering The Console	30
Two-Speed Travel	31
Auto Shift Drive Motors	31
Auto Idle Feature	31
OPERATOR CANOPY (ROPS / TOPS)	32
Description	32
OPERATOR CAB (ROPS / TOPS)	32
Description	32
Cab Door	33
Front Window	34
Front Window	35
Front Wiper	36
Window Washer Reservoir	36
Right Side Window	37
Heating, Ventilation And Air Conditioning Ducting	38
EMERGENCY EXIT	39
Right Side Rear Window	39
Front Window	39
MOTION ALARM SYSTEM	40
Operation	40
TRAVEL CONTROLS	41
Forward And Reverse Travel	41
Turning	41
HYDRAULIC CONTROLS	43
Description	43
STANDARD Control Pattern	43
ISO Control Pattern	44
Quick Couplers	45
Auxiliary Hydraulics	46
Relieve Hydraulic Pressure (Excavator And Attachment)	46
Secondary Auxiliary Hydraulics	47
Relieve Hydraulic Pressure (Excavator And Attachment)	47
Direct To Tank Valve	48
BLADE CONTROL LEVER	49
Raising And Lowering Blade	49

ENGINE SPEED CONTROL	49
Setting Engine Speed (RPM)	49
BOOM SWING	50
Operation	50
DAILY INSPECTION	51
Daily Inspection And Maintenance	51
PRE-STARTING PROCEDURE	52
Operation & Maintenance Manual And Operator's Handbook Locations	52
Entering The Excavator	52
Seat Adjustment	53
Seat Belt	53
Control Console	54
Mirror Adjustment	54
STARTING THE ENGINE	55
Key Switch	55
Keyless	56
Cold Temperature Starting	57
Warming The Hydraulic System	58
STOPPING THE ENGINE AND LEAVING THE EXCAVATOR	59
Procedure	59
ATTACHMENTS	60
Installing And Removing The Attachment (Pin-On X-Change)	60
Installing And Removing The Attachment (Pin-On Attachment)	66
OPERATING PROCEDURE	67
Inspect The Work Area	67
Basic Operating Instructions	67
Lowering The Work Equipment (Engine STOPPED)	67
Object Handling	68
Using The Clamp	69
Excavating	70
Boom Swing	72
Backfilling	73
Driving The Excavator	73
Operating On Slopes	74
Operating In Water	76
Avoiding Track Damage	77
TOWING THE EXCAVATOR	78
Procedure	78
LIFTING THE EXCAVATOR	79
Procedure	79

TRANSPORTING THE EXCAVATOR ON A TRAILER80
Loading And Unloading80
Fastening80

Dealer Copy -- Not for Resale



Bobcat®

Dealer Copy -- Not for Resale

INSTRUMENTS AND CONSOLES

Cab Interior Light

Interior light is equipped on excavators with cab.

Figure 7

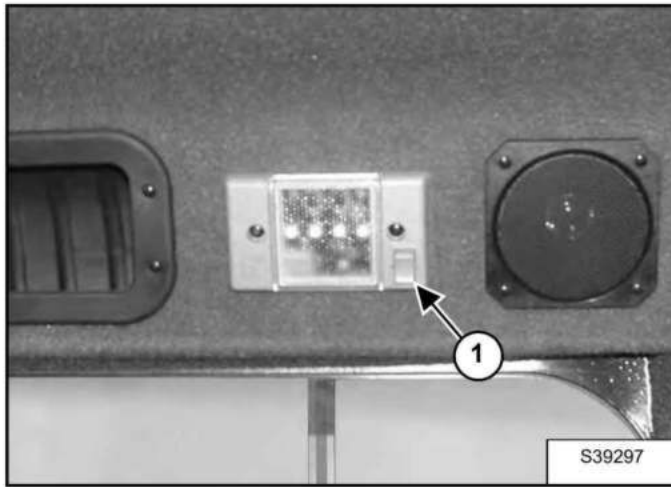

Press the top of the switch (Item 1) [Figure 7] to turn the light ON. Press the bottom of the switch to turn OFF.

Left Console

Figure 8

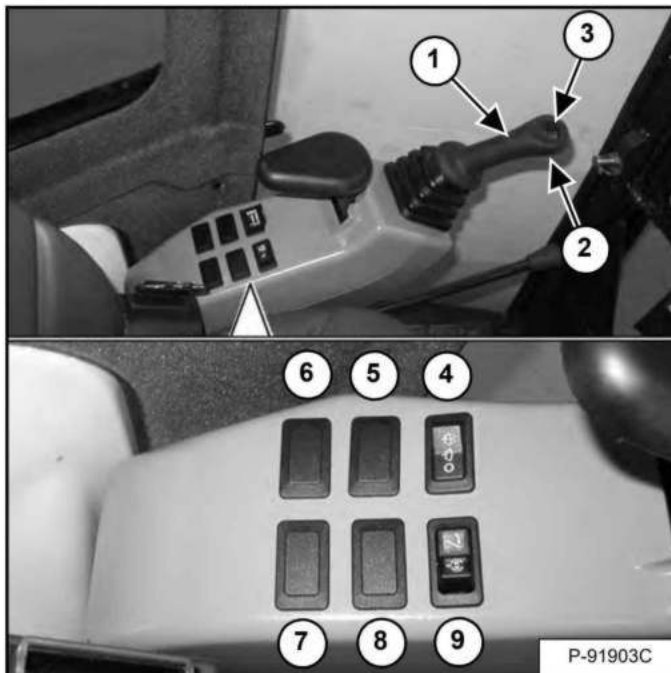

Left Console [Figure 8]

REF. NO.	DESCRIPTION	FUNCTION / OPERATION
1	Left Joystick	(See HYDRAULIC CONTROLS on Page 43.)
2	Horn	Press the switch on the bottom of the left joystick to sound horn.
3	Boom Swing Switch / Secondary Auxiliary Hydraulics (If equipped)	Move the switch to the left to swing the boom to the left. Move the switch to the right to swing the boom to the right. (See Secondary Auxiliary Hydraulics and Boom Swing in this manual.)
4	Wiper / Washer Switch (If equipped)	Press the switch to the left to turn wiper ON. Press and hold switch to the left to activate window washer. Press the switch to the right to turn wiper OFF.
5	Not Used	---
6	Beacon / Strobe Light (If equipped)	Press switch to the left to turn ON the beacon / Strobe light. Press the switch to the right to turn OFF.
7	Not Used	---
8	Not Used	---
9	Boom Swing Switch / Secondary Auxiliary Hydraulics	Move the switch to the right to activate the secondary auxiliary hydraulics. Move the switch to the left for boom swing function. (See Secondary Auxiliary Hydraulics and Boom Swing in this manual.)

Dealer Copy -- Not for Resale

INSTRUMENTS AND CONSOLES (CONT'D)

Right Console

Figure 9

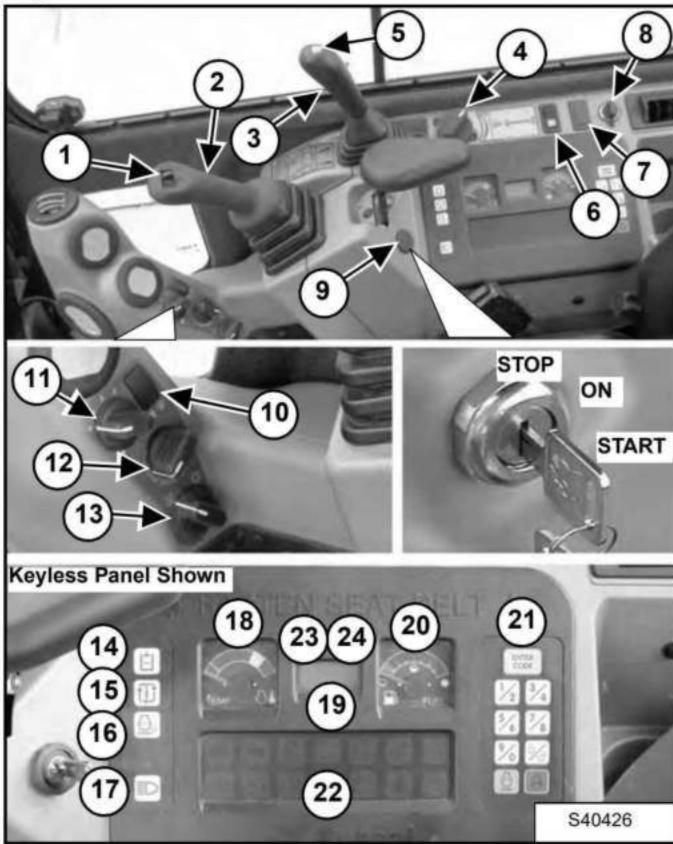

Right Console [Figure 9]

REF.	DESCRIPTION	FUNCTION / OPERATION
1	Right Joystick	(See HYDRAULIC CONTROLS in this manual.)
2	Auxiliary Hydraulic Switch	Controls the fluid flow to the auxiliary quick couplers (attachment). (See Auxiliary Hydraulics in this manual.)
3	Blade Control Lever	Controls raising and lowering the blade. Pushed all the way forward puts blade in float position. (See BLADE CONTROL LEVER in this manual.)
4	Engine Speed Control Dial Gauge	Controls rpm of the engine. (See ENGINE SPEED CONTROL in this manual.)
5	Two Speed Button	Engages and disengages high range travel speed. (See Two-Speed Travel in this manual.)
6	Motion Alarm Cancel Switch	This switch temporarily disables the motion alarm. (See MOTION ALARM SYSTEM in this manual.)
7	Not Used	---
8	Auxiliary Power Outlet	12 volt receptacle for accessories.

REF.	DESCRIPTION	FUNCTION / OPERATION
9	Key Switch (STANDARD Panel Only)	Always perform the PRE-STARTING PROCEDURE. (See PRE-STARTING PROCEDURE in this manual), before starting the engine. (See STARTING THE ENGINE in this manual).
10	Air Conditioning Switch (If equipped)	Press top of switch to turn air conditioner ON (light in switch will be ON), Press bottom of switch to turn OFF.
11	Fan Motor Switch (If equipped)	Turn clockwise to increase fan speed; counterclockwise to decrease.
12	Temperature Control (If equipped)	Turn clockwise to increase temperature; counterclockwise to decrease.
13	Recirculation / Fresh Air Control	Turn clockwise for fresh air; counterclockwise for recirculation. (Use recirculation mode for increased heating and cooling efficiency.)
14	Auxiliary Hydraulic Button	Activates and deactivates auxiliary hydraulic function. (See Auxiliary Hydraulics in this manual).
15	Information	Cycles through (after each button press): hours, job clock, engine rpm, Selectable Auxiliary Hydraulic Flow (when activated); in the data display, Item 19.) (See Password Lockout Feature and Maintenance Clock in this manual).
16	Auto Idle Feature	Press once to turn auto idle feature ON, press a second time to turn OFF. (See Auto Idle Feature in this manual).
17	Lights	Press once to turn lights ON; press again to turn lights OFF.
18	Temperature	Shows the engine coolant temperature.
19	Data Display Screen	The data display screen shows the Hourmeter during normal operation of the excavator. When preheat is activated, the display screen will show the remaining preheat time. Can also be used to display Job Clock, Engine rpm, and Selectable Auxiliary Hydraulic Flow. (See Job Clock and Maintenance Clock in this manual).
20	Fuel Gauge	Shows the amount of fuel in the tank.
21	Keyless (OPTIONAL)	(Always perform the PRE-STARTING PROCEDURE, (See PRE-STARTING PROCEDURE in this manual), before starting the engine. (See STARTING THE ENGINE in this manual).
22	Indicator Icons	(See Indicator Icons in this manual).
23	Job	On when job clock is activated.
24	Rpm	On when engine rpm is activated.

NOTE: Always turn key switch and all accessories to OFF position when the engine is stopped, the battery will discharge if the key is left ON. Audible alarm will sound if the key is in the ON position with the engine stopped.

INSTRUMENTS AND CONSOLES (CONT'D)

Indicator Icons

Figure 10

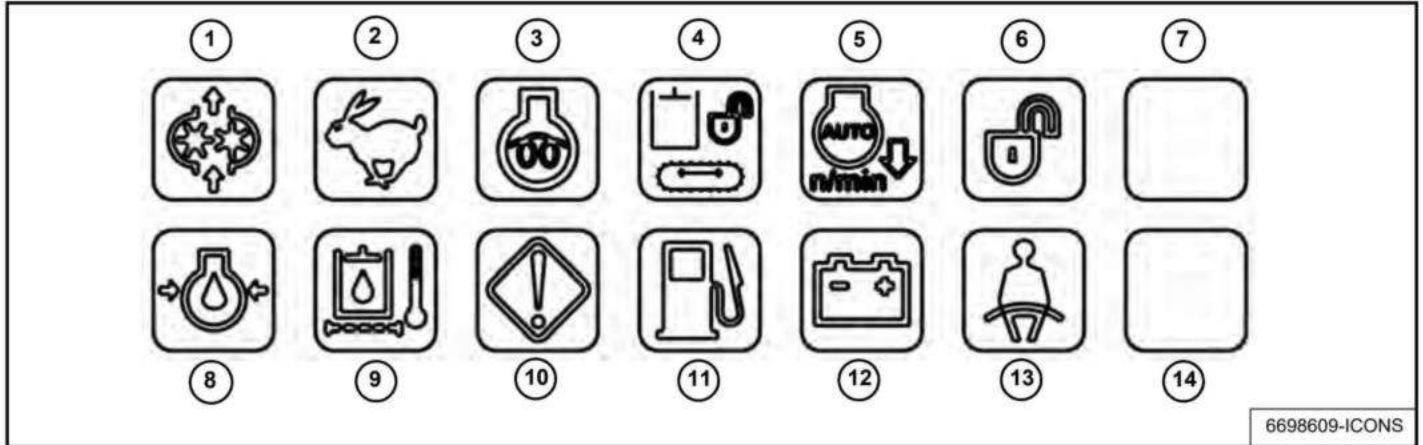

The right console contains the instrument panel with Indicator Icons [Figure 10].

NOTE: If a Warning Icon (Icons 8, 9, 10 and 12) is illuminated or flashes, appropriate action is needed to avoid potential machine damage. Service the machine as soon as possible when conditions are present.

REF. NO.	INDICATOR ICONS		
	<i>When Indicator Icon Is Illuminated</i>	<i>When Indicator Icon Is OFF</i>	<i>When Indicator Icon Is Flashing</i>
1	Auxiliary Hydraulics Engaged	Auxiliary Hydraulics Disengaged	(See Service Codes List on Page 131.)
2	High Range Engaged	Low Range Engaged	(See Service Codes List on Page 131.)
3	Glow Plugs Energized	Glow Plugs OFF	(See Service Codes List on Page 131.)
4	Hydraulic Traction Drive Activated	Hydraulic Traction Drive Deactivated	(See Service Codes List on Page 131.)
5	Auto Idle System Engaged	Auto Idle System Disengaged	(See Service Codes List on Page 131.)
6	Keypad Unlocked	Keypad Locked	-----
7	Future Use		
8	Low Engine Oil Pressure	Engine Oil Pressure in operating range	Extremely Low Engine Oil Pressure, Engine will shut down in 10 seconds, (See Service Codes List on Page 131.)
9	Plugged Hydraulic Filter or High Hydraulic Oil Temperature	Hydraulic Filter and Oil in operating range.	Extremely High Hydraulic Oil Temperature, Engine will shut down in 10 seconds, (See Service Codes List on Page 131.)
10	General Warning	All system in operating range	Extremely High Coolant Temperature or Extremely High Engine rpm, Engine will shut down in 10 seconds, (See Service Codes List on Page 131.)
11	Low Fuel Level	Fuel level in operating range	----
12	Extremely Low Battery Voltage, Engine will shut down in 10 seconds, (See Service Codes List on Page 131.)	Battery Voltage in operating range	High or Low Battery Voltage
13	Fasten Seat Belt Reminder - Light stays on for 45 seconds to remind operator to fasten seat belt.	----	----
14	Future Use		

Dealer Copy -- Not for Resale

INSTRUMENTS AND CONTROLS (CONT'D)

STD / ISO Selector Valve

The STD / ISO selector valve (if equipped) is located below the operator's seat, inside the tool box.

Figure 11

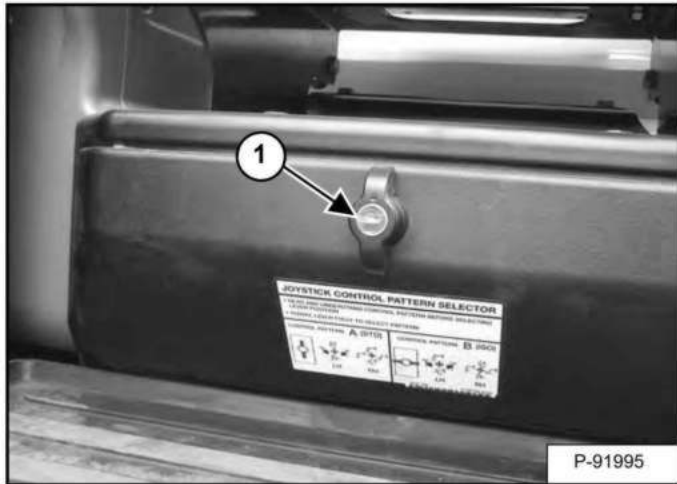

From below the operator's seat, open the tool box cover (Item 1) [Figure 11].

Figure 12

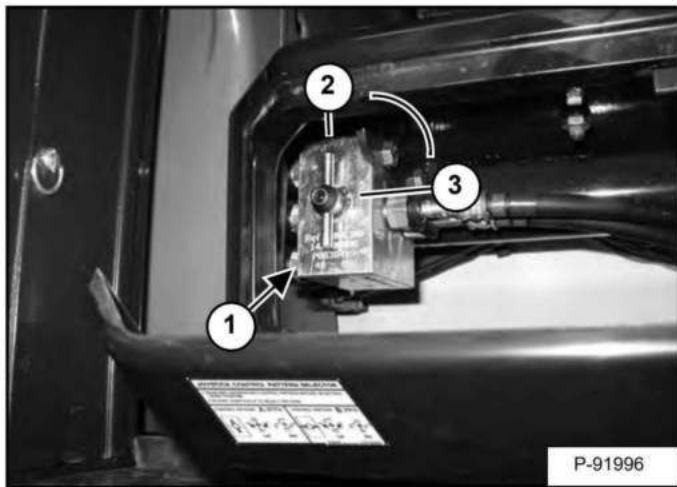

The joystick hydraulic function can be switched from Standard control pattern to ISO control pattern.

Rotate the lever (Item 1) counterclockwise (Item 2) to select STANDARD Control Pattern. Rotate the lever clockwise (Item 3) to select ISO Control Pattern [Figure 12].

Raising And Lowering The Console

Raise the console before exiting the cab.

Figure 13



Pull up on the release handle [Figure 13]. The lift spring will assist in raising the console.

Lower the console before operating the excavator.

Push down on the console [Figure 13] until the latch is engaged.

NOTE: When the console is raised, the hydraulic and traction system functions are locked and will not operate.

If the engine stops, the boom / bucket (attachments) can be lowered to the ground using hydraulic pressure in the accumulator.

The control console must be in the locked down position, and the key switch in the ON position.

INSTRUMENTS AND CONTROLS (CONT'D)

Two-Speed Travel

Figure 14

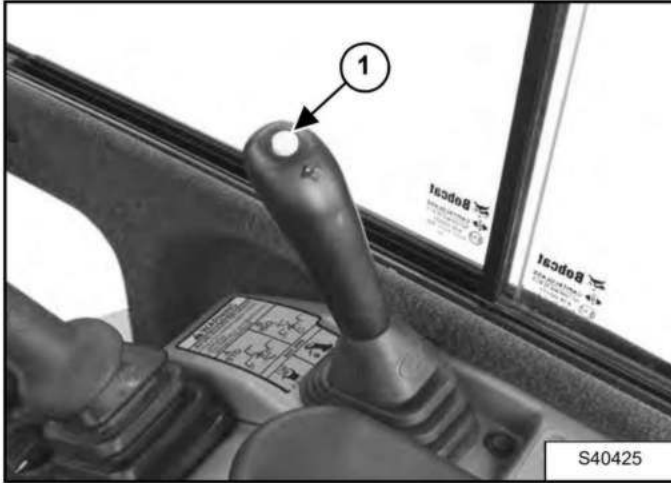

Press the button (Item 1) [Figure 14] to engage the High Range. Press a second time to disengage.

Figure 15

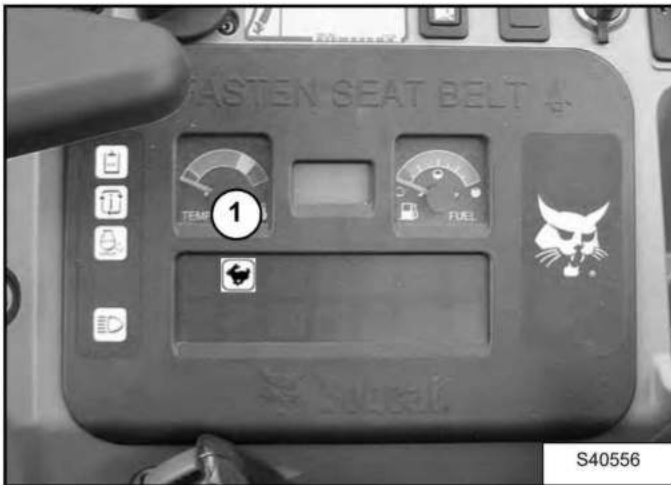

When High Range is engaged, the two speed travel icon (Item 1) [Figure 15] will illuminate.

Press the button (Item 1) [Figure 14] again to disengage.

Auto Shift Drive Motors

The travel motors are equipped with an auto shift feature that senses hydraulic pressure. When in high range, the travel motors will automatically shift to low range when more torque is required and return to high range when hydraulic pressure decreases.

NOTE: Always set the travel speed to low range when loading or unloading the excavator onto a transport vehicle.

Auto Idle Feature

Figure 16



The auto idle feature (when engaged) will reduce the engine speed to low idle when the control levers (joystick, blade, travel, etc.) are in neutral and not used for approximately 4 seconds. The engine rpm will return to the set position as soon as any control lever is activated.

The automatic idle switch (Item 1) [Figure 16] is used to engage or disengage the automatic idle feature.

Press the switch (Item 1) once to engage automatic idle and the icon (Item 2) will illuminate. Press the switch (Item 1) a second time to disengage automatic idle, the icon (Item 2) [Figure 16] will be OFF.

NOTE: Always disengage the auto idle feature when loading or unloading the excavator onto a transport vehicle.

Dealer Copy -- Not for Resale

OPERATOR CANOPY (ROPS / TOPS)

Description

The Bobcat excavator has an operator canopy (ROPS / TOPS) as standard equipment to protect the operator if the excavator is tipped over. The seat belt must be worn for ROPS / TOPS protection.

Check the ROPS / TOPS canopy, mounting, and hardware for damage. Never modify the ROPS / TOPS canopy. Replace the canopy and hardware if damaged. See your Bobcat dealer for parts.

ROPS / TOPS - Roll Over Protective Structure and Tip Over Protective Structure per ISO 12117.



Never modify operator cab by welding, grinding, drilling holes or adding attachments unless instructed to do so by Bobcat Company. Changes to the cab can cause loss of operator protection from rollover and falling objects, and result in injury or death.

W-2069-0200

OPERATOR CAB (ROPS / TOPS)

Description

The Bobcat excavator has an optional operator cab (ROPS / TOPS) as standard equipment to protect the operator if the excavator is tipped over. The seat belt must be worn for ROPS / TOPS protection.

Check the ROPS / TOPS cab, mounting, and hardware for damage. Never modify the ROPS / TOPS cab. Replace the cab and hardware if damaged. See your Bobcat dealer for parts.

ROPS / TOPS - Roll Over Protective Structure and Tip Over Protective Structure per ISO 12117.



Never modify operator cab by welding, grinding, drilling holes or adding attachments unless instructed to do so by Bobcat Company. Changes to the cab can cause loss of operator protection from rollover and falling objects, and result in injury or death.

W-2069-0200

OPERATOR CAB (ROPS / TOPS) (CONT'D)

Cab Door

Figure 17

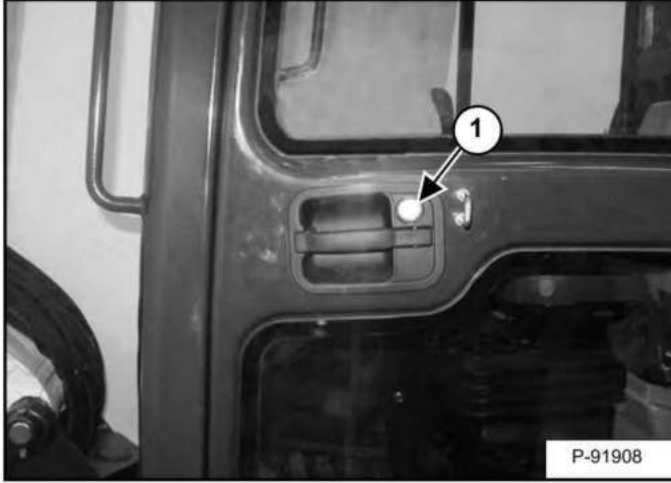

The cab door can be locked (Item 1) [Figure 17] with the same key as the starter switch.

Figure 18

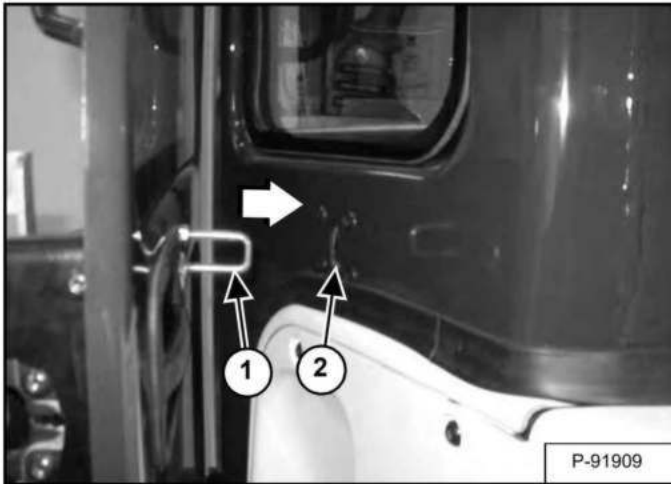

Push the door all the way open until the latch post (Item 1) engages in the latch (Item 2) [Figure 18] to hold the door in the open position.

Figure 19

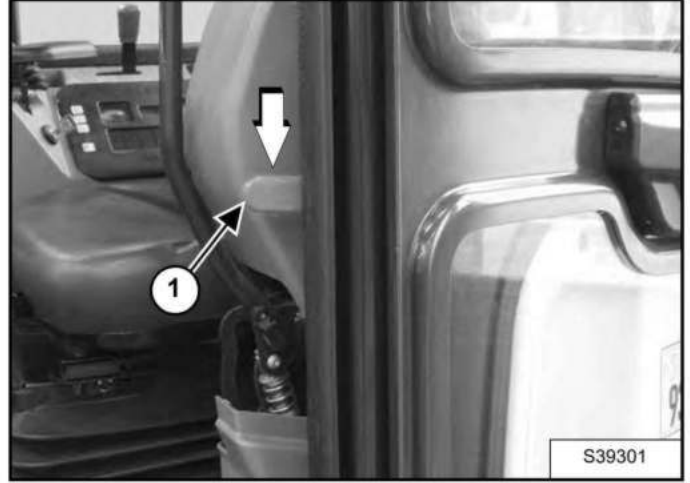

When the door is in the open position, push down on the latch (Item 1) [Figure 19] and close the door.

Figure 20

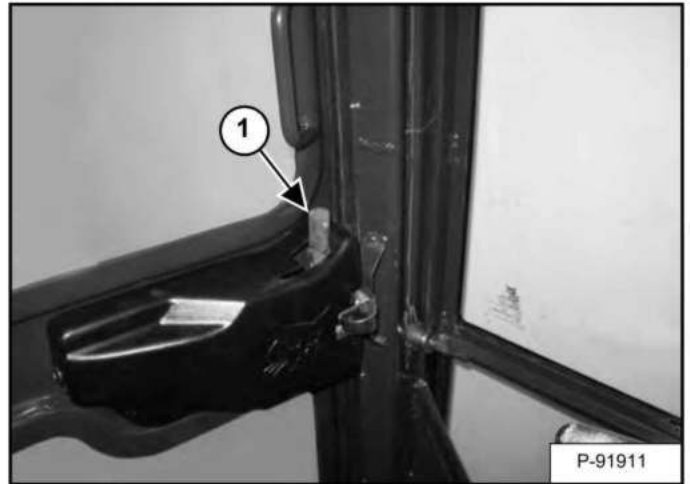

From inside the cab, open the door using handle (Item 1) [Figure 20].

Dealer Copy -- Not for Resale

OPERATOR CAB (ROPS / TOPS) (CONT'D)

Front Window

Opening The Front Window (Early Models)

Figure 21

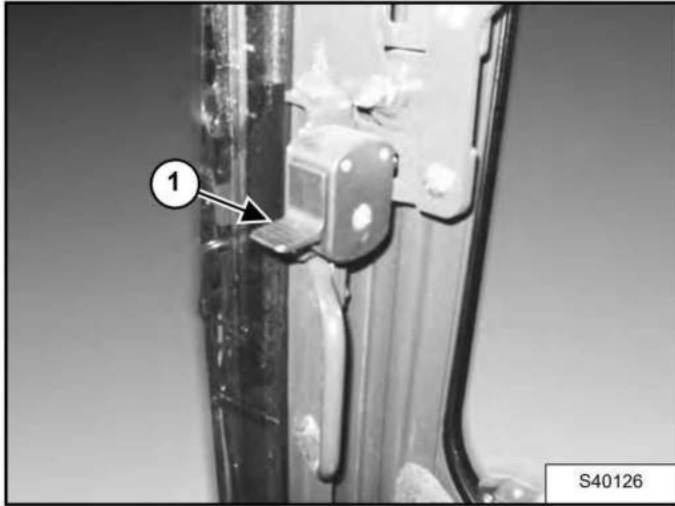

Press the top window latch (Item 1) [Figure 21] (both sides).

Figure 22

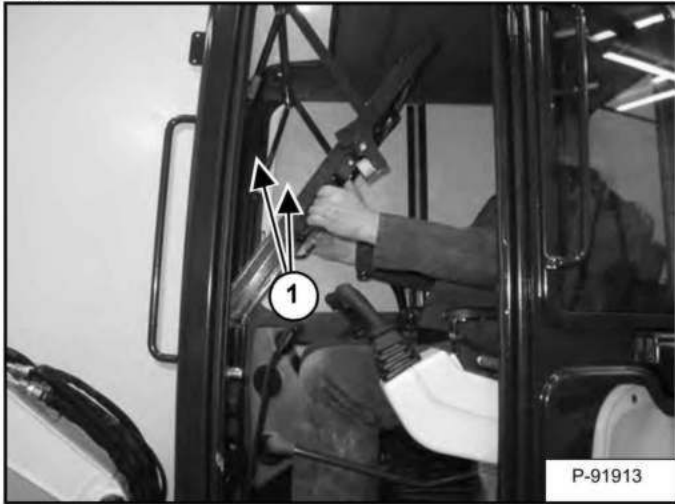

Use both window grab handles (Item 1) [Figure 22] to pull the top of the window in.

Continue moving the window in and up over the operator's head until the window is fully raised.

Figure 23

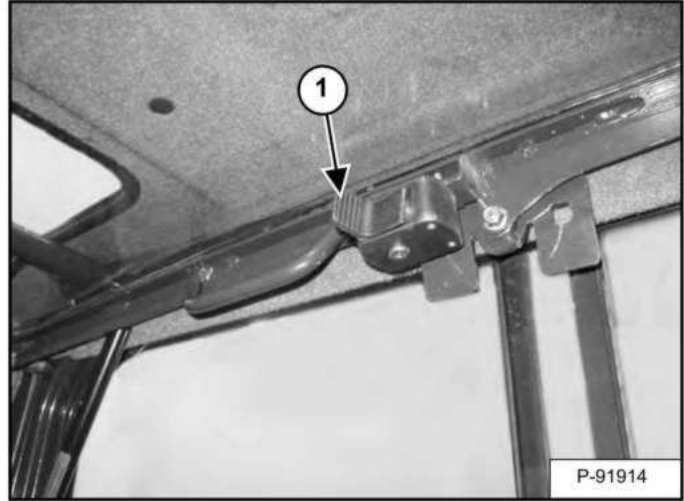

When the window is fully raised, the latch (Item 1) [Figure 23] (both sides) will close on the bracket in the latched position.

Pull down slightly on the window to make sure it is fully latched.

Closing The Front Window (Early Models)

Support the window while releasing the window latch (Item 1) [Figure 23] (both sides).

Use both window grab handles (Item 1) [Figure 22] to pull the window down fully.

Press the top of the window in until the latch (Item 1) [Figure 21] locks into the latched position (both sides).

Pull inward slightly on the window to make sure it is fully latched in the closed position.

OPERATOR CAB (ROPS / TOPS) (CONT'D)

Front Window

Opening The Front Window (Later Models)

Figure 24

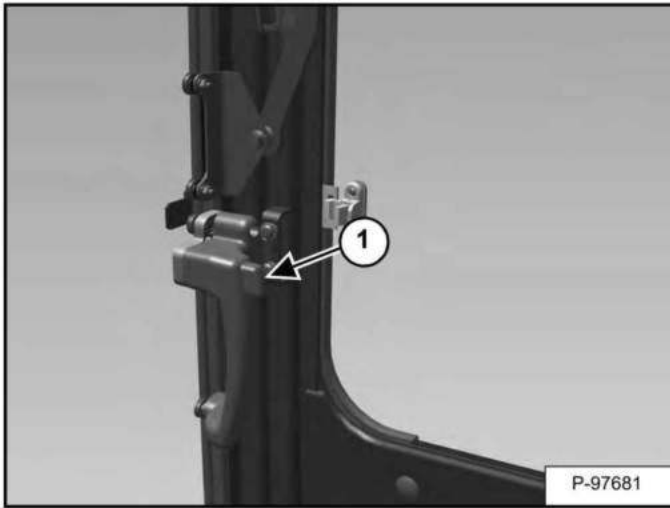

Press the window latch button (Item 1) [Figure 24] (both sides).

Figure 25



Use both window grab handles (Item 1) [Figure 25] to pull the top of the window in.

Continue moving the window in and up over the operator's head until the window is fully raised.

Figure 26

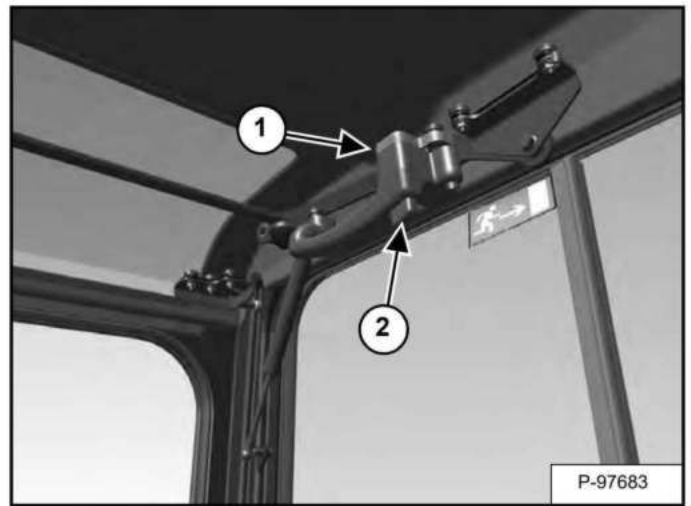

When the window is fully raised, the latch (Item 1) [Figure 26] (both sides) will close on the bracket in the latched position.

Pull down and forward slightly on the window to make sure it is fully latched.

Closing The Front Window (Later Models)

Use both window grab handles to support the window while pressing the window latch button (Item 2) [Figure 26] (both sides).

Use both window grab handles (Item 1) [Figure 25] to pull the window down fully.

Press the top of the window in until the latch locks into the latched position (both sides) [Figure 24].

Pull inward and upward slightly on the window to make sure it is fully latched in the closed position.

Dealer Copy -- Not for Resale

OPERATOR CAB (ROPS / TOPS) (CONT'D)

Front Wiper

Figure 27



The front window is equipped with a wiper (Item 1) [Figure 27] and washer.

Window Washer Reservoir

Figure 28

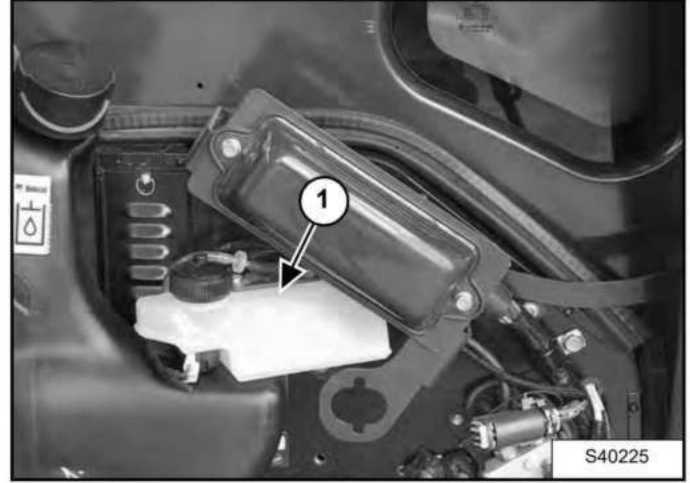

The window washer reservoir (Item 1) [Figure 28] is located under the right side cover.

OPERATOR CAB (ROPS / TOPS) (CONT'D)

Right Side Window

Opening The Right Rear Window

Figure 29

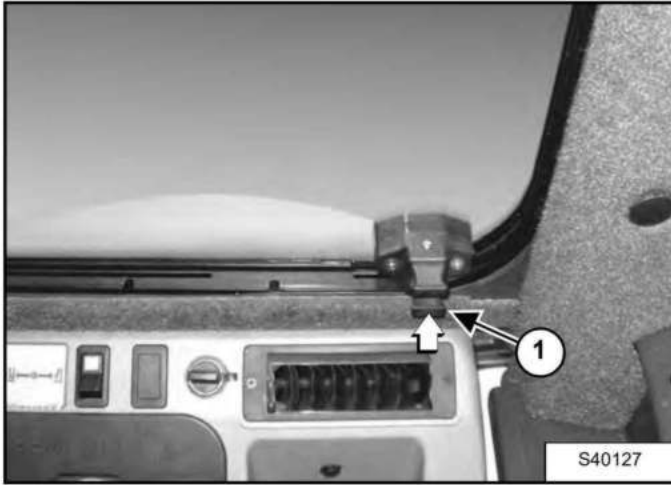

Pull up on the bottom latch (Item 1) [Figure 29].

Figure 30

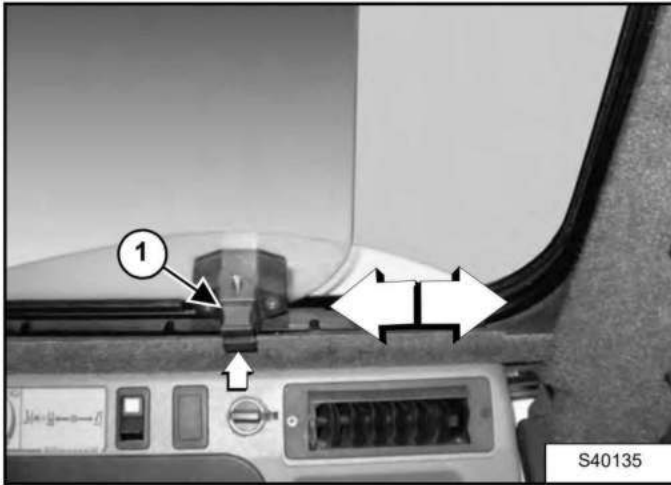

Pull the latch (Item 1) [Figure 30] forward to open the window until the desired stop. Release the bottom latch and snap the lock in place.

Closing The Right Rear Window

Pull up on the bottom latch (Item 1) [Figure 29] and push the latch back to close the window.

Opening The Right Front Window

Figure 31

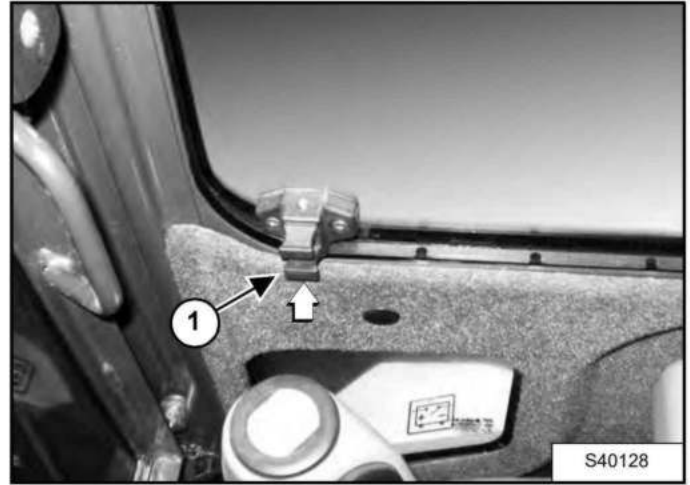

Pull up on the bottom latch (Item 1) [Figure 31] located at the front of the front window.

Figure 32

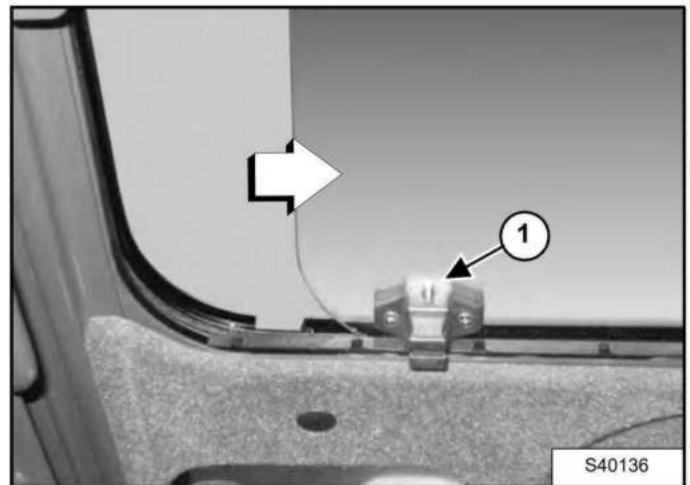

Pull the latch (Item 1) [Figure 32] forward to open the window until the desired stop. Release the bottom latch and snap the lock in place.

Closing The Right Front Window

Pull up on the bottom latch (Item 1) [Figure 31] and push the latch back to close the window.

Dealer Copy -- Not for Resale

OPERATOR CAB (ROPS / TOPS) (CONT'D)

Heating, Ventilation And Air Conditioning Ducting

Figure 33

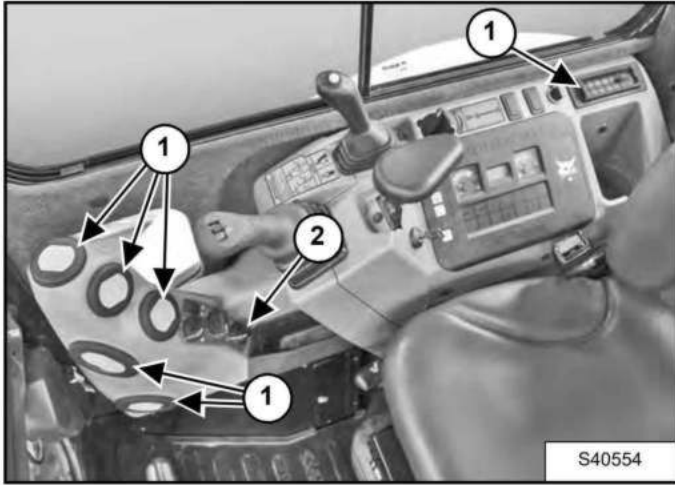

The HVAC louvers (Item 1) **[Figure 33]** can be positioned as needed to direct the air flow to various areas in the cab.

*Operating Tip: To increase heating or cooling efficiency, move the Recirculation / Fresh Air Control knob (Item 2) **[Figure 33]** to the recirculation position. This will allow the air to recirculate through the HVAC system and improve temperature control. If left in the fresh air position, the HVAC system will also need to heat or cool the ambient air that is drawn in from the outside, slowing and / or reducing the temperature change inside the cab.*

EMERGENCY EXIT

The door, the right side rear window and the front window provide exits.

Right Side Rear Window

Figure 34



Exit through the window [Figure 34].

Front Window

Figure 35



Open the front window and exit [Figure 35].

NOTE: If the excavator has a Special Applications Kit installed, the front window is NOT an emergency exit.

Dealer Copy -- Not for Resale

MOTION ALARM SYSTEM

Operation

Figure 36



This excavator can be equipped with a motion alarm system. The motion alarm is located inside the rear (Item 1) [Figure 36] of the excavator.

Figure 37

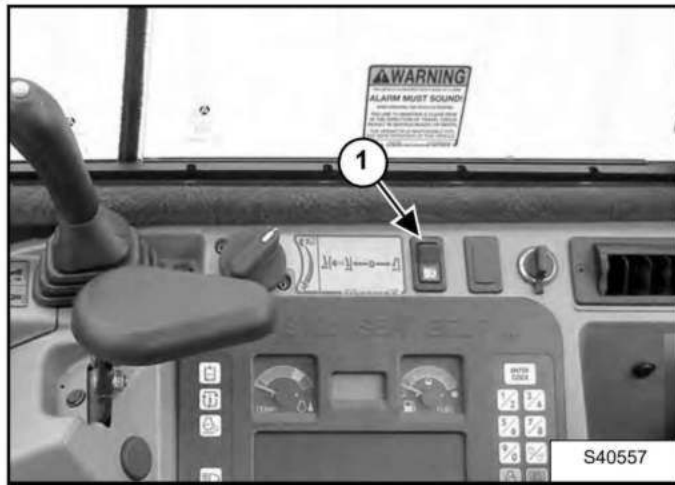

The motion alarm can be temporarily disabled by pressing the motion alarm switch (Item 1) [Figure 37] while the machine is moving. As soon as the travel levers are returned to the neutral position, the motion alarm will be enabled.

WARNING

This machine is equipped with a motion alarm.
ALARM MUST SOUND!
when operating forward or backward.

Failure to maintain a clear view in the direction of travel could result in serious injury or death.

The operator is responsible for the safe operation of this machine.

W-2786-0309

The motion alarm will sound when the operator moves the travel control levers (Item 1) [Figure 38] in either the forward or reverse direction.

If alarm does not sound or for adjustment instructions, see inspection and maintenance instructions for the motion alarm system in the preventive maintenance section of this manual. (See MOTION ALARM SYSTEM on Page 90.)

TRAVEL CONTROLS

Forward And Reverse Travel

NOTE: The following procedures describe forward, reverse, left and right as seated in the operator's seat.

Figure 38

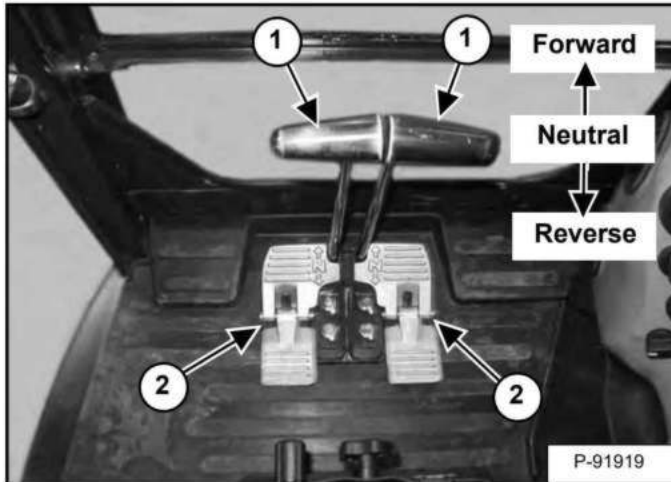

Put the blade so that it is at the front of the machine (as you sit in the operator's seat). Slowly move both steering levers* (Item 1) [Figure 38] forward for forward travel; backward for reverse travel.

* Travel can also be controlled with foot pedals (Item 2) [Figure 38]. Pivot the heel of the pedals forward for additional space on the floor.

WARNING

AVOID INJURY OR DEATH

- Check the blade location before traveling. When the blade is to the rear, operate the steering levers/foot pedals in the opposite direction to when the blade is in the front.
- Move the steering levers/foot pedals slowly. Abrupt lever motion will cause the machine to jerk.

W-2235-0396

Turning

Right Turn

Figure 39

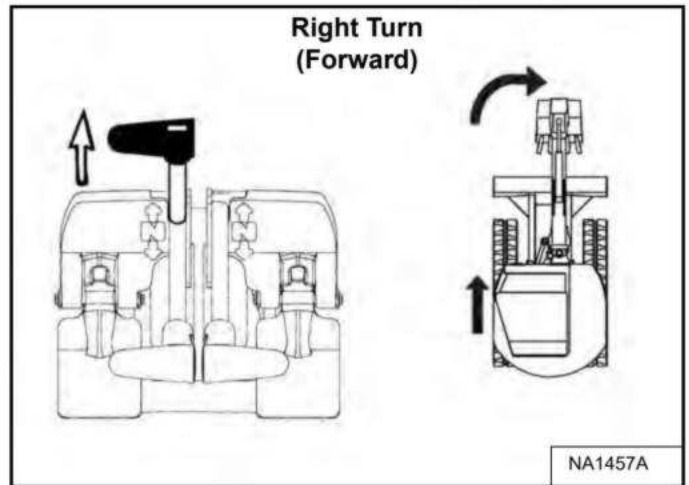

Push the left steering lever forward to turn right [Figure 39] while traveling forward.

Figure 40

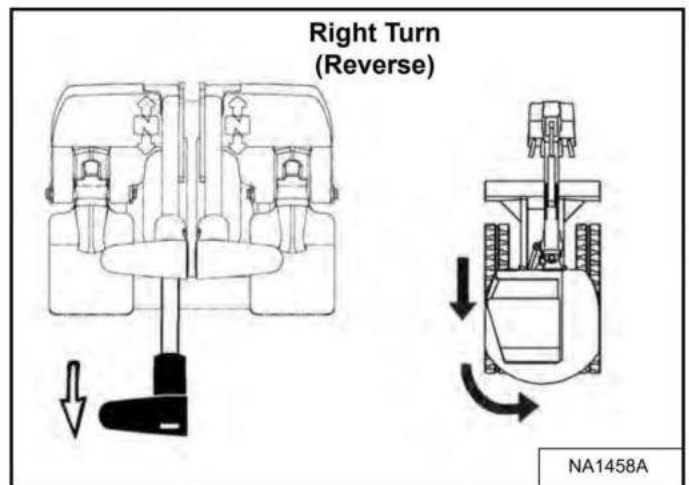

Pull the left steering lever backward to turn right while traveling backward [Figure 40]

Dealer Copy -- Not for Resale

TRAVEL CONTROLS (CONT'D)

Turning (Cont'd)

Counter-Rotation Right Turn

Figure 41

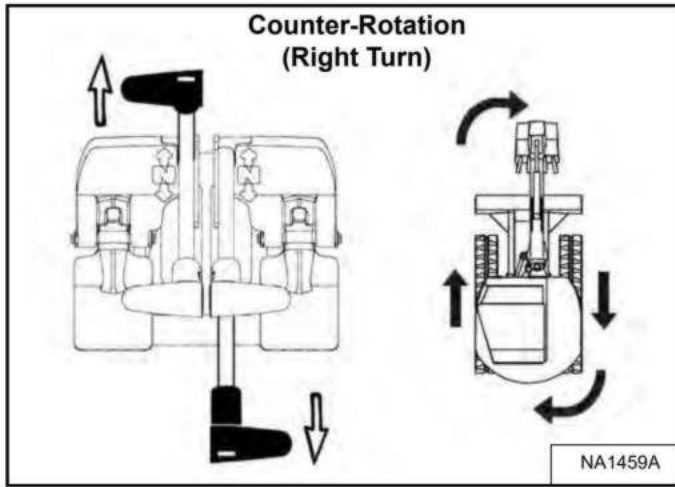

Push the left steering lever forward and pull the right steering lever backward [Figure 41].

Left Turn

Figure 42

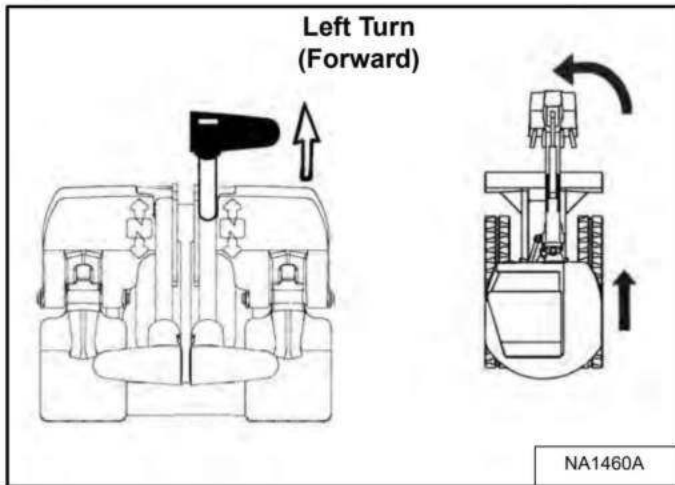

Push the right steering lever forward to turn left while traveling forward [Figure 42].

Figure 43

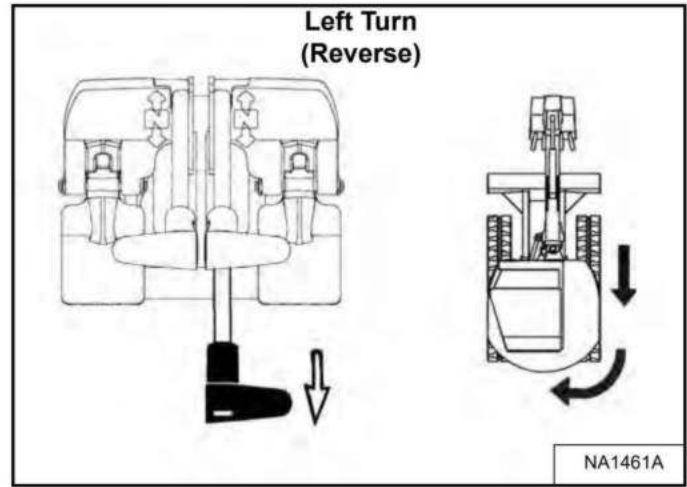

Pull the right steering lever backward to turn left while traveling backward [Figure 43].

Counter-Rotation Left Turn

Figure 44

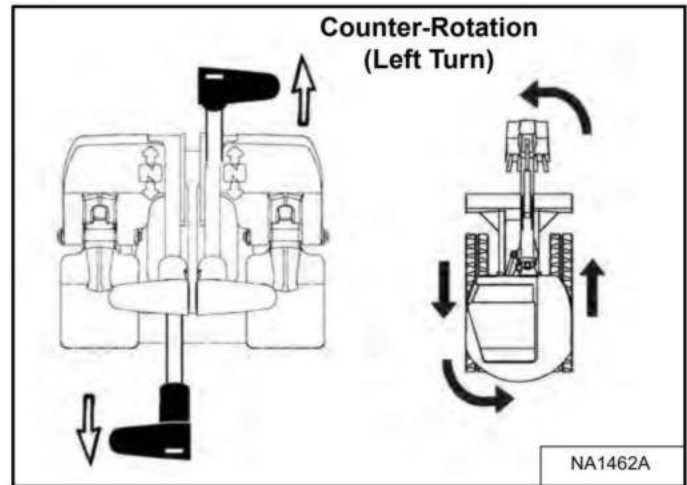

Push the right steering lever forward and pull the left steering lever backward [Figure 44].

HYDRAULIC CONTROLS

Description

The work equipment (boom, arm, bucket, and upperstructure slew) is operated by using the left and right control levers (joysticks). These joysticks can be used in either a STANDARD Control Pattern [Figure 45] and [Figure 46] or in the ISO Control Pattern [Figure 47] and [Figure 48]. (See STD / ISO Selector Valve on Page 30.)

STANDARD Control Pattern

Left Control Lever (Joystick)

Figure 45

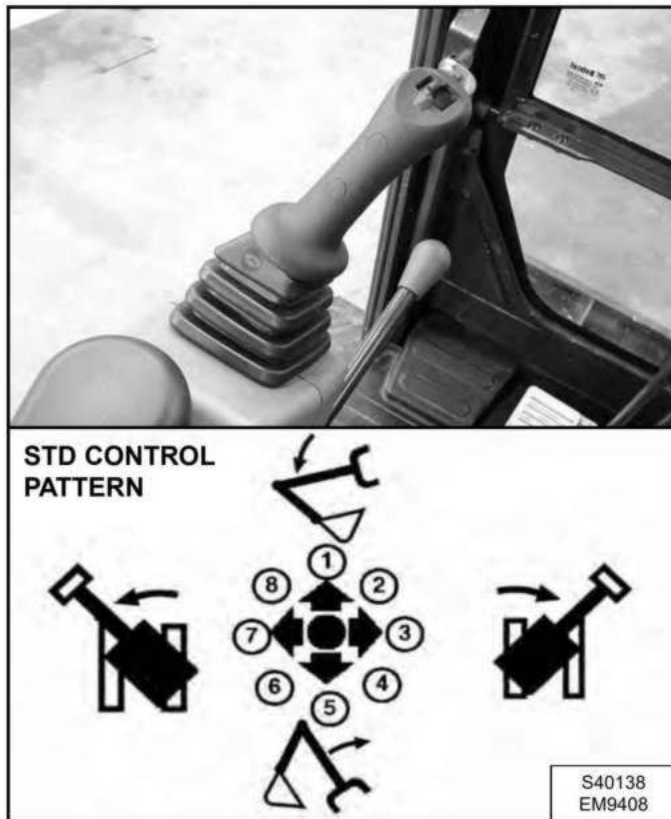

The left lever (joystick) is used to operate the boom and slew the upperstructure [Figure 45].

1. Boom lower.
2. Boom lower and slew right.
3. Slew right.
4. Boom raise and slew right.
5. Boom raise.
6. Boom raise and slew left.
7. Slew left.
8. Boom lower and slew left.

Right Control Lever (Joystick)

Figure 46

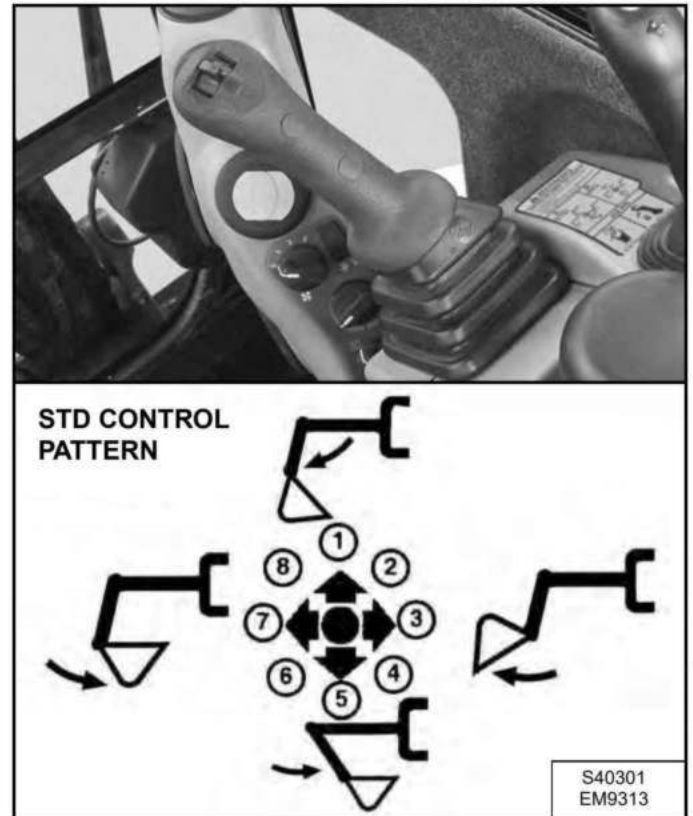

The right lever (joystick) is used to operate the arm and bucket [Figure 46].

1. Arm out.
2. Arm out and bucket dump.
3. Bucket dump.
4. Arm in and bucket dump.
5. Arm in.
6. Arm in and bucket curl.
7. Bucket curl.
8. Arm out and bucket curl.



AVOID INJURY OR DEATH

Before leaving the machine:

- Lower the work equipment to the ground.
- Lower the blade to the ground.
- Stop the engine & remove the key.
- Raise the control console.

W-2780-0109

Dealer Copy -- Not for Resale

HYDRAULIC CONTROLS (CONT'D)

ISO Control Pattern

Left Control Lever (Joystick)

Figure 47

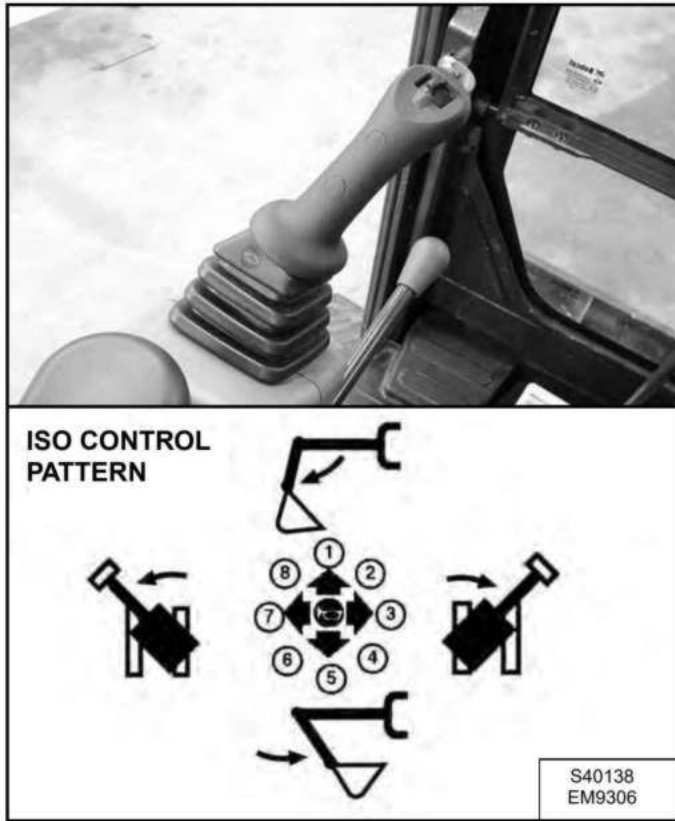

The left lever (joystick) is used to operate the boom and slew the upperstructure [Figure 47].

1. Arm out.
2. Arm out and slew right.
3. Slew right.
4. Arm in and slew right.
5. Arm in.
6. Arm in and slew left.
7. Slew left.
8. Arm out and slew left.

Right Control Lever (Joystick)

Figure 48

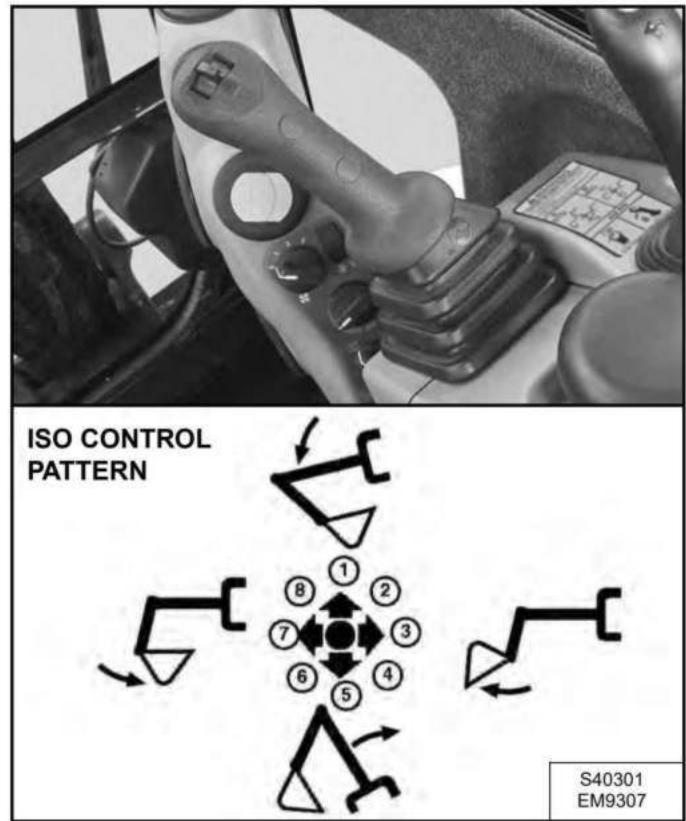

The right lever (joystick) is used to operate the arm and bucket [Figure 48].

1. Boom lower.
2. Boom lower and bucket dump.
3. Bucket dump.
4. Boom raise and bucket dump.
5. Boom raise.
6. Boom raise and bucket curl.
7. Bucket curl.
8. Boom lower and bucket curl.

WARNING

AVOID INJURY OR DEATH

Before leaving the machine:

- Lower the work equipment to the ground.
- Lower the blade to the ground.
- Stop the engine & remove the key.
- Raise the control console.

W-2780-0109

HYDRAULIC CONTROLS (CONT'D)

Quick Couplers

! WARNING

AVOID BURNS

Hydraulic fluid, tubes, fittings and quick couplers can get hot when running machine and attachments. Be careful when connecting and disconnecting quick couplers.

W-2220-0396

! WARNING

AVOID INJURY OR DEATH

Diesel fuel or hydraulic fluid under pressure can penetrate skin or eyes, causing serious injury or death. Fluid leaks under pressure may not be visible. Use a piece of cardboard or wood to find leaks. Do not use your bare hand. Wear safety goggles. If fluid enters skin or eyes, get immediate medical attention from a physician familiar with this injury.

W-2072-0807

Figure 49

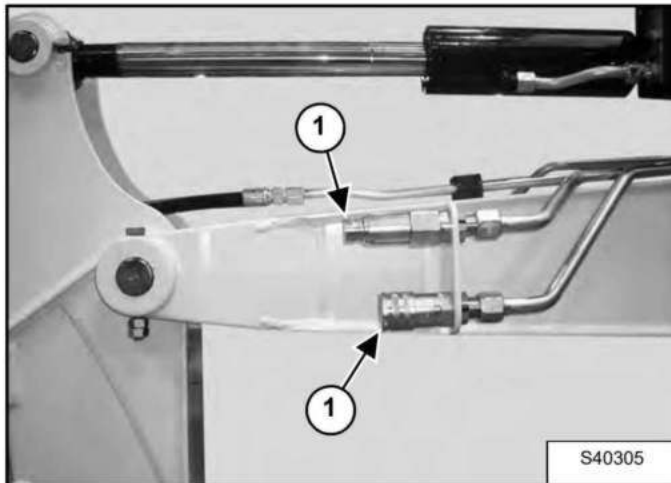

Excavators and attachments are supplied with flush faced couplers (Item 1) [Figure 49].

To Connect:

Remove any dirt or debris from the surface of both the male and female couplers, and from the outside diameter of the male coupler. Visually check the couplers for corroding, cracking, damage, or excessive wear, if any of these conditions exist, the coupler(s) (Item 1) [Figure 49] must be replaced.

Install the male coupler into the female coupler. Full connection is made when the ball release sleeve slides forward on the female coupler.

To Disconnect:

Figure 50

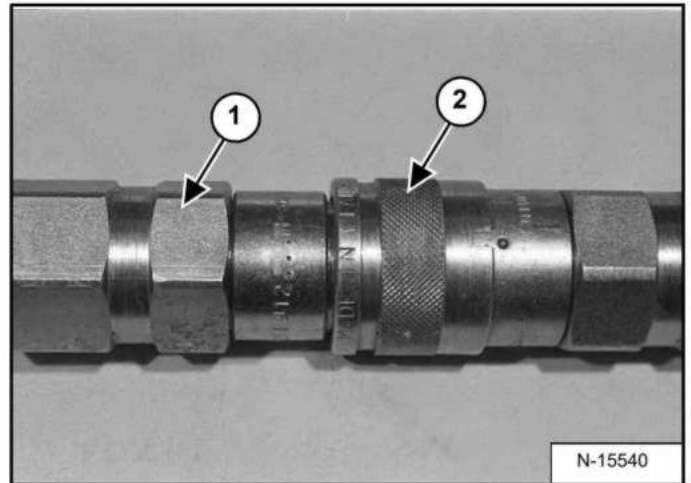

Hold the male coupler (Item 1). Retract the sleeve (Item 2) [Figure 50] on the female coupler until the couplers disconnect.

Dealer Copy -- Not for Resale

HYDRAULIC CONTROLS (CONT'D)

Auxiliary Hydraulics

Figure 51

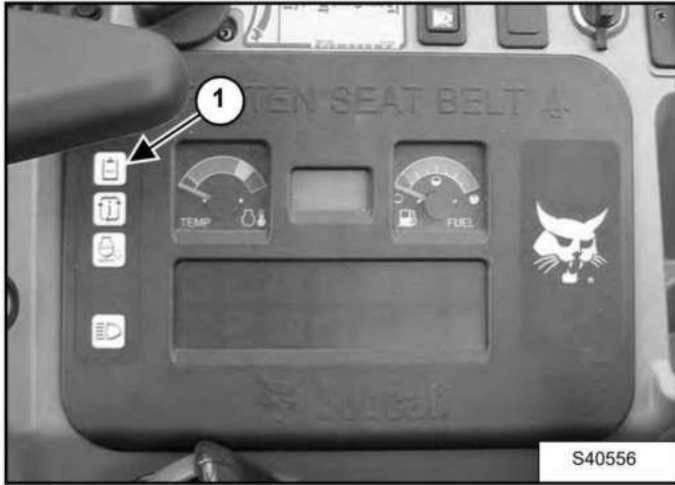

Press the Auxiliary Hydraulics button on the right console (Item 1) [Figure 51].

Figure 52

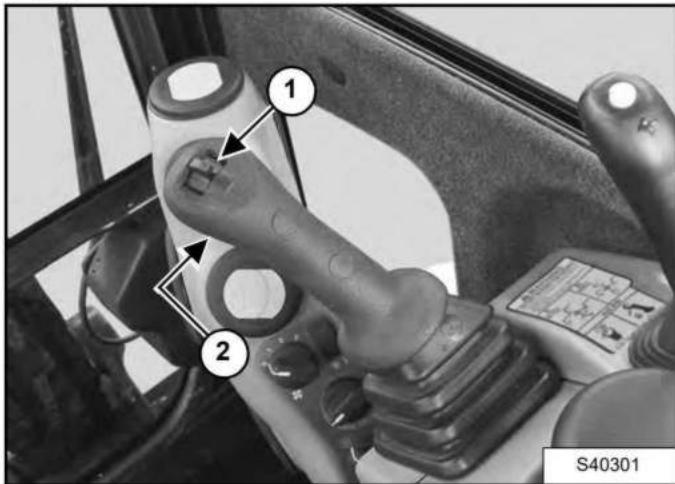

Move the switch (Item 1) [Figure 52] on the right control lever to the right to supply hydraulic flow to the female coupler. Move the switch to the left to supply hydraulic flow to the male coupler. If you move the switch halfway, the auxiliary functions move at approximately one-half speed.

Press the switch (Item 2) [Figure 52] on the front of the handle to provide constant flow to the female coupler.

NOTE: Pressing the switch (Item 1) to the left while pressing the switch (Item 2) [Figure 52] on the front of the handle will provide constant flow to the male coupler.

Press the switch (Item 2) [Figure 52] a second time to stop auxiliary flow to the quick couplers.

Relieve Hydraulic Pressure (Excavator And Attachment)

Excavator:

Put the attachment flat on the ground.

Stop the engine and turn the key to ON (Standard) or press ENTER CODE Button (Keyless).

NOTE: The left console must be fully lowered for relieving hydraulic pressure.

Press AUX HYD Button (Item 1) [Figure 51] and then move the switch (Item 1) [Figure 52] to the right and left several times.

Attachments:

- Follow procedure above to release pressure in excavator.
- Connect male coupler from attachment to female coupler of excavator then repeat procedure above. This will release pressure in the attachment.
- Connect the female coupler from the attachment.

Hydraulic pressure in the auxiliary hydraulic system can make it difficult to engage quick couplers to an attachment.

HYDRAULIC CONTROLS (CONT'D)

Secondary Auxiliary Hydraulics

When equipped with secondary auxiliary hydraulics, the second set of hydraulic couplers will be mounted on the right side of the arm.

Figure 53



Move the boom swing / secondary auxiliary hydraulic switch (Item 1) [Figure 53] to the right, secondary auxiliary hydraulic position.

Figure 54

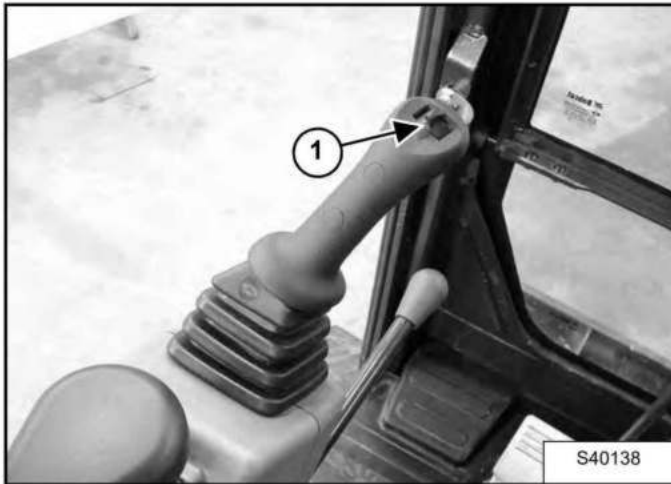

Move the switch (Item 1) [Figure 54] on the left control lever to the left to supply hydraulic flow to the female coupler. Move the switch to the right to supply hydraulic flow to the male coupler. If you move the switch halfway, the auxiliary functions move at approximately one-half speed.

Relieve Hydraulic Pressure (Excavator And Attachment)

Excavator:

Put the attachment flat on the ground.

Stop the engine and turn the key to ON (Standard) or press ENTER CODE Button (Keyless).

NOTE: The left console must be fully lowered for relieving hydraulic pressure.

Move the boom swing / secondary auxiliary hydraulic switch (Item 1) [Figure 53] to the right, secondary auxiliary hydraulic position.

Move the switch (Item 1) [Figure 54] to the right and left several times.

Attachments:

- Follow procedure above to release pressure in excavator.
- Connect male coupler from attachment to female coupler of excavator then repeat procedure above. This will release pressure in the attachment.
- Connect the female coupler from the attachment.

Hydraulic pressure in the auxiliary hydraulic system can make it difficult to engage quick couplers to an attachment.

Dealer Copy -- Not for Resale

HYDRAULIC CONTROLS (CONT'D)

Direct To Tank Valve

The direct to tank valve (if equipped) is located under the cab floor.

Remove the floor mat and floor panel. (See the Service Manual for the correct procedure.)

Figure 55



Rotate the lever (Item 1) **[Figure 55]** clockwise to direct auxiliary return flow to the hydraulic oil reservoir.

Rotate the lever (Item 1) **[Figure 55]** counterclockwise for two way hydraulic auxiliary flow operation.

BLADE CONTROL LEVER

Raising And Lowering Blade

Figure 56

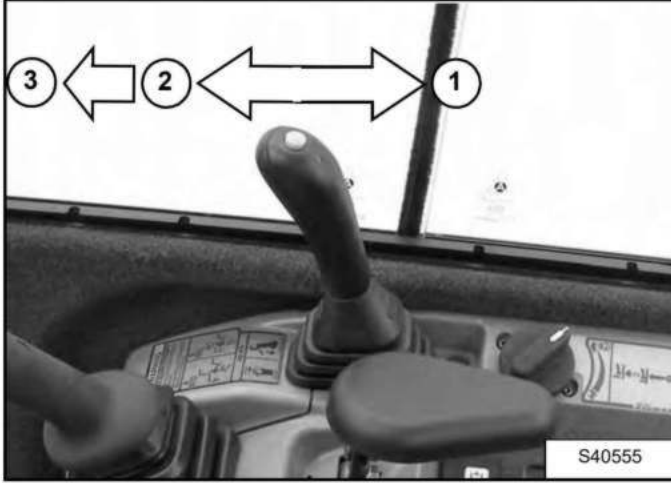

Pull the lever backward to raise the blade (Item 1) [Figure 56].

Push the lever forward to lower the blade (Item 2) [Figure 56].

Push the lever (Item 3) [Figure 56] forward until the lever is in the locked position to put the blade in the *float* position.

Pull the lever backward to unlock from the *float* position.

NOTE: Keep blade lowered for increased digging performance.

ENGINE SPEED CONTROL

Setting Engine Speed (RPM)

Figure 57

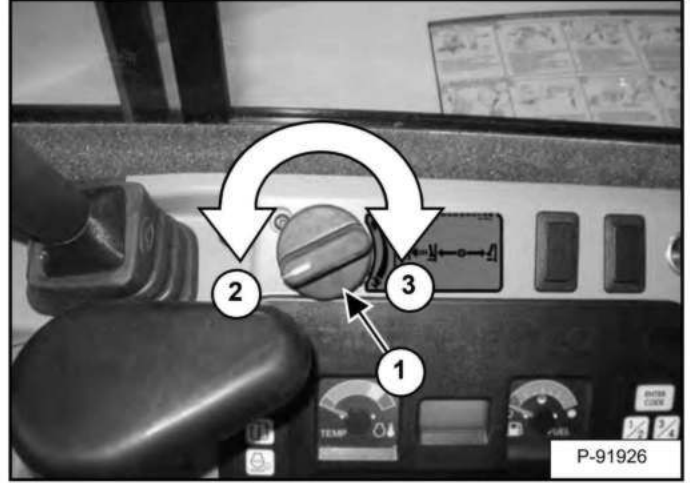

The engine speed control dial (Item 1) [Figure 57] controls engine rpm along with the auto idle feature (when engaged).

Rotate the engine speed control dial counterclockwise (Item 2) to reduce engine rpm. Rotate the engine speed control dial clockwise (Item 3) [Figure 57] to increase engine rpm.

BOOM SWING

Operation

Figure 58

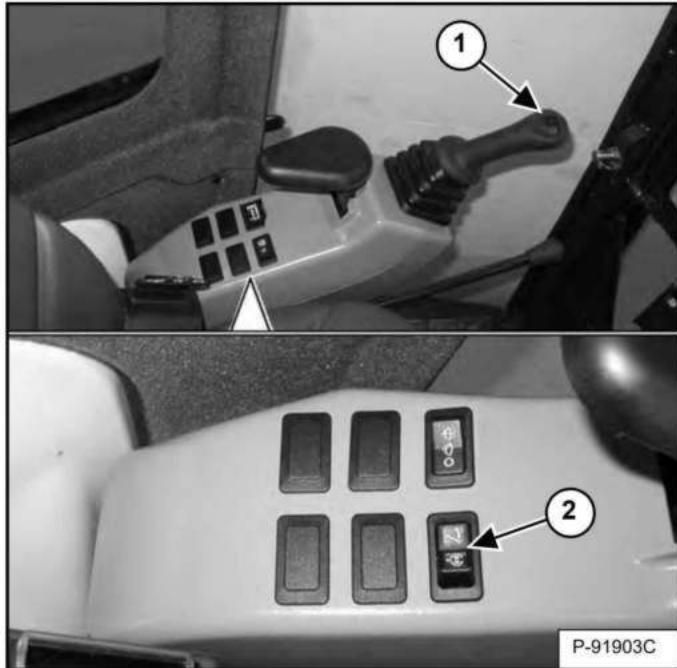

The switch (Item 1) [Figure 58] on the left control lever (joystick) controls boom swing. Move the switch to the left to swing the boom to the left. Move the switch to the right to swing the boom to the right.

With Secondary Auxiliary Hydraulics:

If the machine is equipped with secondary auxiliary hydraulic couplers, the switch (Item 2) [Figure 58] is used to select either the boom swing function or the secondary auxiliary hydraulic function.

Move the switch (Item 2) [Figure 58] to the left to select boom swing function, move the switch to the right to select secondary auxiliary hydraulic function.

Figure 59



NOTE: The purpose of the boom swing is to offset the boom with respect to the upperstructure for digging close to a structure [Figure 59].

DAILY INSPECTION

Daily Inspection And Maintenance

Figure 60



Maintenance work must be done at regular intervals. Failure to do so will result in excessive wear and early failures. The service schedule is a guide for correct maintenance of the Bobcat excavator. The decal (Item 1) [Figure 60] is located on the rear door top of the tailgate cover. (See SERVICE SCHEDULE on Page 87.)

Check the following items before each day of operation:

- Operator Canopy or Cab (ROPS / TOPS) and mounting hardware.
- Seat belt and mounting hardware. Replace seat belt if damaged.
- Check for damaged decals, replace as needed.
- Check control console lockout.
- Check X-Change System (if equipped) for damage or loose parts.
- Air cleaner and intake hoses / clamps.
- Engine oil level and engine for leaks.
- Engine coolant level and engine for leaks.
- Check engine area for flammable materials.
- Check hydraulic oil level and system for leaks.
- Check indicator lights for correct operation.
- Grease all pivot points.
- Check cylinder and attachment pivot points.
- Check the track tension.
- Repair broken and loose parts.
- Clean cab heater filter (if equipped).
- Check front horn and motion alarm (if equipped) for proper function.

WARNING

Operator must have instructions before operating the machine. Untrained operators can cause injury or death.

W-2001-0502

Fluids such as engine oil, hydraulic oil, coolants, etc. must be disposed of in an environmentally safe manner. Some regulations require that certain spills and leaks on the ground must be cleaned in a specific manner. See local state and federal regulations for correct disposal.

IMPORTANT

PRESSURE WASHING DECALS

- Never direct the stream at a low angle toward the decal that could damage the decal causing it to peel from the surface.
- Direct the stream at a 90 degree angle and at least 300 mm (12 in) from the decal. Wash from the center of the decal toward the edges.

I-2226-0910

IMPORTANT

This machine is factory equipped with a U.S.D.A. Forestry Service approved spark arrester exhaust system.

The spark arrester muffler, if equipped, must be cleaned to keep it in working condition. The spark arrester muffler must be serviced by dumping the spark chamber every 100 hours of operation.

On some models, the turbocharger functions as the spark arrester and must operate correctly for proper spark arrester function.

If this machine is operated on flammable forest, brush, or grass covered land, it must be equipped with a spark arrester attached to the exhaust system and maintained in working order. Failure to do so will be in violation of California State Law, Section 4442. PRC. Refer to local laws and regulations for spark arrester requirements.

I-2284-0111

PRE-STARTING PROCEDURE

Operation & Maintenance Manual And Operator's Handbook Locations

Figure 61

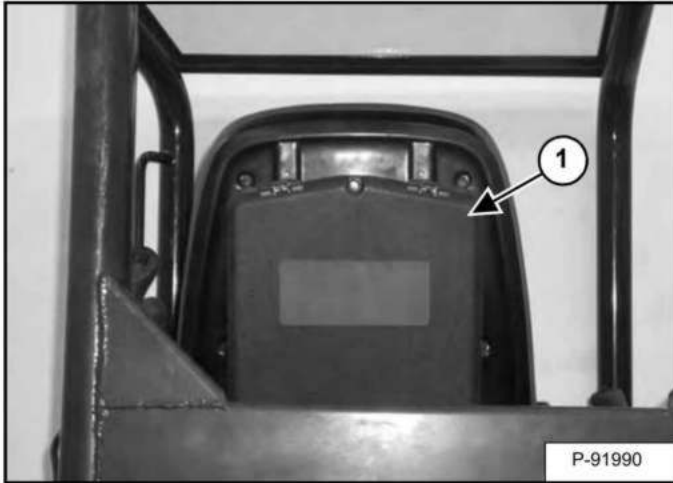
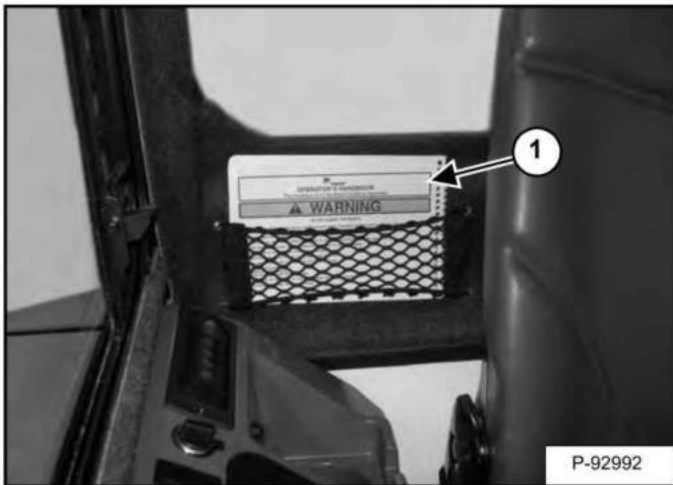

Figure 62



Read and understand the Operation & Maintenance Manual (Item 1) [Figure 61] (located inside the storage box on the back of the operator's seat) and the Operator's Handbook (Item 1) [Figure 62] before operating.

Entering The Excavator

Figure 63



Use the grab handles and tracks to enter the canopy / cab [Figure 63].

! WARNING

AVOID INJURY OR DEATH

Instructions are necessary before operating or servicing machine. Read and understand the Operation & Maintenance Manual, Operator's Handbook and signs (decals) on machine. Follow warnings and instructions in the manuals when making repairs, adjustments or servicing. Check for correct function after adjustments, repairs or service. Untrained operators and failure to follow instructions can cause injury or death.

W-2003-0807

PRE-STARTING PROCEDURE (CONT'D)

Seat Adjustment

Standard Seat

Figure 64



Release the seat lever (Item 1) [Figure 64] to adjust the seat forward or back.

Sit in the seat and turn the knob (Item 2) [Figure 64] to adjust the position of the back cushion.

Suspension Seat (If Equipped)

Figure 65

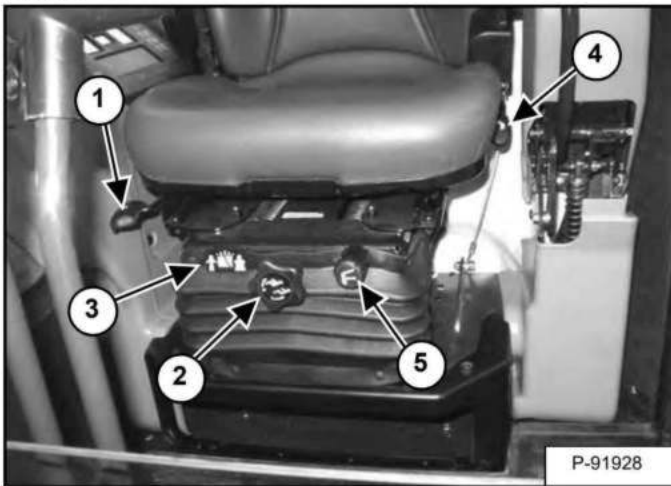

Release the seat lever (Item 1) [Figure 65] to adjust the seat forward or back.

Turn the handle (Item 2) to change the adjustment for operator weight. Turn the handle until the operator's weight is shown in the window (Item 3) [Figure 65].

Release the lever (Item 4) [Figure 65] to adjust the position of the back cushion.

Sit in the seat and turn the knob (Item 5) [Figure 65] to adjust the height of the seat.

Seat Belt

Figure 66



Fasten the seat belt [Figure 66].

PRE-STARTING PROCEDURE (CONT'D)

Control Console

Figure 67



Lower the control console [Figure 67].

NOTE: There is a control lock sensor in the left console which deactivates the hydraulic control levers (joysticks) and the traction drive system when the control console is raised. The console must be in the locked down position for the hydraulic control levers (joysticks) and traction system to operate.

NOTE: If the control lock sensor does not deactivate the control levers and traction system when console is raised, see your Bobcat dealer for service.

Mirror Adjustment

Figure 68

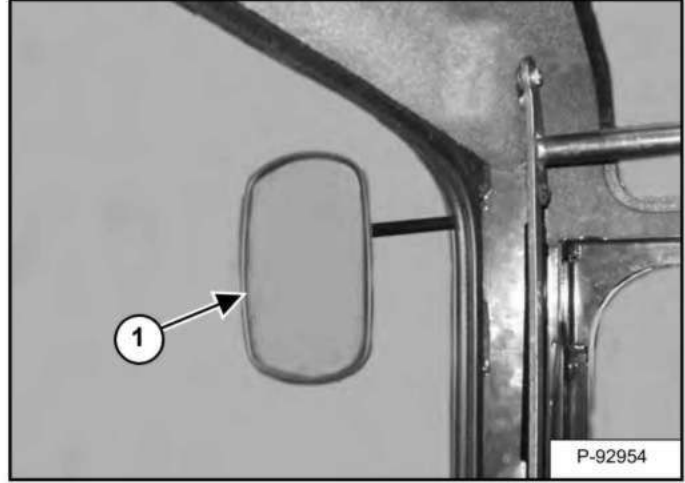

Adjust mirrors (Item 1) [Figure 68] (if equipped).

STARTING THE ENGINE

Key Switch



AVOID SERIOUS INJURY OR DEATH

- Engines can have hot parts and hot exhaust gas. Keep flammable material away.
- Do not use machines in atmosphere containing explosive dust or gases.

W-2051-0212

Perform the PRE-STARTING PROCEDURE. (See PRE-STARTING PROCEDURE on Page 52.)

Figure 69

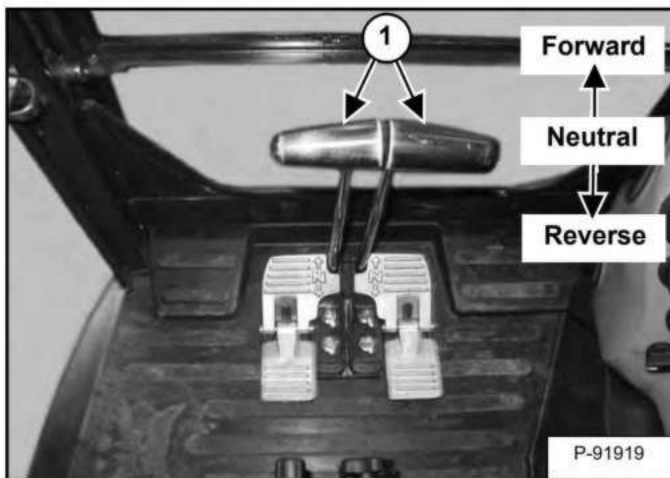

Put control levers (Item 1) [Figure 69] in the neutral position.

Figure 70

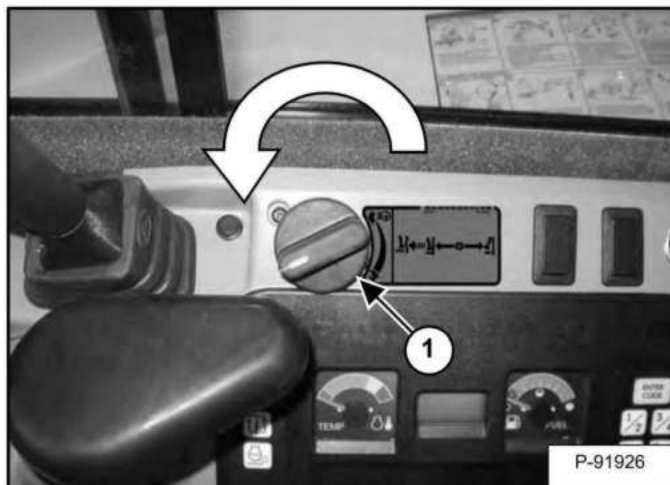

Rotate the engine speed control dial (Item 1) [Figure 70] counterclockwise to low idle.

Figure 71

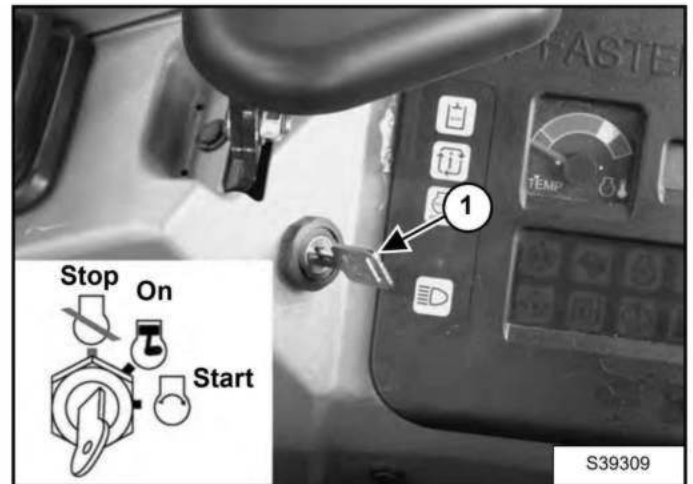

Turn the key (Item 1) [Figure 71] to the ON position. If preheating is required, the glow plugs will automatically cycle and the remaining preheat time (in seconds) will show in the data display screen. (Preheat icon will be ON).

Turn the key to START and release the key when the engine starts. It will return to the ON position [Figure 71].



AVOID INJURY OR DEATH

- Fasten seat belt, start and operate only from the operator's seat.
- Never wear loose clothing when working near machine.

W-2135-1108



Do not engage the starter for longer than 15 seconds at a time. Longer use can damage the starter by overheating. Allow starter to cool for one minute before using starter again.

I-2034-0700

Stop the engine if the warning lights and alarm do not go OFF. Check for the cause before starting the engine again.

Turn the key switch OFF to stop the engine.

Dealer Copy -- Not for Resale

STARTING THE ENGINE (CONT'D)

Keyless

! WARNING

AVOID SERIOUS INJURY OR DEATH

- Engines can have hot parts and hot exhaust gas. Keep flammable material away.
- Do not use machines in atmosphere containing explosive dust or gases.

W-2051-0212

Perform the PRE-STARTING PROCEDURE. (See PRE-STARTING PROCEDURE on Page 52.)

Figure 72

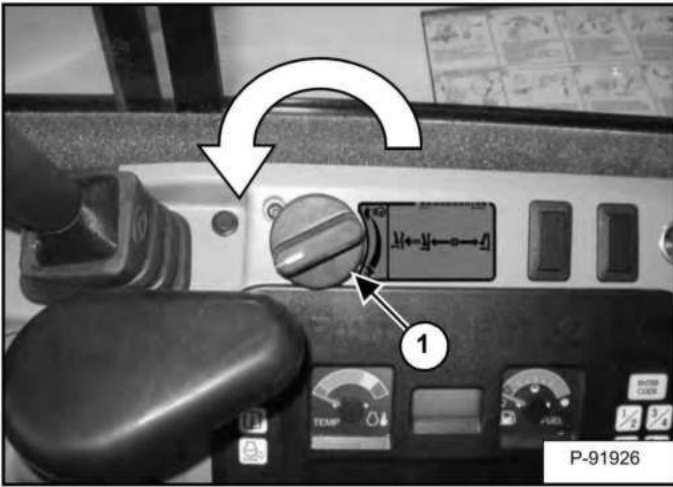

Rotate the engine speed control dial (Item 1) [Figure 72] counterclockwise to low idle.

! WARNING

AVOID INJURY OR DEATH

- Fasten seat belt, start and operate only from the operator's seat.
- Never wear loose clothing when working near machine.

W-2135-1108

Figure 73

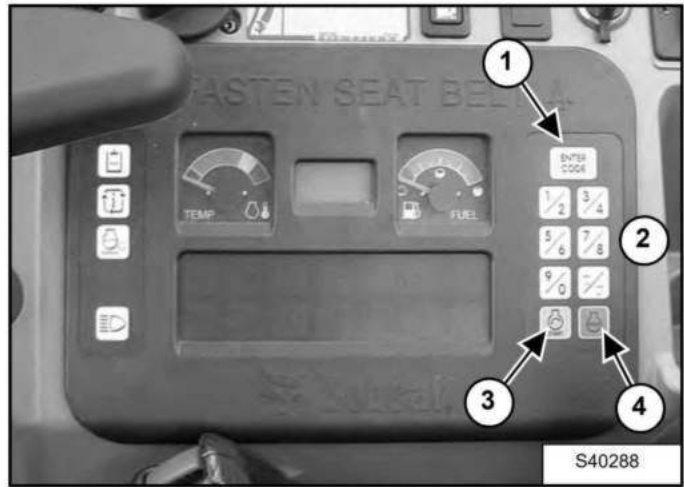

Press ENTER CODE Button (Item 1) [Figure 73]. The display will become lighted and there will be two short beeps, "CodE" will appear on the display screen.

Use the keypad (Item 2) [Figure 73] to enter the password. For each digit that you enter, a dash will appear on the data display screen. (You have 40 seconds to enter the password or the process will abort and you will need to start over.) If the password was entered correctly, there will be one long beep.

NOTE: If the password was incorrect there will be three short beeps and "Error" will appear on the data display screen. Press the ENTER CODE Button again and start over. After three failed attempts, you must wait 3 minutes to try again.

Press the START Button (Item 3) [Figure 73] and hold it until the engine starts.

IMPORTANT

Do not engage the starter for longer than 15 seconds at a time. Longer use can damage the starter by overheating. Allow starter to cool for one minute before using starter again.

I-2034-0700

STARTING THE ENGINE (CONT'D)

Keyless (Cont'd)

Press the STOP button (Item 4) [Figure 73] to stop the engine.

Stop the engine if the warning lights and alarm do not go OFF.

Check for the cause before starting the engine again.

Password Lockout Feature

See Password Lockout Feature. (See Password Lockout Feature on Page 134.)

! WARNING

AVOID INJURY OR DEATH

When an engine is running in an enclosed area, fresh air must be added to avoid concentration of exhaust fumes. If the engine is stationary, vent the exhaust outside. Exhaust fumes contain odorless, invisible gases which can kill without warning.

W-2050-0807

Cold Temperature Starting

! WARNING

AVOID INJURY OR DEATH

Do not use ether with glow plug (preheat) systems. Explosion can result which can cause injury, death, or severe engine damage.

W-2071-0907

If the temperature is below freezing, perform the following to make starting the engine easier:

- Replace the engine oil with the correct type and viscosity for the anticipated starting temperature. (See Engine Oil Chart on Page 101.)
- Make sure the battery is fully charged.
- Install an engine heater.

NOTE: If the battery is discharged (but not frozen) a booster battery can be used to jump start the excavator. (See Using A Booster Battery (Jump Starting) on Page 108.)

Figure 74

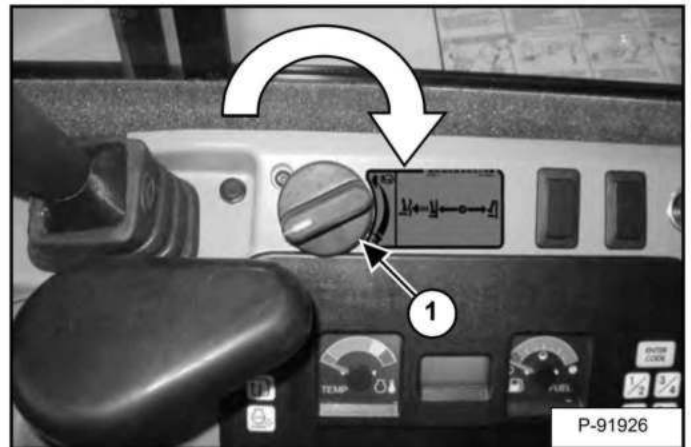

Rotate the engine speed control dial (Item 1) [Figure 74] clockwise to high idle.

IMPORTANT

Do not engage the starter for longer than 15 seconds at a time. Longer use can damage the starter by overheating. Allow starter to cool for one minute before using starter again.

I-2034-0700

Dealer Copy -- Not for Resale

STARTING THE ENGINE (CONT'D)

Cold Temperature Starting Procedure (Cont'd)

Key Switch

Figure 75

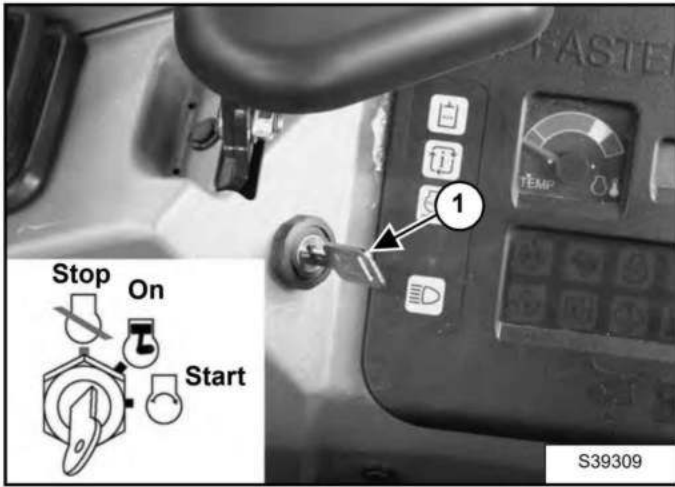

Turn the key to the ON position [Figure 75].

Figure 76



The preheat icon (Item 1) [Figure 76] will illuminate. The glow plugs will automatically cycle. When the icon goes off, turn the key to start.

Release the key when the engine starts, it will return to the ON position.

Stop the engine if the warning lights and alarm do not go off. Check for the cause before starting the engine again.

When the engine speed increases, move the engine speed control dial to idle position until the engine warms.

Keyless

Follow STARTING PROCEDURE (See Keyless on Page 56.)

If the preheat icon comes ON, wait for it to go off before pressing the START Button (Item 1) [Figure 76].

The remaining preheat time (in seconds) will count down in the data display screen.

IMPORTANT

Do not engage the starter for longer than 15 seconds at a time. Longer use can damage the starter by overheating. Allow starter to cool for one minute before using starter again.

I-2034-0700

IMPORTANT

Machines warmed up with moderate engine speed and light load have longer life.

I-2015-0284

! WARNING

AVOID INJURY OR DEATH

Do not use ether with glow plug (preheat) systems. Explosion can result which can cause injury, death, or severe engine damage.

W-2071-0907

Warming The Hydraulic System

IMPORTANT

When the temperature is below -30°C (-20°F), hydrostatic oil must be warmed before starting. The hydrostatic system will not get enough oil at low temperatures and will be damaged. Park the machine in an area where the temperature will be above -18°C (0°F) if possible.

I-2007-0910

Let the engine run at least 5 minutes to warm the engine and hydraulic oil before operating the excavator.

STOPPING THE ENGINE AND LEAVING THE EXCAVATOR

Procedure

Figure 77



Stop the machine on level ground. Lower the work equipment and the blade to the ground [Figure 77].

Figure 78

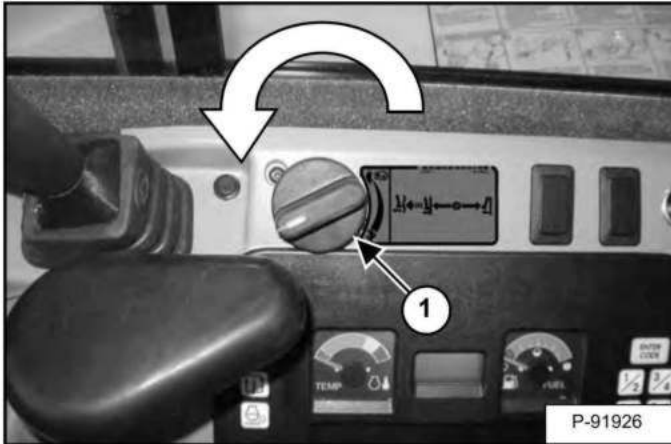

Rotate the engine speed control dial (Item 1) [Figure 78] counterclockwise to low idle.

Run the engine at idle speed for about 5 minutes to allow it to cool.

Figure 79

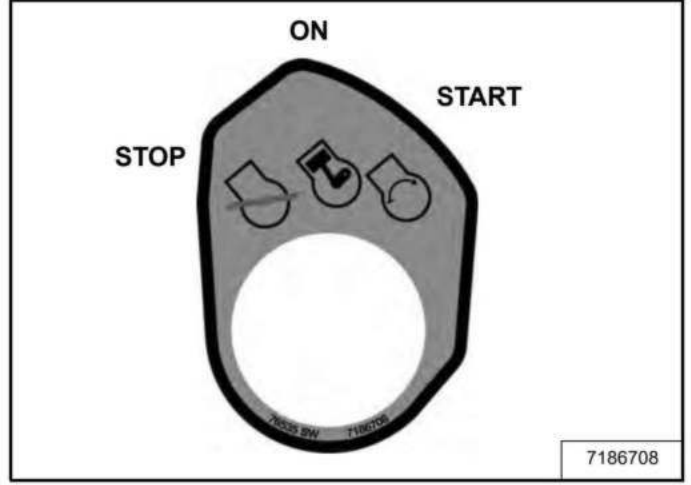

Figure 80



Turn the key switch to STOP [Figure 79] or press the STOP Button (Keyless Panel) (Item 1) [Figure 80].

Disconnect the seat belt. Remove the key (if equipped) from the switch to prevent operation of machine by unauthorized personnel. Raise the control console and exit the machine.

Dealer Copy -- Not for Resale

ATTACHMENTS

Installing And Removing The Attachment (Pin-On X-Change)

Installation

NOTE: Installation and removal of the bucket is shown. The procedure is the same for other attachments. Disconnect any hydraulic lines that are operated by hydraulic power before removing any attachments (breaker, auger, etc.).

WARNING

AVOID INJURY OR DEATH

Never use attachments or buckets which are not approved by Bobcat Company. Buckets and attachments for safe loads of specified densities are approved for each model. Unapproved attachments can cause injury or death.

W-2052-0907

Figure 81

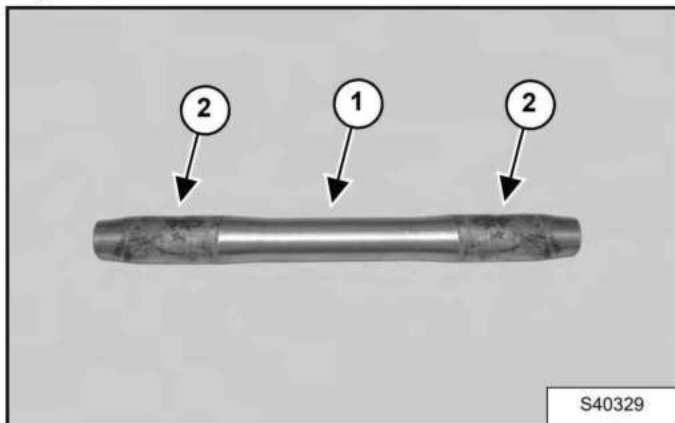

Inspect the pin (Item 1) [Figure 81] for wear or damage. Replace the pin as needed.

Apply a light coat of grease to the ends of the pin (Item 2) [Figure 81].

Figure 82



Start the engine and move the arm toward the bucket [Figure 82].

Dealer Copy -- Not for Resale

ATTACHMENTS (CONT'D)

Installing And Removing The Attachment (Pin-On X-Change) (Cont'd)

Installation (Cont'd)

Figure 83

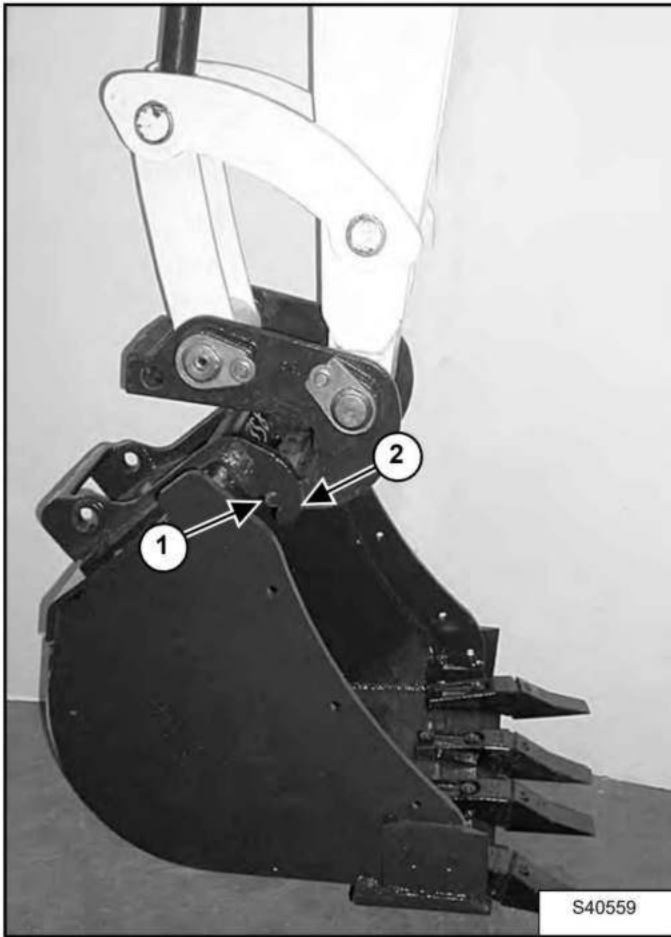

Raise the boom until the pins (Item 1) engage the hooks (Item 2) [Figure 83] on the bucket.

Figure 84

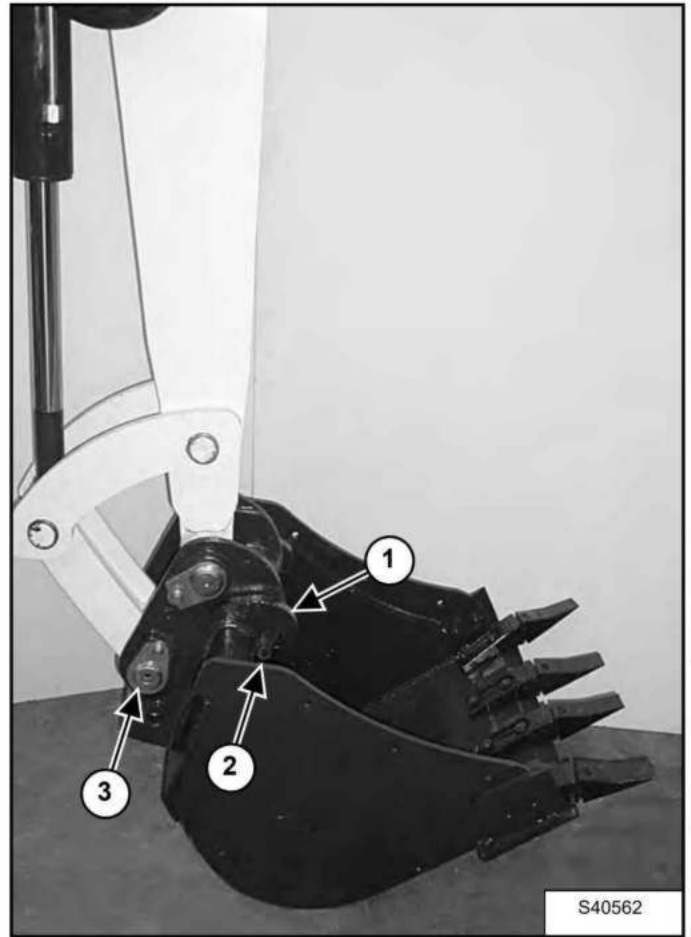

Raise the boom and extend the bucket cylinder until the X-Change contacts the attachment back [Figure 84].

With the arm vertical, lower the boom until the hooks (Item 1) of the bucket disengage the pins (Item 2) of the X-Change and the plate (Item 3) [Figure 84] fully engages in the bucket crossmember.

WARNING

Keep all bystanders 6 m (20 ft) away from equipment when operating. Contact with moving parts, a trench cave-in or flying objects can cause injury or death.

W-2119-0910

Dealer Copy -- Not for Resale

ATTACHMENTS (CONT'D)

Installing And Removing The Attachment (Pin-On X-Change) (Cont'd)

Installation (Cont'd)

Figure 85

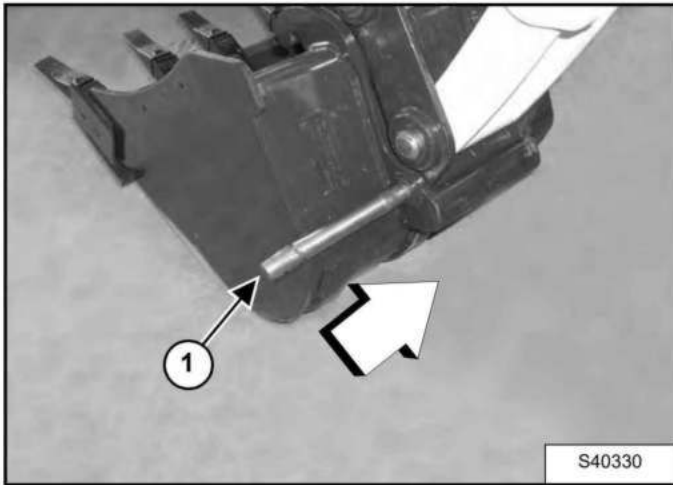

Stop the engine. Turn the start key to the ON position and move both hydraulic control levers to relieve hydraulic pressure.

Drive the pin (Item 1) **[Figure 85]** through the bucket mount and X-Change.

Figure 86

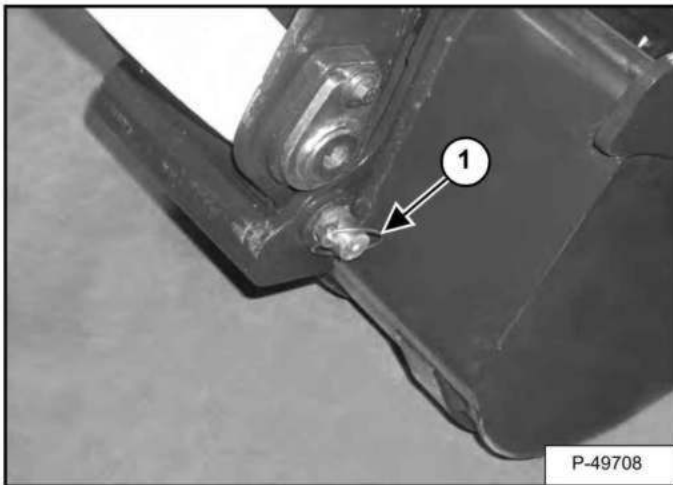

Install the retainer pins (Item 1) **[Figure 86]** (both sides).

Check for proper installation.

Lift the attachment and fully extend and retract the bucket cylinder.

ATTACHMENTS (CONT'D)

Installing And Removing The Attachment (Pin-On X-Change) (Cont'd)

Removal

NOTE: Removal and installation of the bucket is shown. The procedure is the same for other attachments. Disconnect any hydraulic lines that are operated by hydraulic power before removing any attachments (breaker, auger, etc.).

WARNING

AVOID INJURY OR DEATH

Never use attachments or buckets which are not approved by Bobcat Company. Buckets and attachments for safe loads of specified densities are approved for each model. Unapproved attachments can cause injury or death.

W-2052-0907

Figure 87



Dealer Copy -- Not for Resale

Park the excavator on a flat level surface. Put the bucket on the ground [Figure 87].

With the engine off, turn the start key to the ON position and move both hydraulic control levers to relieve hydraulic pressure.

ATTACHMENTS (CONT'D)

Installing And Removing The Attachment (Pin-On X-Change) (Cont'd)

Removal (Cont'd)

Figure 88

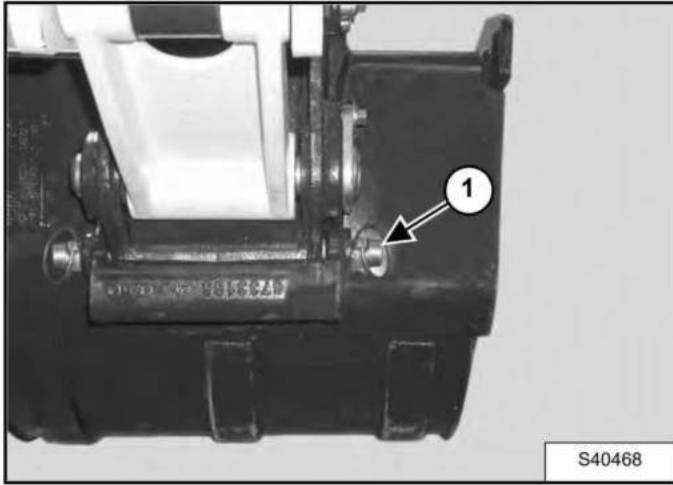

Remove the retainer pin (Item 1) [Figure 88].

Figure 89

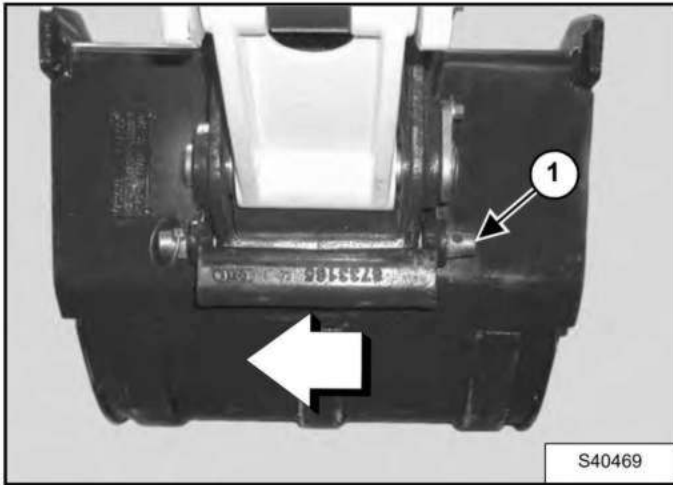

Drive the pin (Item 1) [Figure 89] out of the bucket and X-Change mount.



AVOID INJURY OR DEATH

Wear safety glasses to prevent eye injury when any of the following conditions exist:

- When fluids are under pressure.
- Flying debris or loose material is present.
- Engine is running.
- Tools are being used.

W-2019-0907

Figure 90

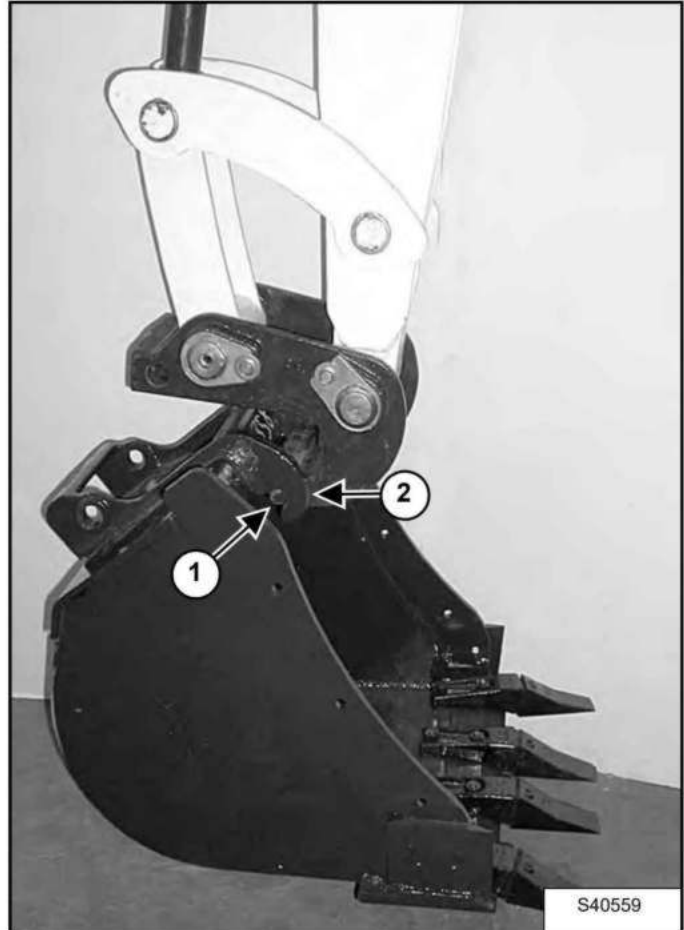

Start the engine, raise the boom approximately one foot and retract the bucket cylinder until the X-Change pins (Item 1) engage the hooks (Item 2) [Figure 90] on the bucket.

ATTACHMENTS (CONT'D)

Installing And Removing The Attachment (Pin-On X-Change) (Cont'd)

Removal (Cont'd)

Figure 91

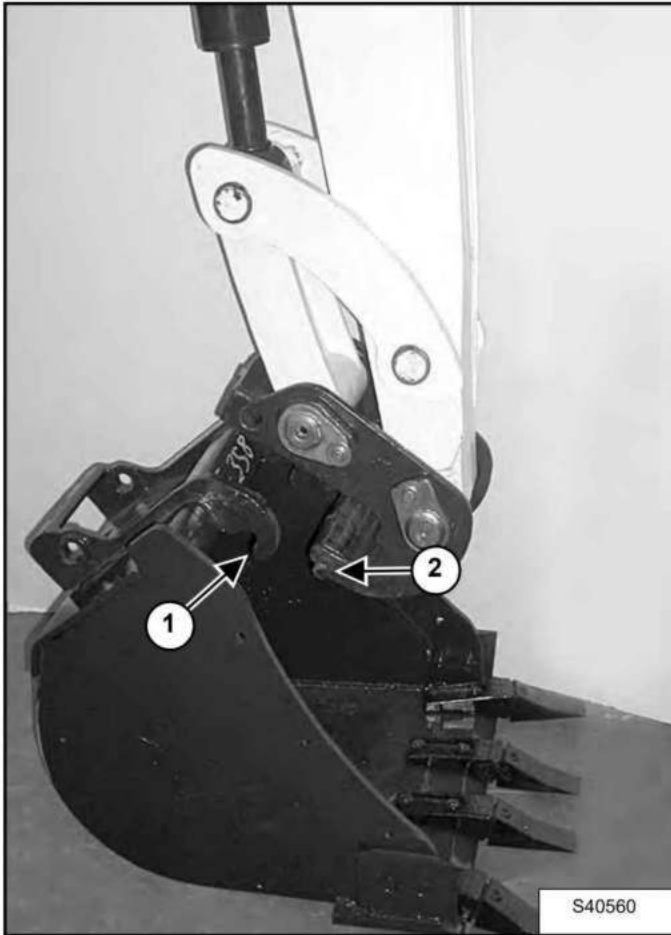

Fully retract the bucket cylinder and lower the boom and arm until the bucket is on the ground, and the X-Change pins (Item 1) are disengaged from the hooks (Item 2) [Figure 91].

Move the arm toward the excavator until the X-Change pins are clear of the bucket.

ATTACHMENTS (CONT'D)

Installing And Removing The Attachment (Pin-On Attachment)

Installation

! WARNING

AVOID INJURY OR DEATH

Stop the machine on a firm flat surface. When removing or installing attachments (such as a bucket), always have a second person in the operator's seat, give clear signals and work carefully.

W-2140-0189

Figure 92

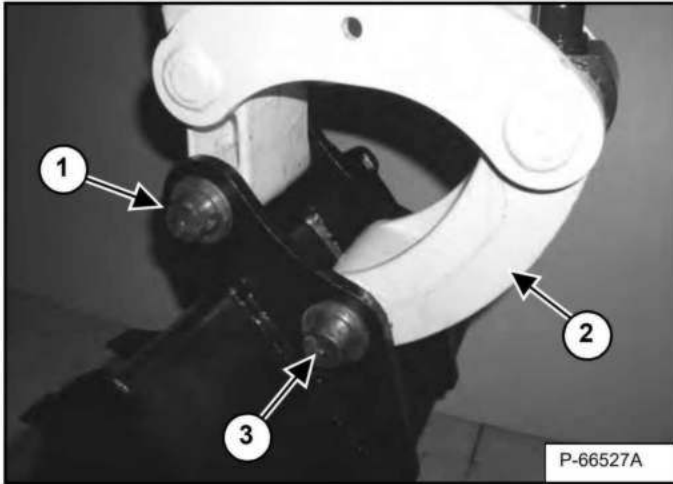

Install the arm into the bucket and align the mounting hole.

Install the pin (Item 1) [Figure 92] and washers.

Install the link (Item 2) in the bucket and align the mounting hole. Install the pin (Item 3) [Figure 92] and washers.

Figure 93

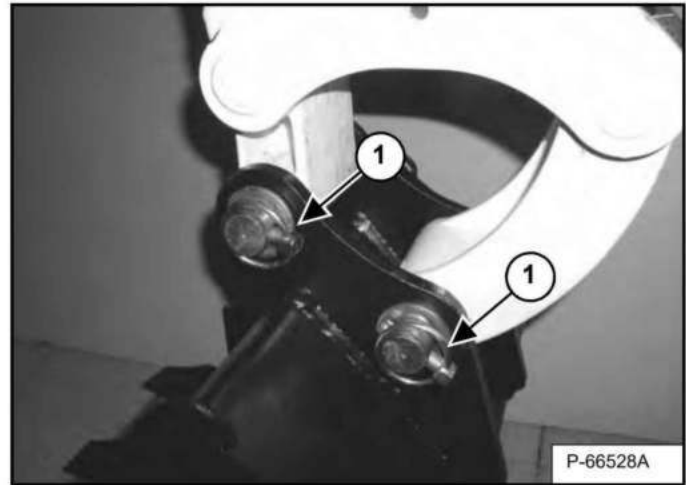

Install the two retainer pins (Item 1) [Figure 93]. Install grease in the grease fittings.

Removal

Park the excavator on a flat surface and lower the bucket fully.

Remove the two retainer pins (Item 1) [Figure 93].

Remove the washers and pins (Items 1 and 3) [Figure 92].

Do not damage the dust seals in the arm.

! WARNING

AVOID INJURY OR DEATH

Never use attachments or buckets which are not approved by Bobcat Company. Buckets and attachments for safe loads of specified densities are approved for each model. Unapproved attachments can cause injury or death.

W-2052-0907

OPERATING PROCEDURE

Inspect The Work Area

Before beginning operation, inspect the work area for unsafe conditions.

Look for sharp drop-offs or rough terrain. Have underground utility lines (gas, water, sewer, irrigation, etc.) located and marked. Work slowly in areas of underground utilities.

Remove objects or other construction material that could damage the excavator or cause personal injury.

Always check ground conditions before starting your work:

- Inspect for signs of instability such as cracks or settlement.
- Be aware of weather conditions that can affect ground stability.
- Check for adequate traction if working on a slope.

Basic Operating Instructions

When operating on a public road or highway, always follow local regulations. For example: A slow moving vehicle (SMV) sign, or direction signals can be required.

Run the engine at low idle speed to warm the engine and hydraulic system before operating the excavator.

IMPORTANT

Machines warmed up with moderate engine speed and light load have longer life.

I-2015-0284

New operators must operate the excavator in an open area without bystanders. Operate the controls until the excavator can be handled at an efficient and safe rate for all conditions of the work area.

Operating Near An Edge Or Water

Keep the excavator as far back from the edge as possible and the excavator tracks perpendicular to the edge so that if part of the edge collapses, the excavator can be moved back.

Always move the excavator back at any indication the edge can be unstable.

Lowering The Work Equipment (Engine STOPPED)

The hydraulic control levers control the movement of the boom, arm, bucket and upperstructure slew functions.

The console must be in the locked down position, and the key switch in the ON position.

Use the control lever to lower the boom.

Figure 94



The joystick lock switch disengages the hydraulic control functions from the joysticks when the console are raised [Figure 94].

NOTE: If the engine stops, the boom / bucket (attachments) can be lowered to the ground using hydraulic pressure in the accumulator.

The control console must be in the locked down position, and the key switch in the ON position.

Use the control lever to lower the boom.

Lower the control console to engage the hydraulic control functions of the joysticks [Figure 94].

Dealer Copy -- Not for Resale

OPERATING PROCEDURE (CONT'D)

Object Handling

Do not exceed the Rated Lift Capacity. (See Lift Chart (7206148) With Standard Arm on Page 143.) or (See Lift Chart (7206149) With Standard Arm and Additional Counterweight (Cont'd) on Page 147.) or (See Lift Chart (7206150) With Long Arm and Additional Counterweight on Page 149.)

WARNING

AVOID INJURY OR DEATH

Do not exceed rated lift capacity. Excessive load can cause tipping or loss of control.

W-2374-0500

Extend the bucket cylinder completely and lower the boom to the ground. Stop the engine.

Wrap the chain assembly around the bucket mounting plate.

Figure 95

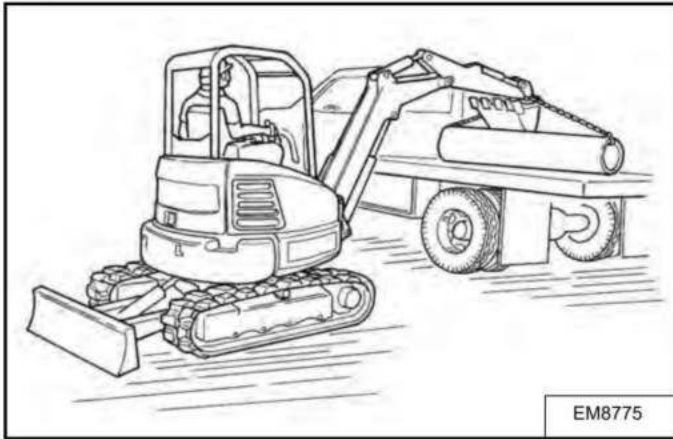

Make sure the load is evenly weighted and centered on the lifting chain, and is secured to prevent the load from shifting [Figure 95].

Lift and position the load. Once the load is in position and tension is removed from the lift chain (secondary lift system), remove the secondary lift system.

OPERATING PROCEDURE (CONT'D)

Using The Clamp

Figure 96

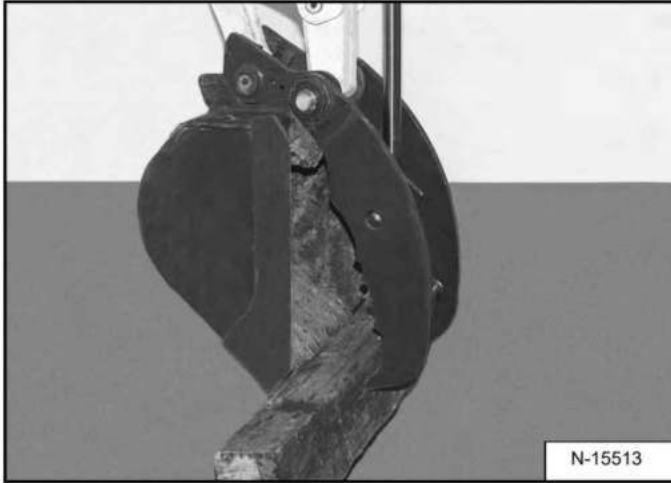

The optional lifting clamp attachment gives the excavator a wider range of use and mobility for debris removal [Figure 96].

The lifting clamp cylinder must be fully retracted when the machine is being used for excavating.

The lift capacities are reduced by 122 kg (270 lb) if the excavator is equipped with the optional lifting clamp.

When Using Primary Auxiliary Hydraulics To Activate Clamp

Engage auxiliary hydraulics. (See Auxiliary Hydraulics on Page 46.)

Figure 97

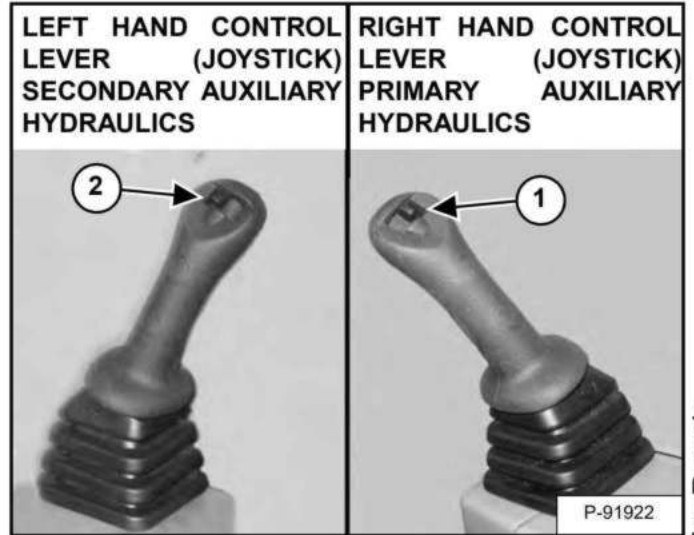

Move the switch (Item 1) [Figure 97] on the right control lever to the left to open the clamp. Move the switch to the right to close the clamp.

When Using Secondary Auxiliary Hydraulics To Activate Clamp

Engage secondary auxiliary hydraulics. (See Secondary Auxiliary Hydraulics on Page 47.)

Move the switch (Item 2) [Figure 97] on the left control lever to the right open the clamp. Move the switch to the left to close the clamp.

Dealer Copy -- Not for Resale

OPERATING PROCEDURE (CONT'D)

Excavating

Lower the blade to increase digging performance.

Figure 98

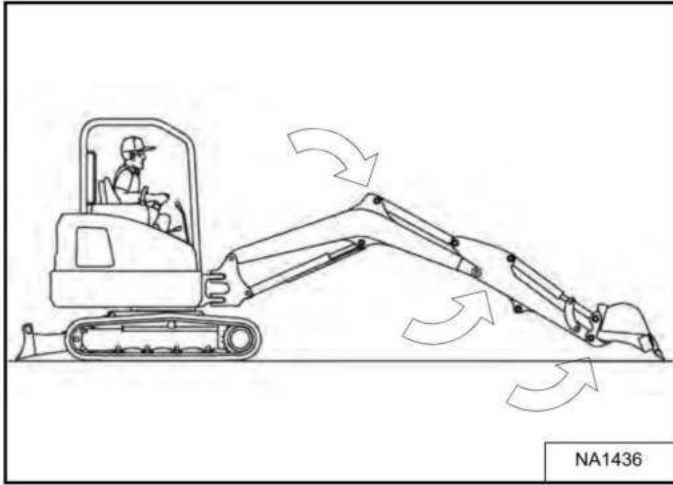

Extend the arm, lower the boom, and open the bucket [Figure 98].

Figure 99

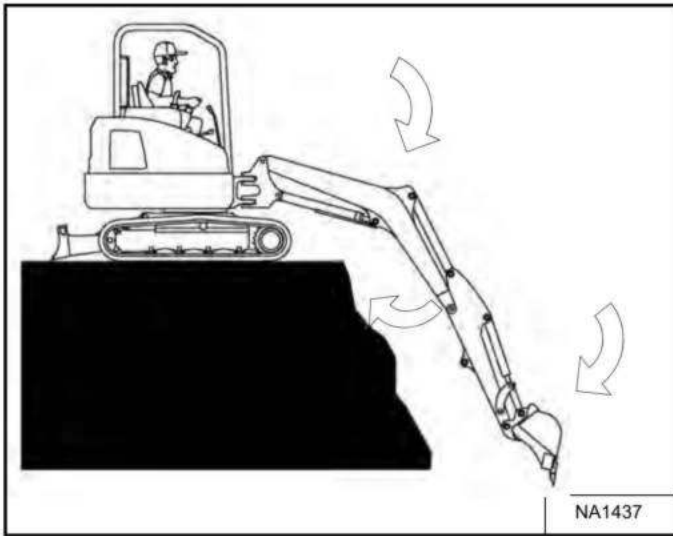

Retract the arm, while lowering boom and curling the bucket [Figure 99].

Figure 100

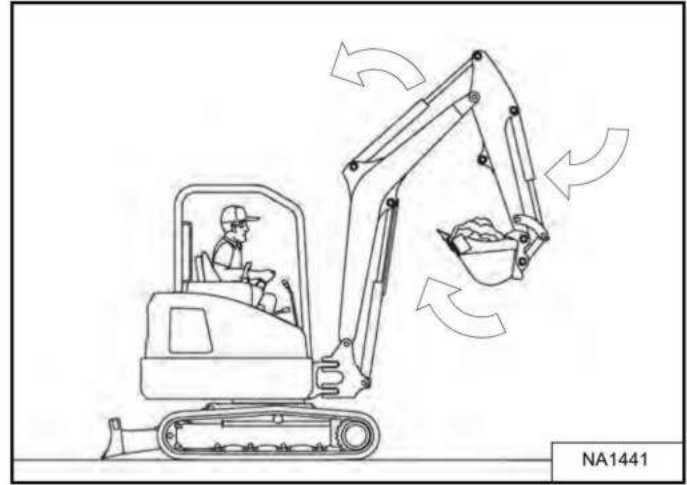

Raise the boom, retract the arm and curl the bucket [Figure 100].

Rotate the upperstructure.

NOTE: Do not allow the bucket teeth to contact the ground when slewing the upperstructure.

! WARNING

Keep all bystanders 6 m (20 ft) away from equipment when operating. Contact with moving parts, a trench cave-in or flying objects can cause injury or death.

W-2119-0910

! WARNING

AVOID INJURY OR DEATH

Check area to be excavated for overhead or underground electrical power lines. Keep a safe distance from electrical power lines.

LINE VOLTAGE	MINIMUM APPROACH DISTANCE
50 kV	At least 3 m (10 ft)
230 kV	At least 5 m (17 ft)
740 kV	At least 10 m (33 ft)

W-2757-0910

Dealer Copy -- Not for Resale

OPERATING PROCEDURE (CONT'D)

Excavating (Cont'd)

Figure 101

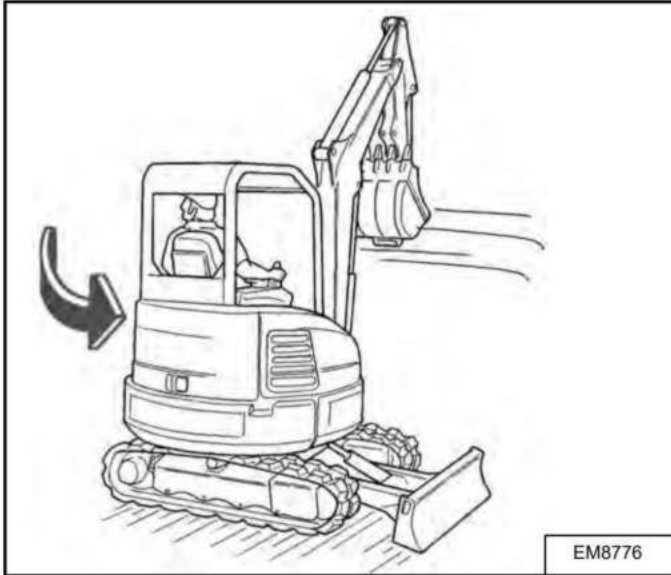

Look in the direction of rotation and make sure there are no bystanders in the work area before rotating the upperstructure [Figure 101].

Figure 102

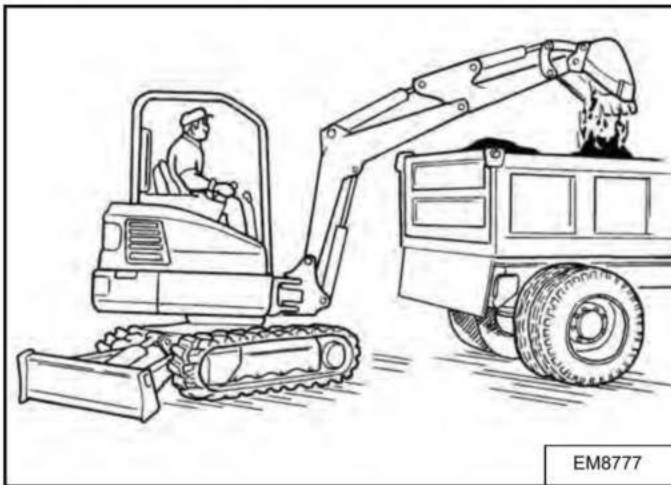

Extend the arm and uncurl the bucket to dump the material into a pile or truck [Figure 102].

IMPORTANT

Avoid operating hydraulics over relief pressure. Failure to do so will overheat hydraulic components.

I-2220-0503

Figure 103

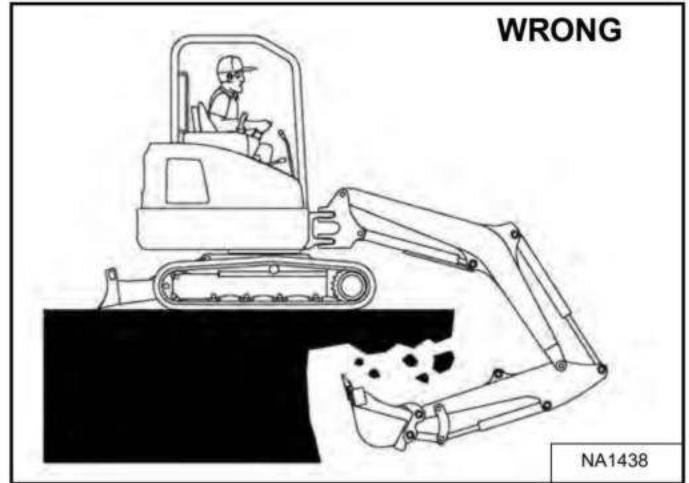

Do not dig under the excavator [Figure 103].

Do not use the bucket as a breaker or pile driver. It is better to excavate hard or rocky ground after breaking it with other equipment. This will reduce damage to the excavator.

Do not move the excavator while the bucket is in the ground.

Dig only by moving the boom and arm toward the excavator.

Do not back dig (digging by moving the boom and arm away from the excavator). Damage to the quick coupler and attachments can occur.

Dealer Copy -- Not for Resale

OPERATING PROCEDURE (CONT'D)

Boom Swing

Figure 104

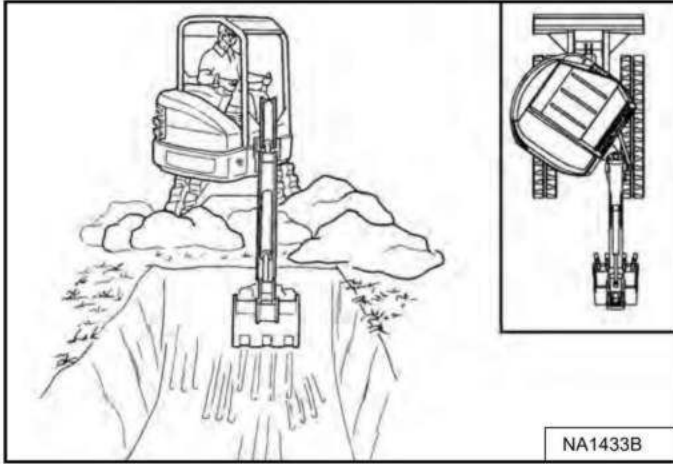

Figure 105

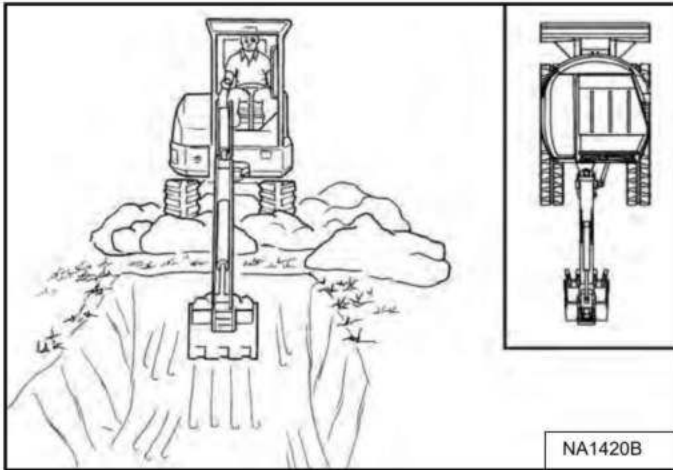
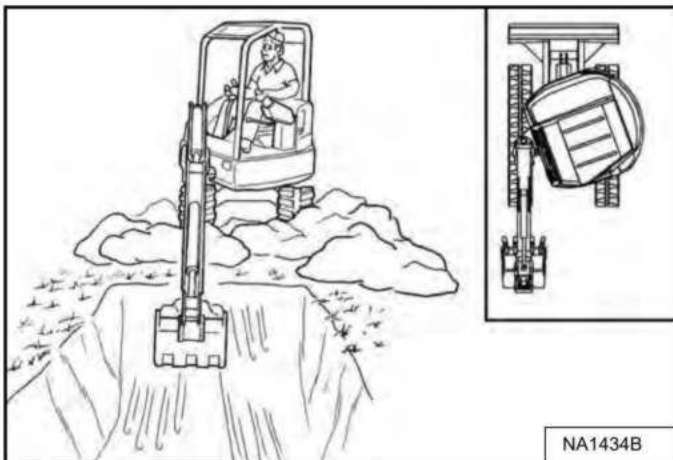

Figure 106



Slew the upperstructure, swing the boom to the right [Figure 104], center [Figure 105] and left [Figure 106] to dig a square hole the width of the machine without repositioning the excavator.

Figure 107



The boom swing allows the operator to offset the boom and dig close to buildings and other structures [Figure 107].

Backfilling

IMPORTANT

Avoid impacting objects with the blade. Damage to blade and undercarriage components may occur.

I-2256-0507

Figure 108



Use the blade to backfill the trench or hole after excavating [Figure 108].

Driving The Excavator

When operating on uneven ground, operate as slow as possible and avoid sudden changes in direction.

Avoid traveling over objects such as rocks, trees, stumps, etc.

When working on wet or soft ground, put planks on the ground to provide a solid base to travel on and prevent the excavator from getting stuck.

Figure 109

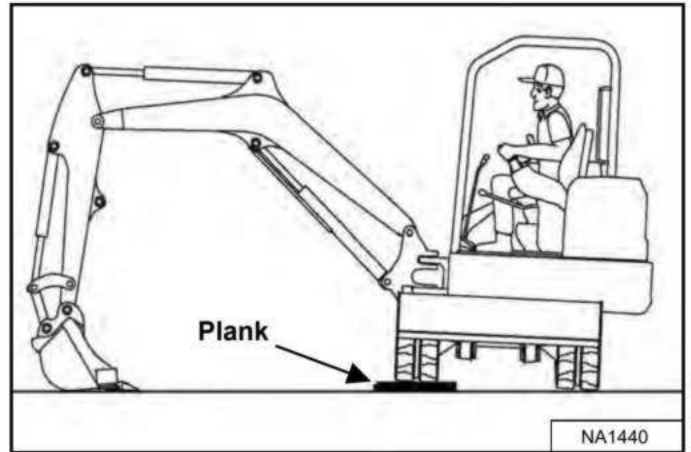

If one or both tracks have become stuck in soft or wet ground, raise one track at a time by turning the upperstructure and pushing the bucket against the ground [Figure 109].

Put planks under the tracks and drive the excavator to dry ground.

Figure 110

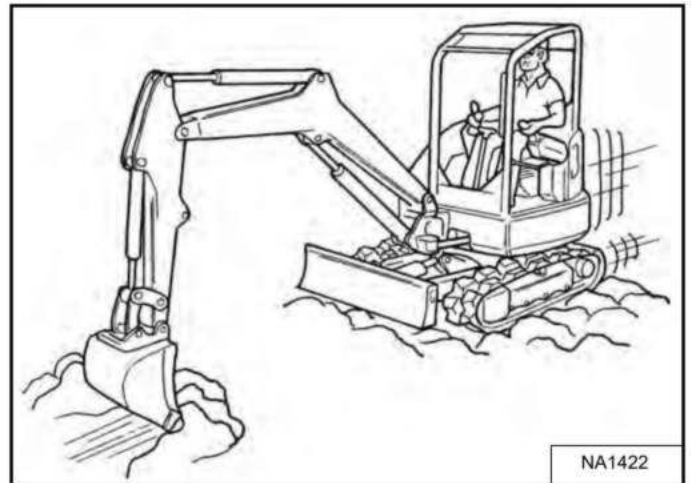

The bucket can also be used to pull the excavator. Raise the blade, extend the arm and lower the boom. Operate the boom and arm in a digging manner [Figure 110].

Dealer Copy : Not for Resale

OPERATING PROCEDURE (CONT'D)

Operating On Slopes

! WARNING

AVOID INJURY OR DEATH

- Do not travel across or up slopes that are over 15 degrees.
- Do not travel down or back up slopes that exceed 25 degrees.
- Look in the direction of travel.

W-2497-0304

When going down a slope, control the speed with the steering levers and the speed control dial gauge.

Figure 111

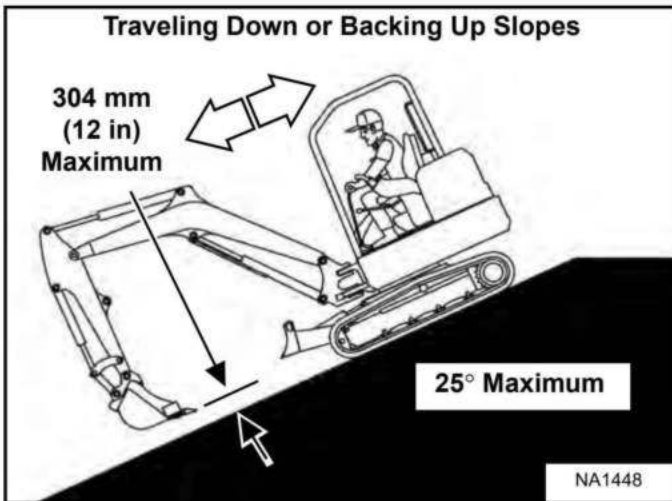

When going down grades that exceed 15 degrees, put the machine in the position shown, and run the engine slowly [Figure 111].

Operate as slow as possible and avoid sudden changes in lever direction.

Avoid traveling over objects such as rocks, trees, stumps, etc.

Stop the machine before moving the upper equipment controls. Never allow the blade to strike a solid object. Damage to the blade or hydraulic cylinder can result.

! WARNING

AVOID INJURY OR DEATH

- Avoid steep areas or banks that could break away.
- Keep boom centered and attachments as low as possible when traveling on slopes or in rough conditions. Look in the direction of travel.
- Always fasten seat belt.

W-2498-0304

Figure 112

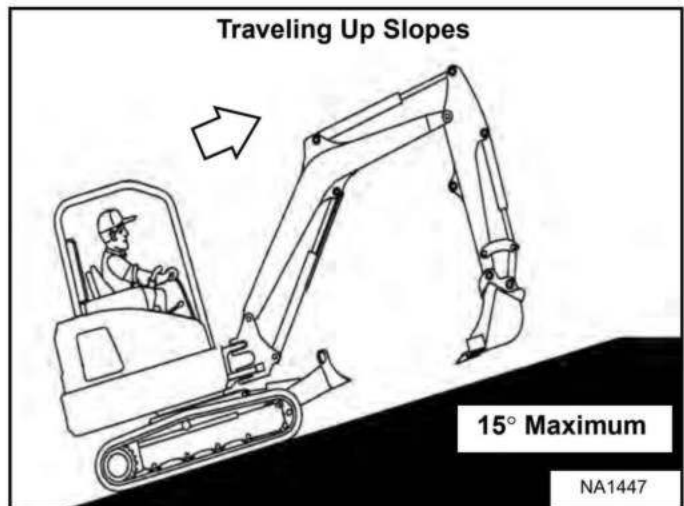
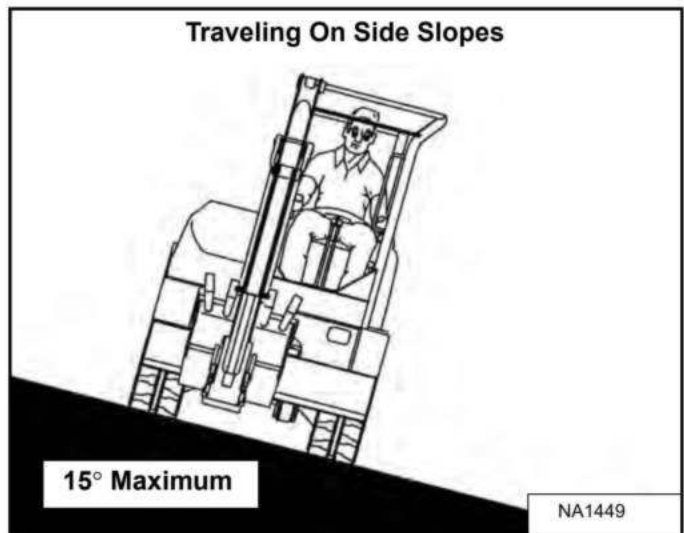

Figure 113



When traveling up slopes or on side slopes that are 15 degrees or less, position the machine as shown and run the engine slow [Figure 112] and [Figure 113].

Dealer Copy -- Not for Resale

OPERATING PROCEDURE (CONT'D)

Operating On Slopes (Cont'd)

Figure 114

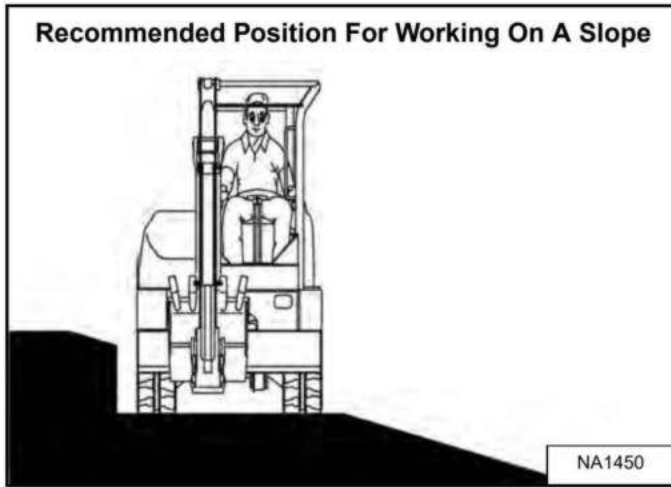

When operating on a slope, level the work area before beginning [Figure 114].

If this is not possible, the following procedures should be used:

Do not work on slopes which are over 15 degrees.

Use a slow work cycle.

Avoid working with the tracks across the slope. This will reduce stability and increase the tendency for the machine to slide. Position the excavator with the blade downhill and lowered.

Avoid swinging or extending the bucket more than necessary in a down hill direction. When you must swing the bucket downhill, keep the arm low and skid the bucket downhill.

When working with the bucket on the uphill side, keep the bucket as close to the ground as possible. Dump the spoil far enough away from the trench or hole to prevent the possibility of a cave in.

Figure 115

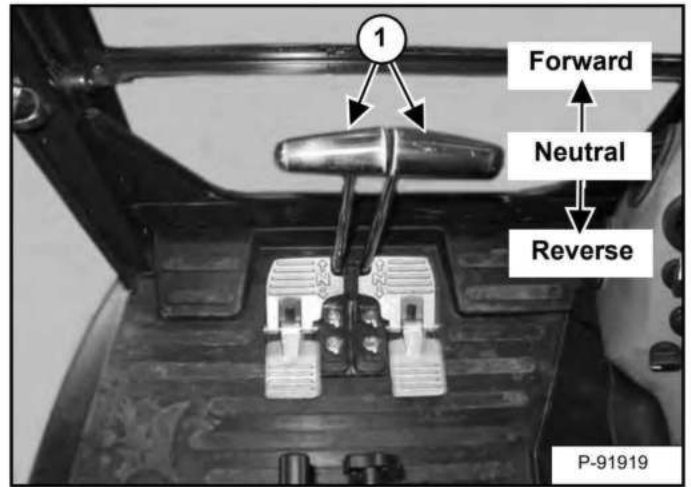

To brake the machine when going down a slope, move the steering levers (Item 1) [Figure 115] to the *NEUTRAL* position. This will engage the hydrostatic braking.

When the engine stops on a slope, move the steering levers to the neutral position. Lower the boom / bucket to the ground.

NOTE: If the engine stops, the boom / bucket (attachments) can be lowered to the ground using hydraulic pressure which is stored in the accumulator.

The console must be in the locked down position, and the key switch in the ON position.

Use the control lever to lower the boom.

Start the engine and resume operation.

Dealer Copy -- Not for Resale

OPERATING PROCEDURE (CONT'D)

Operating In Water

Mud and water should be removed from the machine before parking. In freezing temperatures, park the machine on boards or concrete to prevent the track or undercarriage from freezing to the ground and preventing machine movement.

Figure 116

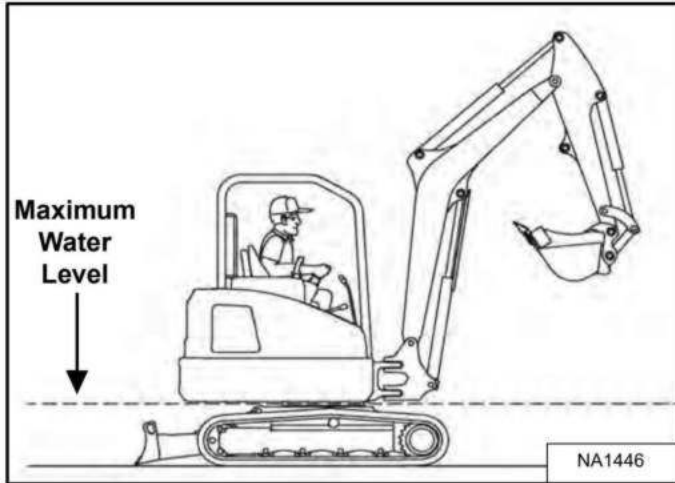

Do not operate or immerse the excavator in water higher than the bottom of the slew bearing **[Figure 116]**.

Grease the excavator when it has been operated or immersed in water for a period of time. Greasing forces the water out of the lubrication areas.

Water must be removed from the cylinder rods. If water freezes to the cylinder rod, the cylinder seals can be damaged when the rod is retracted.

OPERATING PROCEDURE (CONT'D)

Avoiding Track Damage

Mud and water should be removed from the machine before parking. In freezing temperatures, park the machine on boards or concrete to prevent the track or undercarriage from freezing to the ground and preventing machine movement.

Some Causes Of Track Damage:

Figure 117

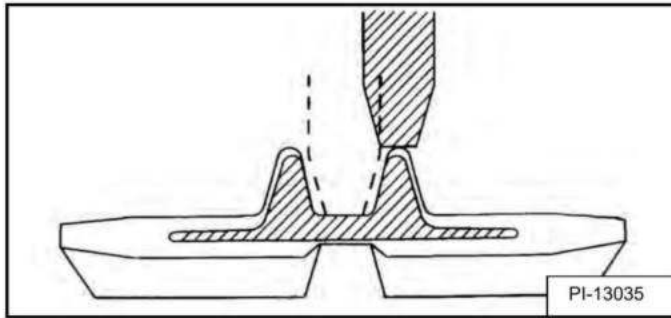

Incorrect track tension: When the rubber track is detracting, the idler or sprocket rides on the projections of the embedded metal **[Figure 117]** causing the embedded metal to be exposed to corrosion. (See TRACK TENSION on Page 117.)

If rubber track is clogged with stones or foreign objects, these can get wedged between the sprocket / rollers and cause detracting and track stress.

When moisture invades through cuts on the track, the embedded steel cords will corrode. The deterioration of the design strength can lead to the breaking of the steel cords.

Figure 118

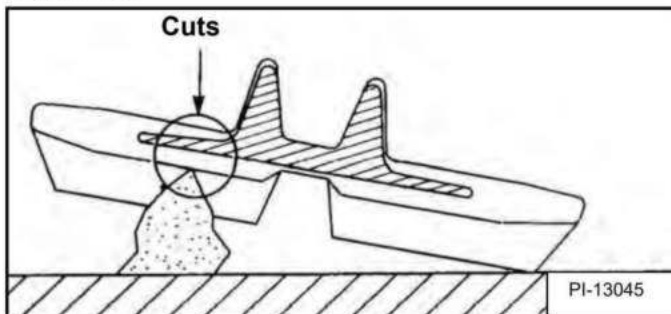

When rubber tracks drive over projections or sharp objects in the field, the concentrated forces applied cause cuts on the lug side rubber surface **[Figure 118]**. In case of making turns on projections, the lug side rubber surface will have an even higher chance to be cut. If the cuts run through the embedded steel cords, it might result in the steel cords' breakage due to their corrosion.

Avoid quick turns on bumpy and rocky fields.

Driving over sharp objects should be avoided. If this is impossible, do not make turns while driving over sharp objects.

Figure 119

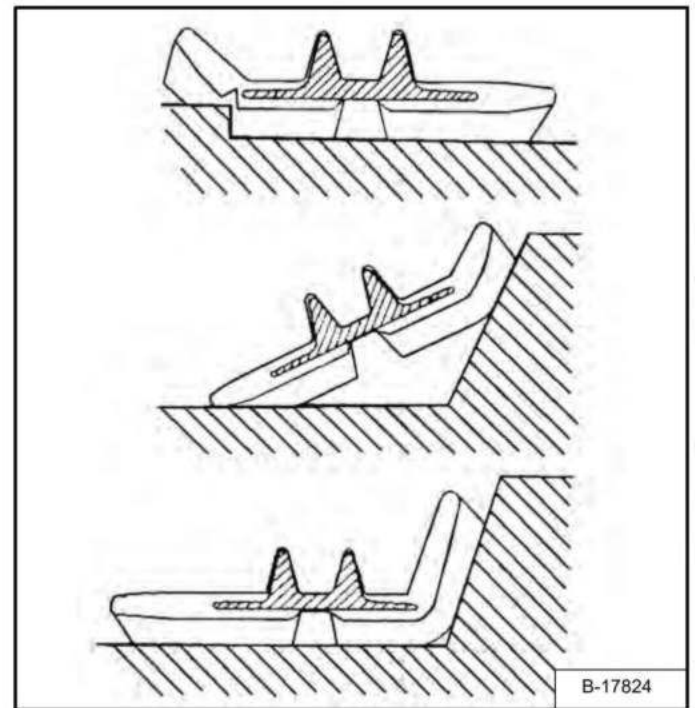

When rubber tracks drive over sharp projections, intensive stress is applied to the lug side rubber surface, especially at the edges of embedded metals, causing cracks and cuts in the area around the embedded metals **[Figure 119]**.

Avoid extensive stress applied to the lug root where metals are embedded. Operators should try to avoid driving over stumps and ridges.

Dealer Copy -- Not for Resale

TOWING THE EXCAVATOR

Procedure

There is not a recommended towing procedure for the excavators.

- The excavator can be lifted onto the transport vehicle.
- The excavator can be skidded a short distance for service (EXAMPLE: Move onto a transport vehicle) without damage to the hydraulic system. (The tracks will not turn.) There might be slight wear to the tracks when the excavator is skidded.
- The towing chain (or cable) must be rated at 1.5 times the weight of the excavator. (See Performance on Page 171.)

LIFTING THE EXCAVATOR

Procedure

Figure 120

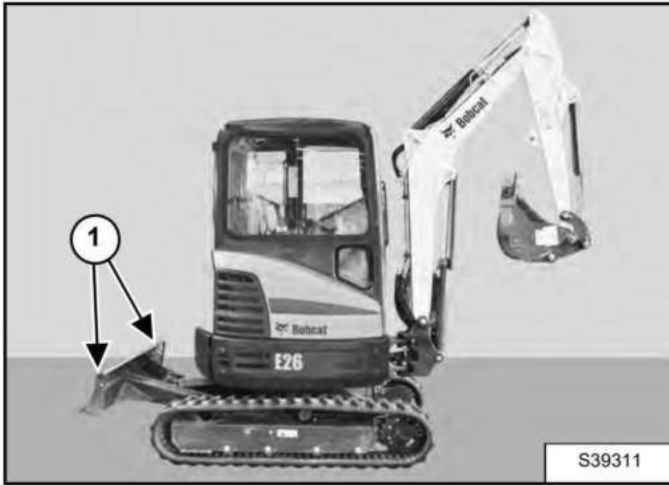

Fully extend the cylinders of the bucket, arm, and boom so that the excavator is in the position as shown [Figure 120].

Raise the blade all the way.

Put all the control levers in neutral.

WARNING

AVOID INJURY OR DEATH

- Use chains and lifting equipment with sufficient capacity for the weight of the excavator plus any added attachments.
- Maintain center of gravity and balance when lifting.
- Do not swing boom or upperstructure.
- Never lift with operator on machine.
- Never lift with the blade angled (if equipped).

W-2800-0709

Figure 121

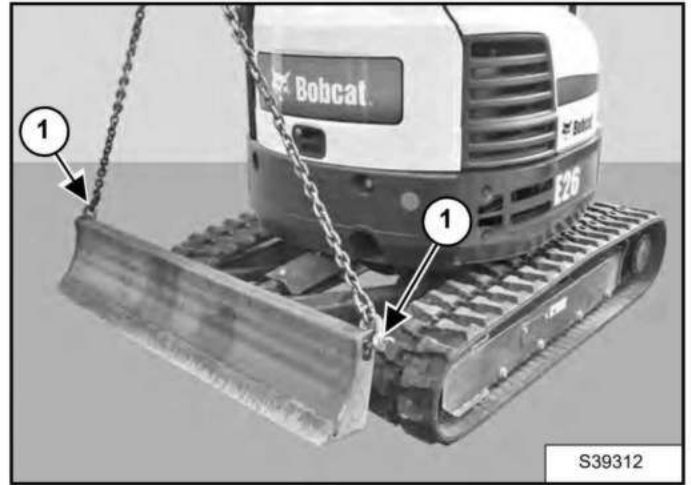
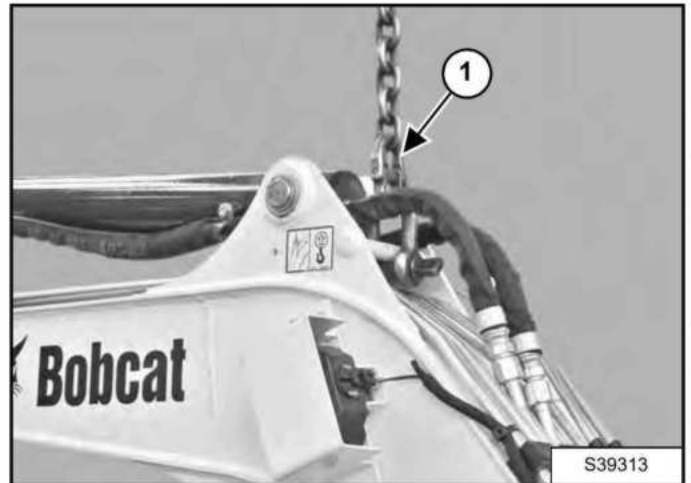

Figure 122



Fasten chains to the ends of the blade (Item 1) [Figure 120] and [Figure 121] and up to a lifting fixture above the canopy / cab. The lifting fixture must extend over the sides of the canopy / cab to prevent the chains from hitting the ROPS / TOPS.

Fasten a chain (Item 1) [Figure 122] from the rod to the lift fixture.

Dealer Copy -- Not for Resale

TRANSPORTING THE EXCAVATOR ON A TRAILER

Loading And Unloading

When transporting the machine, observe the rules, motor vehicle laws, and vehicle limit ordinances. Use a transport and towing vehicle of adequate length and capacity.

Secure the parking brakes and block the wheels of the transport vehicle.

Align the ramps with the center of the transport vehicle. Secure the ramps to the truck bed and be sure ramp angle does not exceed 15 degrees.

Use metal loading ramps with a slip resistant surface.

Use ramps that are the correct length and width and can support the weight of the machine.

The rear of the trailer must be blocked or supported when loading or unloading the machine to prevent the front of the transport vehicle from raising.

Determine the direction of the track movement before moving the machine (blade forward).

Disengage the auto idle feature and move the two speed travel to the low range position.

Figure 123



Move the machine forward onto the transport vehicle [Figure 123].

Do not change direction of the machine while it is on the ramps.

Lower the boom, arm, bucket, and blade to the transport vehicle.

Stop the engine and remove the key (if equipped).

Put blocks at the front and rear of the tracks.

Fastening

Figure 124

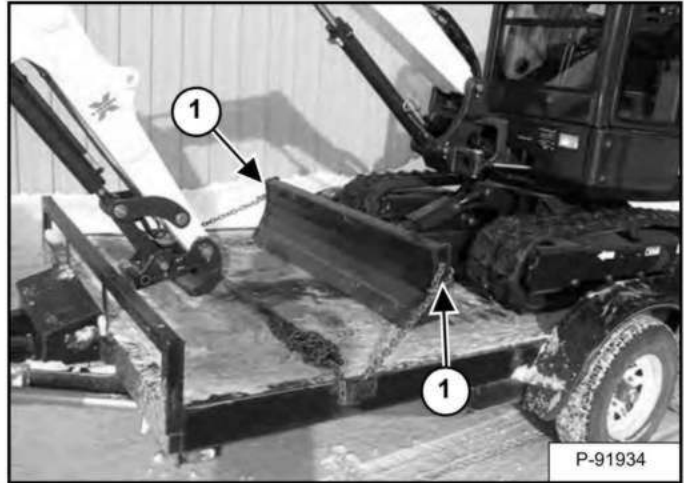

Figure 125



Fasten chains to the front corners of the blade (Item 1) [Figure 124] and to the tie down loop at both sides of the track frame (Item 1) [Figure 125] to prevent it from moving when going up or down slopes or during sudden stops.

Use chain binders to tighten the chains and then safely tie the chain binder levers to prevent loosening.

WARNING

AVOID SERIOUS INJURY OR DEATH

Adequately designed ramps of sufficient strength are needed to support the weight of the machine when loading onto a transport vehicle. Wood ramps can break and cause personal injury.

W-2058-0807

PREVENTIVE MAINTENANCE

MAINTENANCE SAFETY85
SERVICE SCHEDULE87
Chart87
CONTROL CONSOLE LOCKOUTS88
Inspection And Maintenance88
SEAT BELT89
Inspection And Maintenance89
MOTION ALARM SYSTEM90
Description90
Inspecting90
Adjusting Switch Position91
TAILGATE92
Opening And Closing92
Adjusting The Latch92
RIGHT SIDE COVER93
Opening And Closing93
CAB FILTERS94
Cleaning And Maintenance94
AIR CLEANER SERVICE95
Daily Check95
Replacing The Filter Elements95
FUEL SYSTEM97
Fuel Specifications97
Biodiesel Blend Fuel97
Filling The Fuel Tank98
Fuel Filter99
Draining The Fuel Tank99
Removing Air From The Fuel System	100
ENGINE LUBRICATION SYSTEM	101
Checking And Adding Engine Oil	101
Engine Oil Chart	101
Removing And Replacing Oil And Filter	102
ENGINE COOLING SYSTEM	103
Cleaning	103
Checking Level	104
Removing And Replacing Coolant	105

ELECTRICAL SYSTEM	106
Description	106
Fuse And Relay Location / Identification	106
Battery Maintenance	108
Using A Booster Battery (Jump Starting)	108
Removing And Installing The Battery	110
HYDRAULIC SYSTEM	111
Checking And Adding Hydraulic Oil	111
Hydraulic / Hydrostatic Fluid Chart	112
Removing And Replacing The Hydraulic Filters	112
Removing And Replacing The Hydraulic Oil	114
SPARK ARRESTOR MUFFLER	115
Cleaning Procedure	115
SPARK ARRESTOR MUFFLER	116
TRACK TENSION	117
Checking Tension	117
Adjusting Tension	118
TRAVEL MOTOR	119
Checking And Adding Oil	119
Removing And Replacing Oil	119
ALTERNATOR AND FAN BELT	120
Belt Adjustment	120
Belt Replacement	120
AIR CONDITIONING COMPRESSOR BELT	121
Belt Adjustment	121
Belt Replacement	121
X-CHANGE™	121
Inspection And Maintenance	121
TRACK ROLLER AND IDLER LUBRICATION	122
Procedure	122
BUCKET	122
Bucket Teeth Removal And Installation	122
LUBRICATION OF THE HYDRAULIC EXCAVATOR	123
Lubrication Locations	123
PIVOT PINS	126
Inspection And Maintenance	126

EXCAVATOR STORAGE AND RETURN TO SERVICE	127
Storage	127
Return To Service	127

Dealer Copy -- Not for Resale



Bobcat®

Dealer Copy -- Not for Resale

MAINTENANCE SAFETY



WARNING

Instructions are necessary before operating or servicing machine. Read and understand the Operation & Maintenance Manual, Operator's Handbook and signs (decals) on machine. Follow warnings and instructions in the manuals when making repairs, adjustments or servicing. Check for correct function after adjustments, repairs or service. Untrained operators and failure to follow instructions can cause injury or death.

W-2003-0807



Safety Alert Symbol: This symbol with a warning statement, means: "Warning, be alert! Your safety is involved!" Carefully read the message that follows.

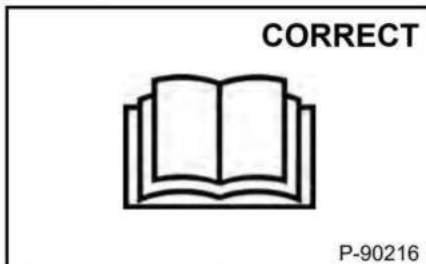

P-90216

- Never service the Bobcat Compact Excavator without instructions.

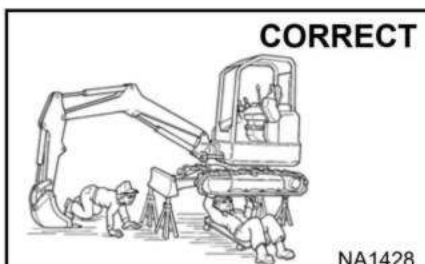

NA1428

- Use the correct procedure to lift and support the excavator.

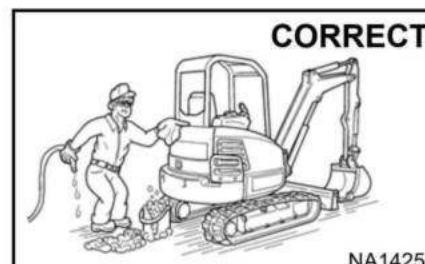

NA1425

- Cleaning and maintenance are required daily.

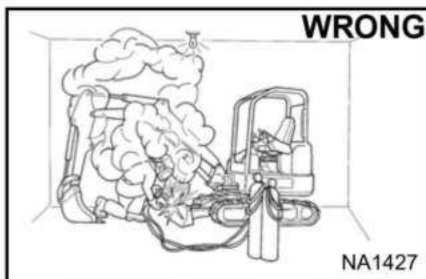

NA1427

- Have good ventilation when welding or grinding painted parts.
- Wear dust mask when grinding painted parts. Toxic dust and gas can be produced.

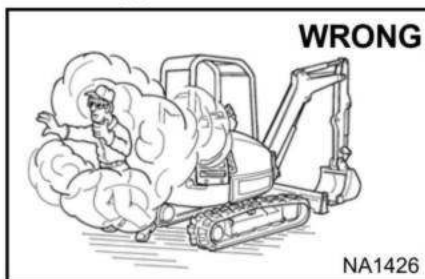

NA1426

- Vent exhaust to outside when engine must be run for service.
- Exhaust system must be tightly sealed. Exhaust fumes can kill without warning.

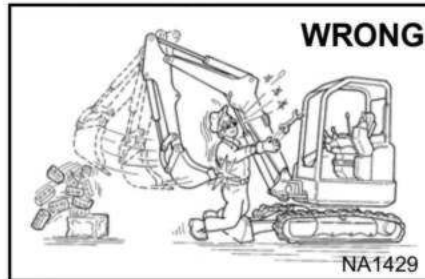

NA1429

- Always lower the bucket and blade to the ground before doing any maintenance.
- Never modify equipment or add attachments not approved by Bobcat Company.

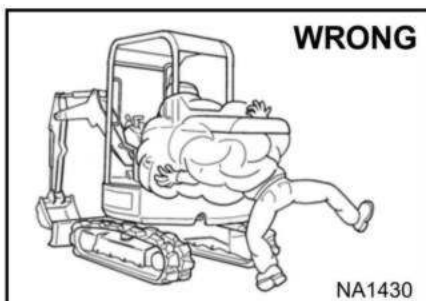

NA1430

- Stop, cool and clean engine of flammable materials before checking fluids.
- Never service or adjust machine with the engine running unless instructed to do so in the manual.
- Avoid contact with leaking hydraulic oil or diesel fuel under pressure. It can penetrate the skin or eyes.
- Never fill fuel tank with engine running, while smoking, or when near open flame.

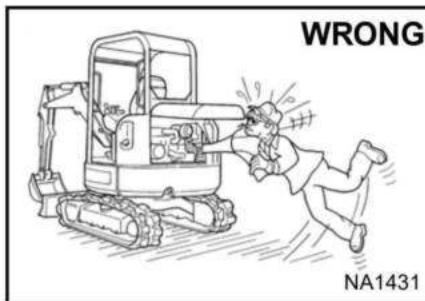

NA1431

- Keep body, jewelry and clothing away from moving parts, electrical contact, hot parts and exhaust.
- Wear eye protection to guard from battery acid, compressed springs, fluids under pressure and flying debris when engines are running or tools are used. Use eye protections approved for type of welding.
- Keep tailgate closed except for service. Close and latch tailgate before operating the excavator.



B-19798

- Lead-acid batteries produce flammable and explosive gases.
- Keep arcs, sparks, flames and lighted tobacco away from batteries.
- Batteries contain acid which burns eyes or skin on contact.
- Wear protective clothing. If acid contacts body, flush well with water. For eye contact flush well and get immediate medical attention.

Maintenance procedures which are given in the Operation & Maintenance Manual can be performed by the owner / operator without any specific technical training. Maintenance procedures which are **not** in the Operation & Maintenance Manual must be performed **ONLY BY QUALIFIED BOBCAT SERVICE PERSONNEL**. Always use genuine Bobcat replacement parts. The Service Safety Training Course is available from your Bobcat dealer.

MSW38-0409

Dealer Copy -- Not for Resale



Bobcat®

Dealer Copy -- Not for Resale

SERVICE SCHEDULE

Chart

Maintenance work must be done at regular intervals. Failure to do so will result in excessive wear and early failures. The service schedule is a guide for correct maintenance of the Bobcat excavator.

 <b style="font-size: 24pt; margin-left: 10px;">WARNING	<p>Instructions are necessary before operating or servicing machine. Read and understand the Operation & Maintenance Manual, Operator's Handbook and signs (decals) on machine. Follow warnings and instructions in the manuals when making repairs, adjustments or servicing. Check for correct function after adjustments, repairs or service. Untrained operators and failure to follow instructions can cause injury or death.</p> <p style="text-align: right; font-size: 10pt;">W-2003-0807</p>
--	---

SERVICE SCHEDULE		HOURS					
ITEM	SERVICE REQUIRED	8-10	50	100	250	500	[4] 1000
Engine Coolant	Check coolant level. Add premixed coolant as needed.						
Engine Oil	Check the engine oil level and add as needed.						
Hydraulic Oil, Hoses and Tubelines, Reservoir Breather Cap	Check the hydraulic oil level and add as needed. Check for damage and leaks. Repair or replace as needed.						
Engine Air Filter and Air System	Check condition indicator and empty dust cup as needed. Check air system for leaks.						
Tracks	Check and adjust track tension as needed.						
Indicators and Lights	Check for correct operation of all indicators and lights.						
Horn and Motion Alarm	Check for correct operation and repair as needed.	[1]					
Operator Canopy / Cab	Check condition. Check mounting hardware.						
Seat Belt	Check condition. Check mounting hardware.						
Safety Signs (Decals)	Check for damaged signs (decals). Replace any signs that are damaged.						
Pivot Points	Grease all machinery pivot points.						
Cab / Heater Air Filters	Clean the filters as needed.	[1]					
Console Lockout	Check console lockout for proper operation.						
X-Change	Lubricate and inspect for damage or loose parts.	[1]					
Slew Circle and Pinion	Grease two fittings		[2]				
Fuel Tank and Filter	Drain water and sediment from fuel tank and fuel filter.						
Battery	Check battery, cables, connections and electrolyte level. Add distilled water as needed.						
Alternator Belt	Check condition and tension. Adjust or replace as needed.		[3]				
Fuel Filter	Replace fuel filter.						
Travel Motor	Check oil level in both motors.						
Engine Oil and Filter	Replace oil and filter.		[3]				
Radiator, Oil Cooler, A/C Condenser	Clean debris from the radiator fins.					[1]	
Hydraulic Filter, Case Drain Filter and Reservoir Breather	Replace the hydraulic filter, case drain filter and reservoir breather.		[3]				
Alternator and Starter	Check the alternator and starter connections.		[3]				
Air Compressor Belt	Check condition and replace as needed.		[1], [3]				
Engine Valves	Check and adjust the engine valve clearance.						
Hydraulic System	Replace the hydraulic oil and filters. Clean the reservoir.						
Travel Motor	Replace the lubricant in both travel motors.		[3]				
Engine Coolant	Drain and flush the cooling system. Replace the coolant.						Every 2 years

[1] If Equipped.

[2] Service every 10 hours when operating in water.

[3] Service at the first 50 hours, then as scheduled.

[4] Or every 12 months.

Dealer Copy -- Not for Resale

CONTROL CONSOLE LOCKOUTS

Inspection And Maintenance

Figure 126

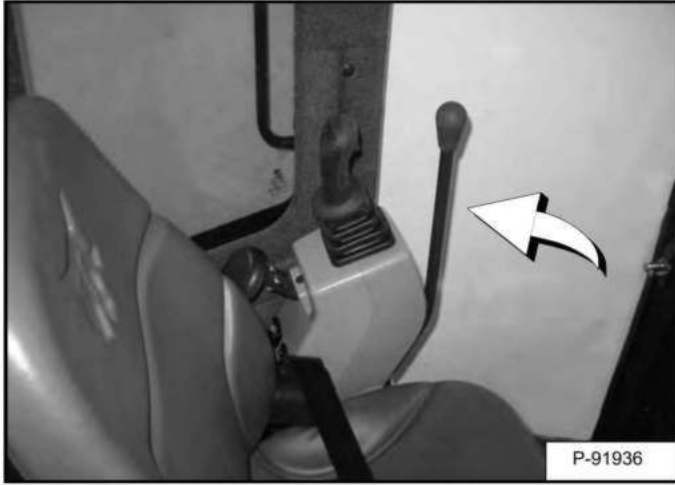

When the left console is raised **[Figure 126]**, the hydraulic control levers (joysticks) and traction system must not function.

Sit in the operator's seat, fasten the seat belt and start the engine.

Raise the left console **[Figure 126]**.

Move the joystick control levers. There should be no movement of the boom, arm, slew or bucket.

Move the steering control levers. There should be no movement of the excavator tracks.

Service the system if these controls do not deactivate when the left control console is raised. (See your Bobcat dealer for service.)

SEAT BELT

Inspection And Maintenance

WARNING

Failure to properly inspect and maintain the seat belt can cause lack of operator restraint resulting in serious injury or death.

W-2466-0703

Check the seat belt daily for correct function.

Inspect the seat belt system thoroughly at least once each year or more often if the machine is exposed to severe environmental conditions or applications.

Any seat belt system that shows cuts, fraying, extreme or unusual wear, significant discolorations due to ultraviolet UV exposure, dusty / dirty conditions, abrasion to the seat belt webbing, or damage to the buckle, latch plate, retractor (if equipped), hardware or any other obvious problem should be replaced immediately.

Figure 127

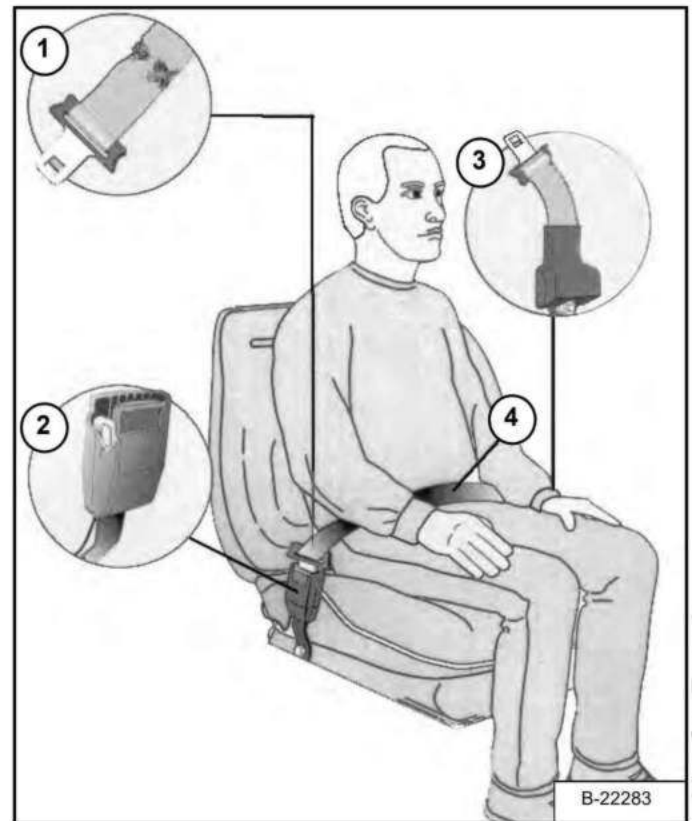

The items below are referenced in [Figure 127].

1. Check the webbing. If the system is equipped with a retractor, pull the webbing completely out and inspect the full length of the webbing. Look for cuts, wear, fraying, dirt and stiffness.
2. Check the buckle and latch for correct operation. Make sure latch plate is not excessively worn, deformed or buckle is not damaged or casing broken.
3. Check the retractor web storage device (if equipped) by extending webbing to determine if it looks correct and that it spools out and retracts webbing correctly.
4. Check webbing in areas exposed to ultraviolet (UV) rays from the sun or extreme dust or dirt. If the original color of the webbing in these areas is extremely faded and / or the webbing is packed with dirt, the webbing strength can have deteriorated.

See your Bobcat dealer for seat belt system replacement parts for your machine.

Dealer Copy -- Not for Resale

MOTION ALARM SYSTEM

Description

This excavator can be equipped with a motion alarm system. The motion alarm will sound when the operator moves the travel control levers in either the forward or reverse direction. Slight movement of the steering levers in either the forward or reverse direction is required with hydraulic components before the motion alarm will sound.

Inspecting

Figure 128



Figure 129

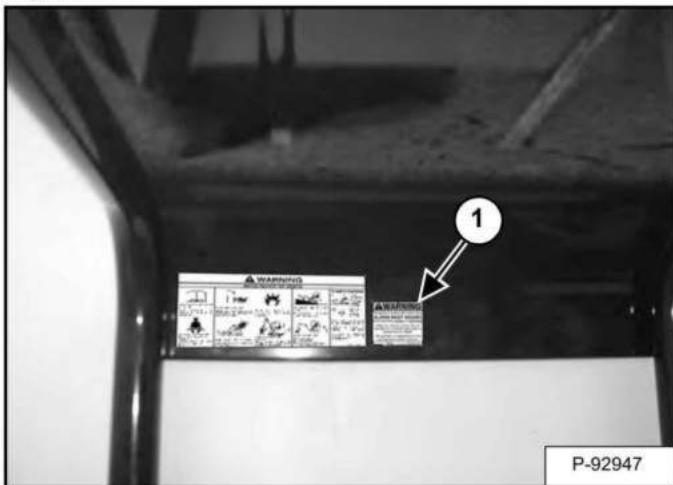

Inspect for damaged or missing motion alarm decal (Item 1) [Figure 128] (cab machine) or (Item 1) [Figure 129] (canopy machine). Replace if required.

NOTE: The excavator will need to be moved slightly in both the forward and reverse direction to test the motion alarm. Keep all bystanders away from machine during test.

! WARNING

AVOID INJURY OR DEATH

When an engine is running in an enclosed area, fresh air must be added to avoid concentration of exhaust fumes. If the engine is stationary, vent the exhaust outside. Exhaust fumes contain odorless, invisible gases which can kill without warning.

W-2050-0807

Sit in the operator's seat and fasten the seat belt. Start the engine. (See PRE-STARTING PROCEDURE on Page 52.)

Move the travel control levers (one lever at a time) in the forward direction. The motion alarm must sound. Move the travel control levers (one lever at a time) in the reverse direction. The motion alarm must sound.

Figure 130



Slightly move both travel control levers in the forward direction (until the machine is slowly moving forward) and then press the motion alarm cancel switch (Item 1) [Figure 130]. The motion alarm will shut off. With the machine still moving forward, move one of the levers to the neutral position, the motion alarm must sound.

Slightly move both travel control levers in the reverse direction (until the machine is slowly moving backward) and then press the motion alarm cancel switch (Item 1) [Figure 130] (the switch icon will be illuminated when the motion alarm is deactivated). The motion alarm will shut off. With the machine still moving backward, move one of the levers to the neutral position, the motion alarm must sound.

Return both levers to neutral and turn excavator key to OFF position. Exit the excavator. (See STOPPING THE ENGINE AND LEAVING THE EXCAVATOR on Page 59.)

MOTION ALARM SYSTEM (CONT'D)

Inspecting (Cont'd)

The motion alarm is mounted to the bottom rear of the excavator. (To the front of the engine oil pan.)

Figure 131

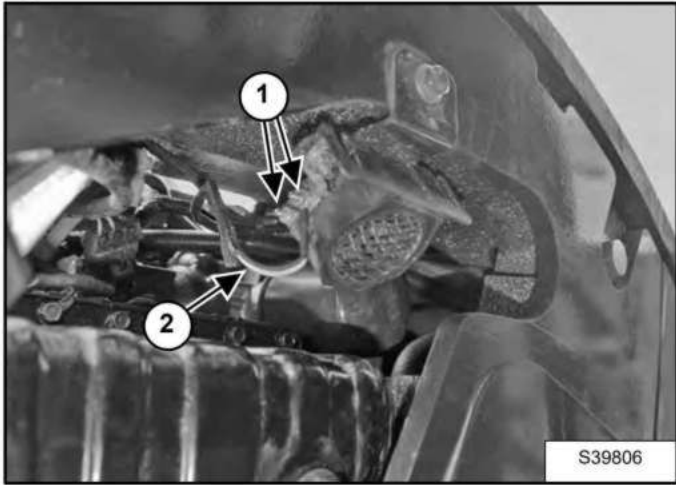

Inspect the motion alarm electrical connections (Item 1), wire harness (Item 2) [Figure 131] and motion alarm switch (Item 2) [Figure 132] for tightness and damage. Repair or replace any damaged components.

If the motion alarm switch requires adjustment, see the following information.



**This machine is equipped with a motion alarm.
ALARM MUST SOUND!
when operating forward or backward.**

Failure to maintain a clear view in the direction of travel could result in serious injury or death.

The operator is responsible for the safe operation of this machine.

W-2786-0309

Adjusting Switch Position

The motion alarm switch (Item 1) [Figure 132] is located in the travel control valve located under the floor plate. Remove the floor mat and the floor plate. (See the Service Manual for the correct procedure.)

Remove the travel levers.

Figure 132

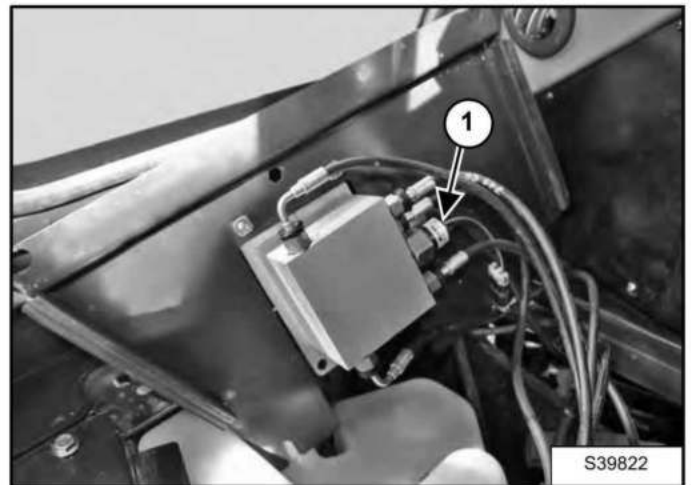

The switch (Item 1) [Figure 132] is non-adjustable. It must be fully installed into the travel control valve housing and tightened. Tighten the switch to 18 - 20 N•m (13 - 15 ft-lb).

Inspect the motion alarm system for proper function after switch replacement.

Dealer Copy -- Not for Resale

TAILGATE

Opening And Closing

! WARNING

AVOID INJURY OR DEATH

Never service or adjust the machine when the engine is running unless instructed to do so in the manual.

W-2012-0497

! WARNING

Keep the rear door closed when operating the machine. Failure to do so could seriously injure a bystander.

W-2020-1285

Figure 133



Pull the latch (Item 1) [Figure 133] and open the tailgate.

Push firmly to close the tailgate.

NOTE: The tailgate can be locked using the start key.

Adjusting The Latch

Figure 134

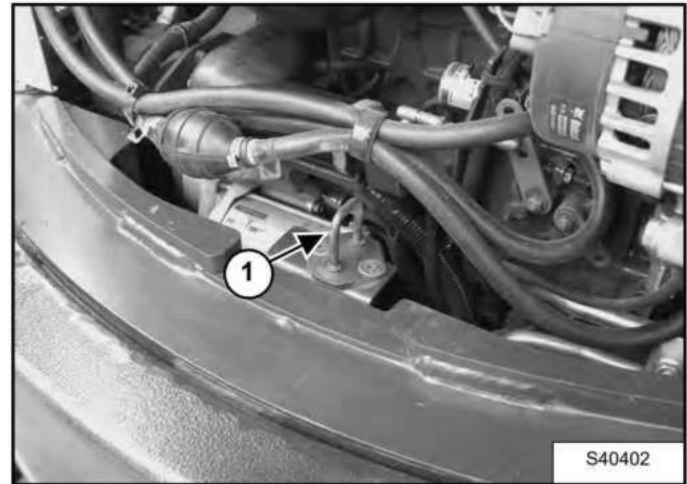

The tailgate latch (Item 1) [Figure 134] can be adjusted by loosening the two bolts, moving the latch, and tightening the two bolts.

Close the tailgate before operating the excavator.

RIGHT SIDE COVER

Opening And Closing

Figure 135

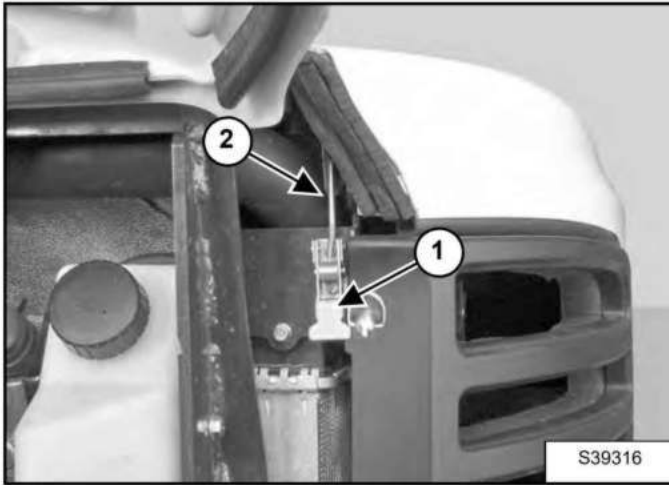

Open the tailgate to access the right side cover latch (Item 1) [Figure 135].

Pull up the lever (Item 1) and remove the latch (Item 2) [Figure 135] from the latch post.

Figure 136

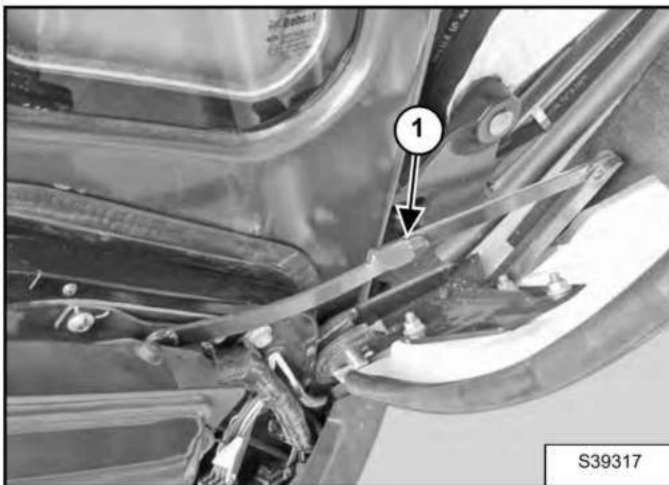

Raise the right side cover and rotate forward until it is held open by the retainer (Item 1) [Figure 136].

To close the right side cover, lift up on the retainer (Item 1) [Figure 136] while raising the right side cover. Rotate the cover back until it is in the fully closed position. Secure the right side cover with the latch (Item 2) and lever (Item 1) [Figure 135].

CAB FILTERS

Cleaning And Maintenance

The recirculation filter and the fresh air filter must be cleaned regularly. (See SERVICE SCHEDULE on Page 87.)

The recirculation filter is located to the right of the operator seat and the fresh air filter is located under the right side cover.

Recirculation Filter

Figure 137

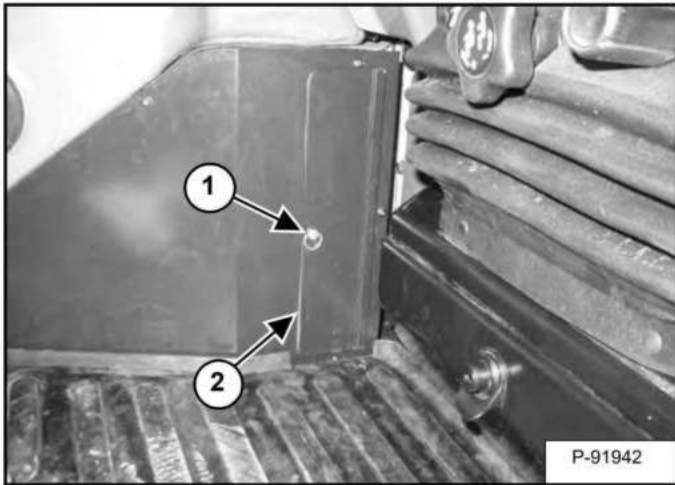

Turn the fastener (Item 1) 90° turn and open the cover (Item 2) [Figure 137].

Figure 138

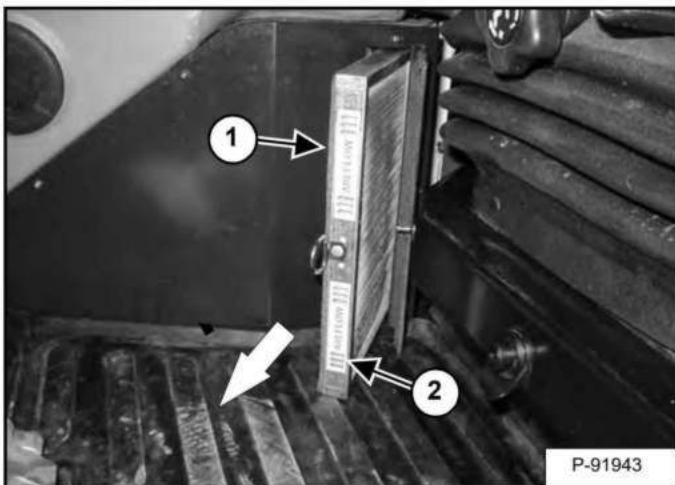

Pull the filter (Item 1) [Figure 138] out of the heater housing.

Use low air pressure to clean the filter. Replace the filter when very dirty.

Installation: Install the filter with the arrows that indicate air flow direction (Item 2) [Figure 138] pointing toward the heater housing.

Fresh Air Filter

Figure 139

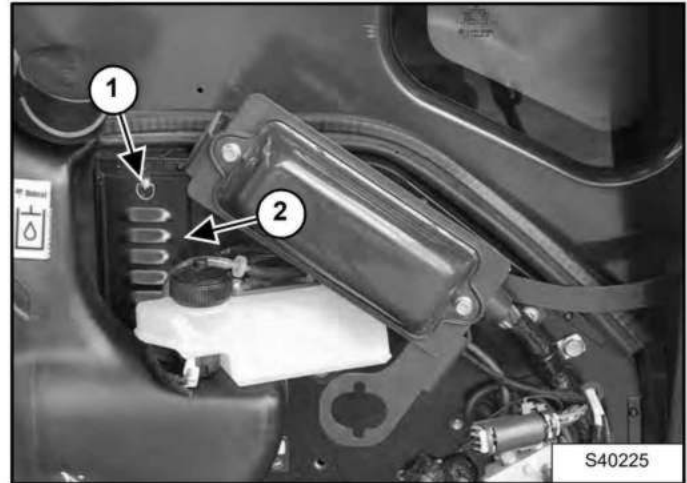

Open the right side cover. (See Opening And Closing on Page 93.)

Turn the fastener (Item 1) 90° and remove the cover (Item 2) [Figure 139].

Figure 140

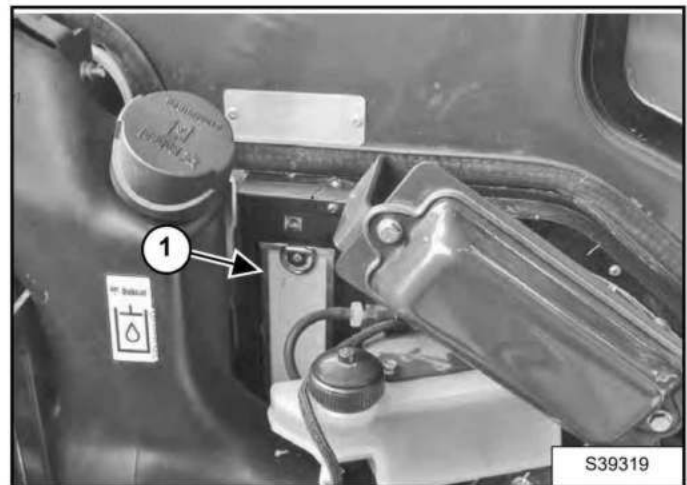

Pull the filter (Item 1) [Figure 140] out of the housing.

Use low air pressure to clean the filter. Replace the filter when very dirty.

AIR CLEANER SERVICE

See the service schedule for the correct service interval. (See SERVICE SCHEDULE on Page 87.)

Daily Check

Figure 141

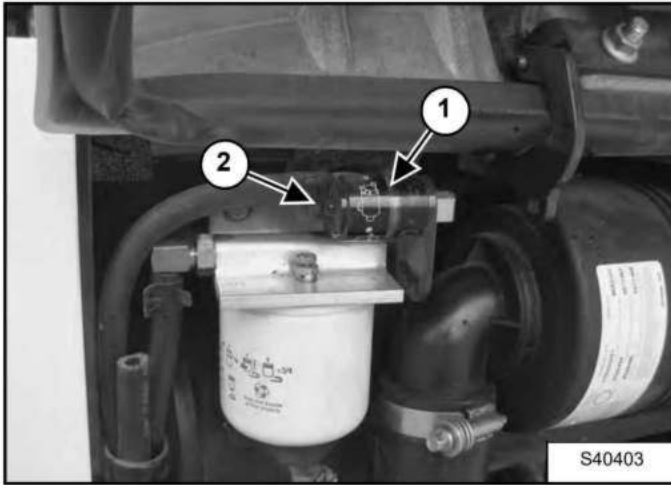

Check the condition indicator (Item 1) [Figure 141]. If the red ring shows in the condition indicator, the filter needs to be replaced.

Replace the inner filter every third time the outer filter is replaced or as indicated.

Replacing The Filter Elements

Outer Filter

Figure 142

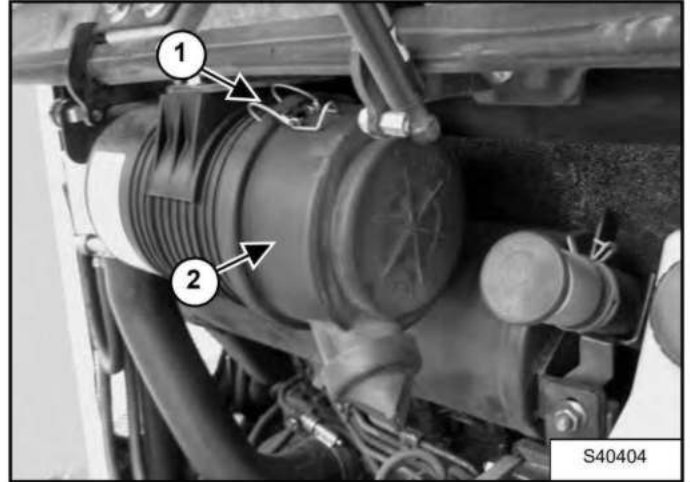

Open the two latches (Item 1) [Figure 142] and remove the dust cover (Item 2) [Figure 142].

Figure 143

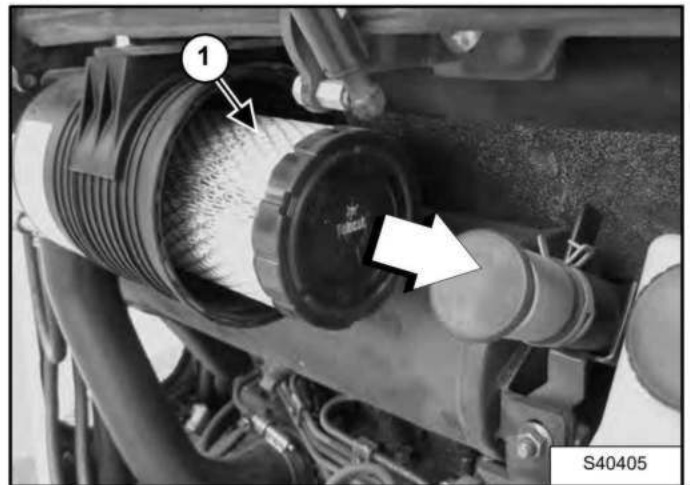

Pull the outer filter (Item 1) [Figure 143] from the air cleaner housing.

Check the housing for damage.

Clean the housing and the seal surface. DO NOT use compressed air.

Install a new filter.

Dealer Copy -- Not for Resale

AIR CLEANER SERVICE (CONT'D)

Replacing The Filter Elements (Cont'd)

Figure 144

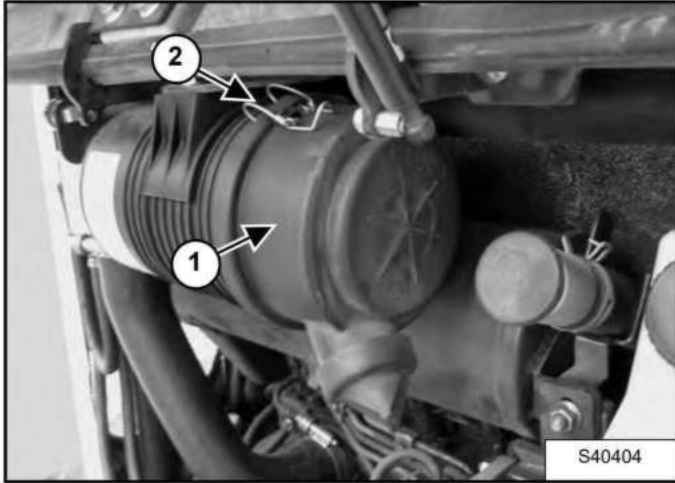

Install the dust cover (Item 1) and secure the two latches (Item 2) [Figure 144].

Check the air intake hose and the air cleaner housing for damage. Make sure all connections are tight.

After the outer filter has been replaced, press the button (Item 2) [Figure 141] on the end of the condition indicator and start the engine. Run at full rpm, then reduce engine speed and stop the engine. If the red ring (Item 1) [Figure 141] shows in the condition indicator, replace the inner filter.

Inner Filter

Only replace the inner filter under the following conditions:

- Replace the inner filter every *third* time the outer filter is replaced.
- After the outer filter has been replaced, press the button (Item 2) [Figure 141] on the condition indicator and start the engine. Run at full rpm, then reduce engine speed and stop the engine. If the red ring shows in the condition indicator, replace the inner filter.

Figure 145

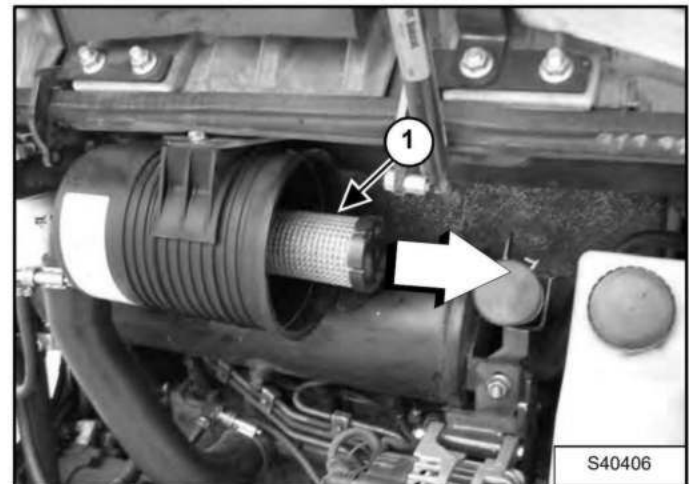

Remove the dust cover, outer filter and inner filter (Item 1) [Figure 145].

NOTE: Make sure all sealing surfaces are free of dirt and debris.

Install the new inner filter.

Install the outer filter and the dust cover.

Press the button on the condition indicator to remove the red ring.

FUEL SYSTEM

Fuel Specifications

Use only clean, high quality diesel fuel, Grade No. 2 or Grade No. 1.

The following is one suggested blending guideline which should prevent fuel gelling during cold temperatures:

TEMPERATURE	NO. 2	NO. 1
-9°C (+15°F)	100%	0%
Down to -29°C (-20°F)	50%	50%
Below -29°C (-20°F)	0%	100%

At a minimum, low sulfur diesel fuel must be used in this machine. Low sulfur is defined as 500 mg/kg (500 ppm) sulfur maximum.

The following fuels may also be used in this machine:

- Ultra low sulfur diesel fuel. Ultra low sulfur is defined as 15 mg/kg (15 ppm) sulfur maximum.
- Biodiesel blend fuel - Must contain no more than five percent biodiesel mixed with low sulfur or ultra low sulfur petroleum based diesel. This is commonly marketed as B5 blended diesel fuel. B5 blended diesel fuel must meet ASTM D975 (US Standard) or EN590 (EU Standard) specifications.

WARNING

AVOID INJURY OR DEATH

Stop and cool the engine before adding fuel. **NO SMOKING!** Failure to obey warnings can cause an explosion or fire.

W-2063-0807

WARNING

AVOID INJURY OR DEATH

Always clean up spilled fuel or oil. Keep heat, flames, sparks or lighted tobacco away from fuel and oil. Failure to use care around combustibles can cause explosion or fire.

W-2103-0508

Biodiesel Blend Fuel

Biodiesel blend fuel has unique qualities that should be considered before using in this machine:

- Cold weather conditions can lead to plugged fuel system components and hard starting.
- Biodiesel blend fuel is an excellent medium for microbial growth and contamination which can cause corrosion and plugging of fuel system components.
- Use of biodiesel blend fuel can result in premature failure of fuel system components, such as plugged fuel filters and deteriorated fuel lines.
- Shorter maintenance intervals can be required, such as cleaning the fuel system and replacing fuel filters and fuel lines.
- Using biodiesel blended fuels containing more than five percent biodiesel can affect engine life and cause deterioration of hoses, tubelines, injectors, injector pump and seals.

Apply the following guidelines if biodiesel blend fuel is used:

- Ensure the fuel tank is as full as possible at all times to prevent moisture from collecting in the fuel tank.
- Ensure that the fuel tank cap is securely tightened.
- Biodiesel blend fuel can damage painted surfaces, remove all spilled fuel from painted surfaces immediately.
- Drain all water from the fuel filter daily before operating the machine.
- Do not exceed engine oil change interval. Extended oil change intervals can cause engine damage.
- Before machine storage; drain the fuel tank, refill with 100% petroleum diesel fuel, add fuel stabilizer and run the engine for at least 30 minutes.

NOTE: Biodiesel blend fuel does not have long term stability and should not be stored for more than 3 months.

Dealer Copy -- Not for Resale

FUEL SYSTEM (CONT'D)

Filling The Fuel Tank

Figure 146

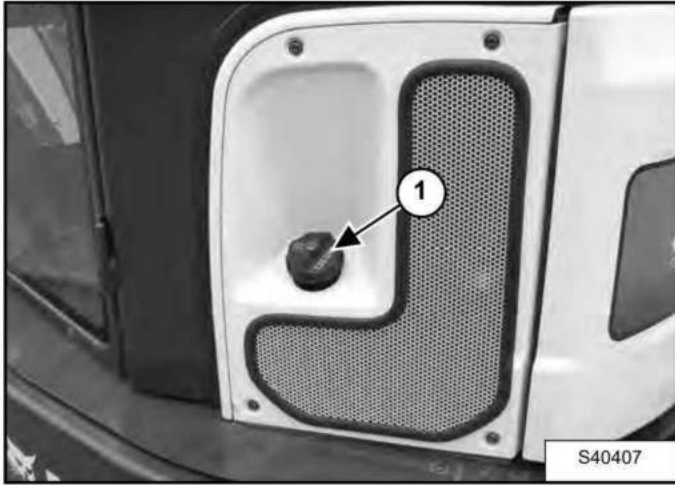

The fuel cap uses the start key to unlock the fuel cap.

Remove the fuel fill cap (Item 1) [Figure 146].

Use a clean, approved safety container to add fuel. Add fuel only in an area that has a free movement of air and no flames or sparks. **NO SMOKING!**

Install and tighten the fuel fill cap.

Clean up any spilled fuel.

See the service schedule for the service interval when to remove water from or replace the fuel filter. (See SERVICE SCHEDULE on Page 87.)

WARNING

AVOID INJURY OR DEATH

Stop and cool the engine before adding fuel. **NO SMOKING!** Failure to obey warnings can cause an explosion or fire.

W-2063-0807

WARNING

AVOID INJURY OR DEATH

Always clean up spilled fuel or oil. Keep heat, flames, sparks or lighted tobacco away from fuel and oil. Failure to use care around combustibles can cause explosion or fire.

W-2103-0508

FUEL SYSTEM (CONT'D)

Fuel Filter

Removing Water

Open the tailgate. (See TAILGATE on Page 92.)

Figure 147

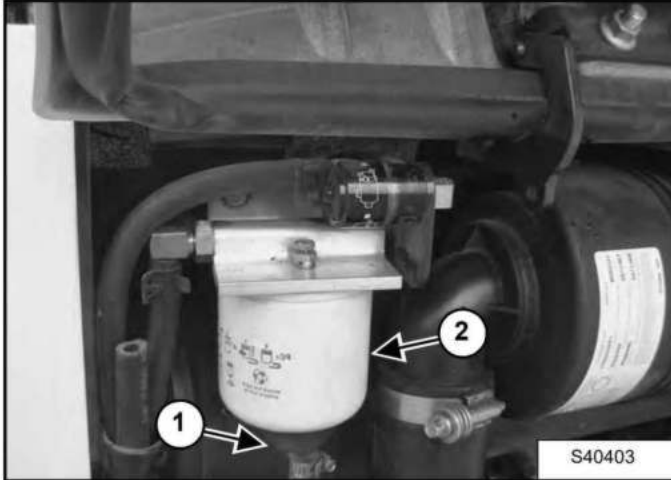

Loosen the drain (Item 1) [Figure 147] at the bottom of the filter to drain water from the filter into a container.

Clean up any spilled fuel.

Replacing Elements

Remove the filter (Item 2) [Figure 147].

Clean the area around the filter housing. Put clean oil on the seal of the new filter. Install the fuel filter and hand tighten.

Remove the air from the fuel system. (See Removing Air From The Fuel System on Page 100.)

Draining The Fuel Tank

See the service schedule for the correct service interval. (See SERVICE SCHEDULE on Page 87.)

Figure 148

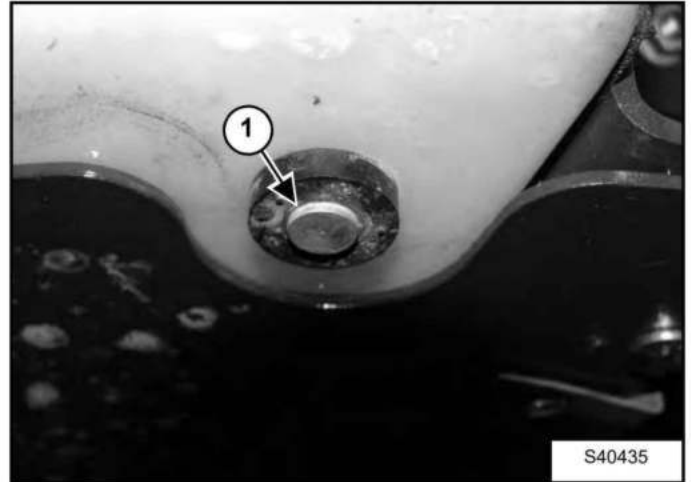

Remove the drain plug (Item 1) [Figure 148].

Drain the fuel into the container.

Reuse, recycle or dispose of fuel in an environmentally safe manner.

Reinstall the drain plug.

WARNING

AVOID INJURY OR DEATH

Diesel fuel or hydraulic fluid under pressure can penetrate skin or eyes, causing serious injury or death. Fluid leaks under pressure may not be visible. Use a piece of cardboard or wood to find leaks. Do not use your bare hand. Wear safety goggles. If fluid enters skin or eyes, get immediate medical attention from a physician familiar with this injury.

W-2072-0807

Dealer Copy -- Not for Resale

FUEL SYSTEM (CONT'D)

Removing Air From The Fuel System

After replacing the fuel filter or when the fuel tank has run out of fuel, air must be removed from the fuel system before starting the engine.

Open the tailgate. (See Opening And Closing on Page 92.)

Figure 149



Figure 150

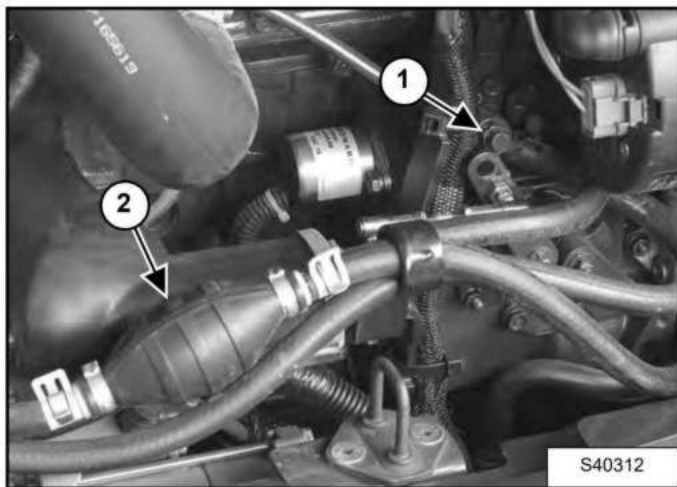

Open the fuel filter vent (Item 1) [Figure 149] and operate the hand pump (priming bulb) (Item 2) [Figure 150] until the fuel flows from the vent with no air bubbles.

Close the vent (Item 1) [Figure 149].

Start the engine. It can be necessary to open the vent (Item 1) [Figure 150] (at the fuel injection pump) briefly until the engine runs smoothly.

WARNING

AVOID INJURY OR DEATH

Diesel fuel or hydraulic fluid under pressure can penetrate skin or eyes, causing serious injury or death. Fluid leaks under pressure may not be visible. Use a piece of cardboard or wood to find leaks. Do not use your bare hand. Wear safety goggles. If fluid enters skin or eyes, get immediate medical attention from a physician familiar with this injury.

W-2072-0807

ENGINE LUBRICATION SYSTEM

Checking And Adding Engine Oil

Check the engine oil after every 8 - 10 hours of operation and before starting the engine. (See SERVICE SCHEDULE on Page 87.)

Figure 151

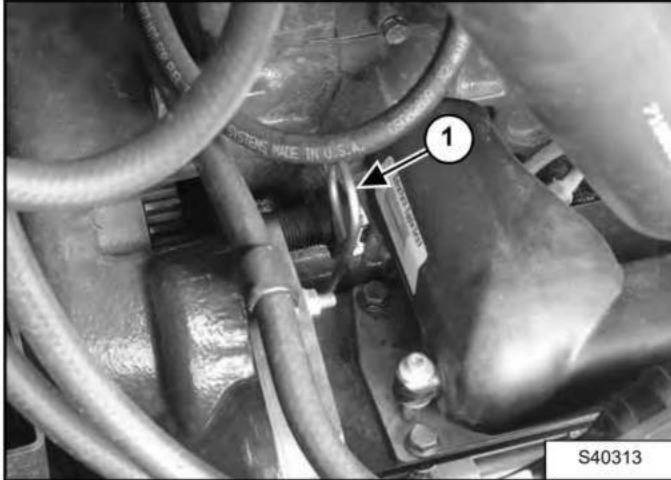

Open the tailgate and remove the dipstick (Item 1) [Figure 151].

Keep the oil level between the marks on the dipstick.

Use a good quality motor oil that meets the correct API Service Classification.

Engine Oil Chart

Figure 152

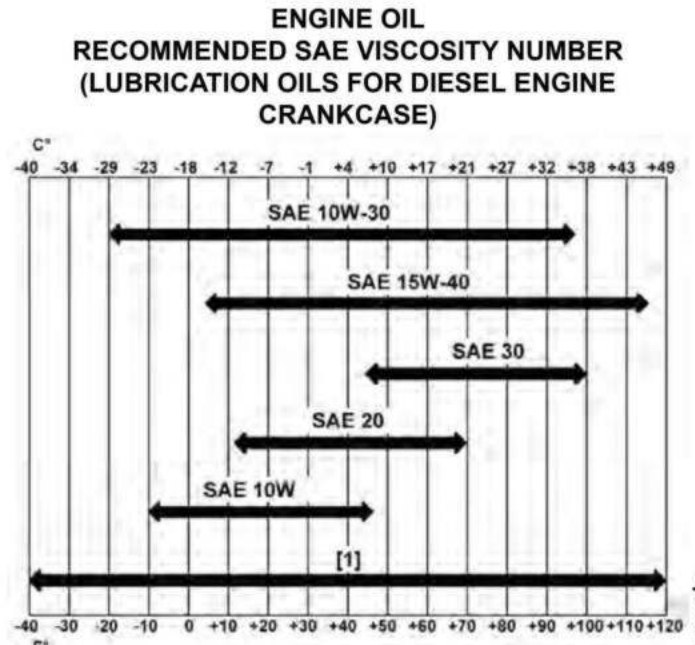

**TEMPERATURE RANGE ANTICIPATED BEFORE
NEXT OIL CHANGE (DIESEL ENGINES MUST USE API
CLASSIFICATION CI-4 OR BETTER)**

[1] Synthetic Oil - Use recommendation from Synthetic Oil Manufacturer.

Use good quality engine oil that meets API Service Classification of CI-4 or better [Figure 152].

Dealer Copy -- Not for Resale

! WARNING

AVOID INJURY OR DEATH

Always clean up spilled fuel or oil. Keep heat, flames, sparks or lighted tobacco away from fuel and oil. Failure to use care around combustibles can cause explosion or fire.

W-2103-0508

ENGINE LUBRICATION SYSTEM (CONT'D)

Removing And Replacing Oil And Filter

See the service schedule for the service interval for replacing the engine oil and filter. (See SERVICE SCHEDULE on Page 87.)

Rotate upperstructure so that the oil drain plug and the oil filter access cover is between the tracks.

Run the engine until it is at operating temperature. Stop the engine.

Open the tailgate. (See Opening And Closing on Page 92.)

Figure 153

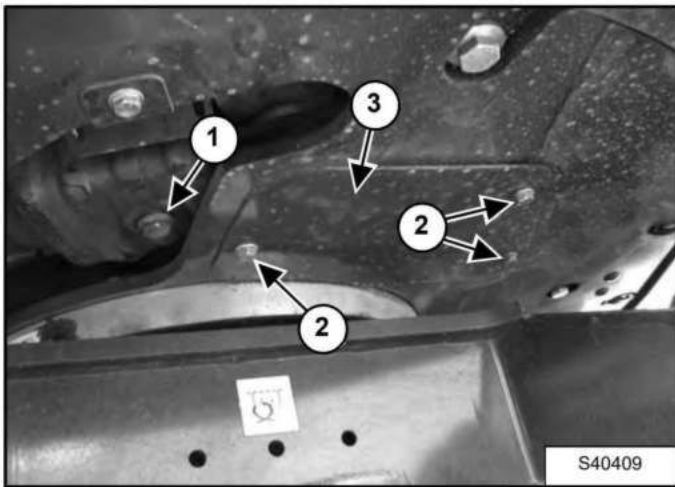

Place a container under the oil pan. Remove the drain plug (Item 1) [Figure 153] from the bottom of the engine oil pan.

Recycle or dispose of used oil in an environmentally safe manner.

Loosen the three bolts (Item 2) and then remove two of the bolts. Rotate the cover (Item 3) [Figure 153] to access the oil filter.

Figure 154

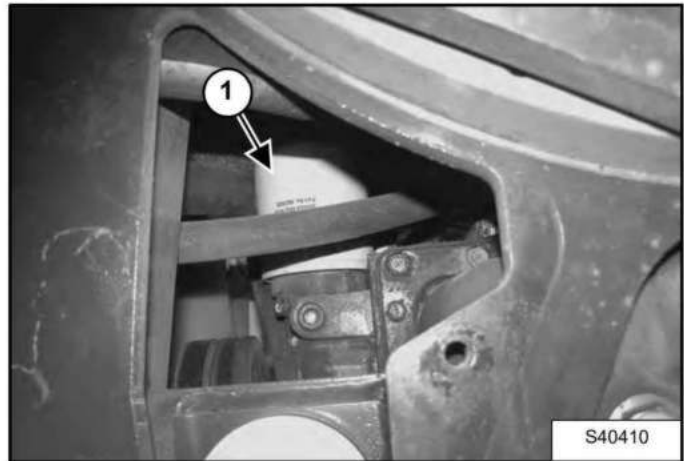

Remove the oil filter (Item 1) [Figure 154] and clean the filter housing surface.

Use a genuine Bobcat replacement filter. Put clean oil on the filter gasket. Install the filter and hand tighten.

Install and tighten the drain plug (Item 1) [Figure 153].

Reposition the cover, reinstall the two bolts, then tighten the three bolts (Item 2) [Figure 153].

Figure 155



Remove the fill cap (Item 1) [Figure 155].

Put oil in the engine. (See Checking And Adding Engine Oil on Page 101.)

Install the fill cap (Item 1) [Figure 155].

Start the engine and let it run for several minutes.

Stop the engine. Check for leaks at the oil filter. Check the oil level.

Add oil as needed if it is not at the top mark on the dipstick.

ENGINE COOLING SYSTEM

Check the cooling system every day to prevent overheating, loss of performance or engine damage. (See SERVICE SCHEDULE on Page 87.)

Cleaning

Open the right side cover. (See Opening And Closing on Page 93.)

NOTE: Allow the cooling system and engine to cool before servicing or cleaning the cooling system.

Figure 156

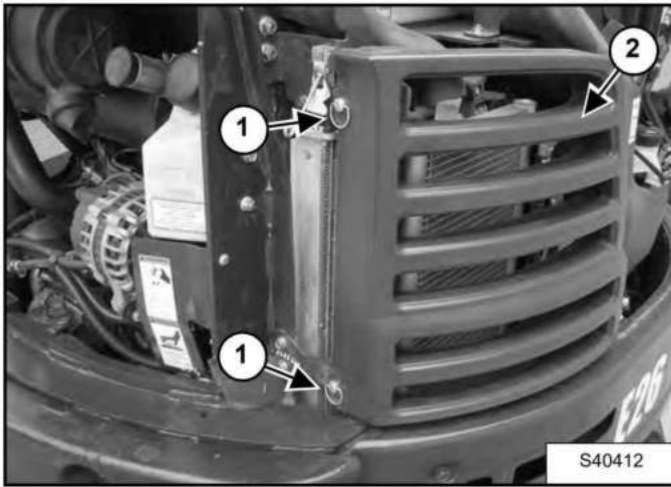

Turn the two quarter turn fasteners (Item 1) and remove the rear side cover (Item 2) [Figure 156].

Figure 157

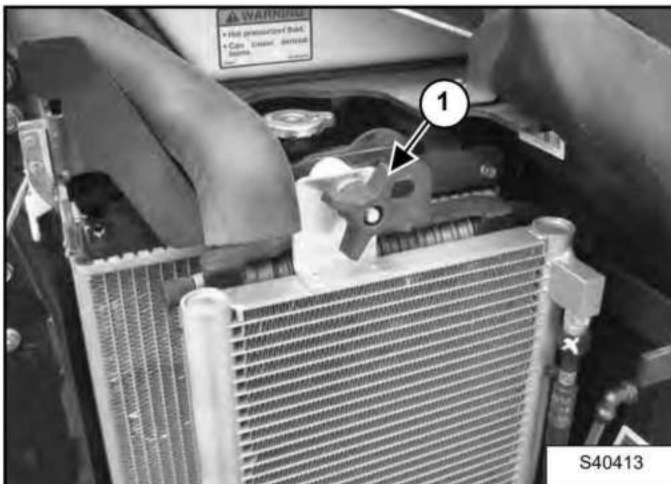

Loosen the knob (Item 1) [Figure 157]. Slide the knob toward the front of the machine.

Figure 158

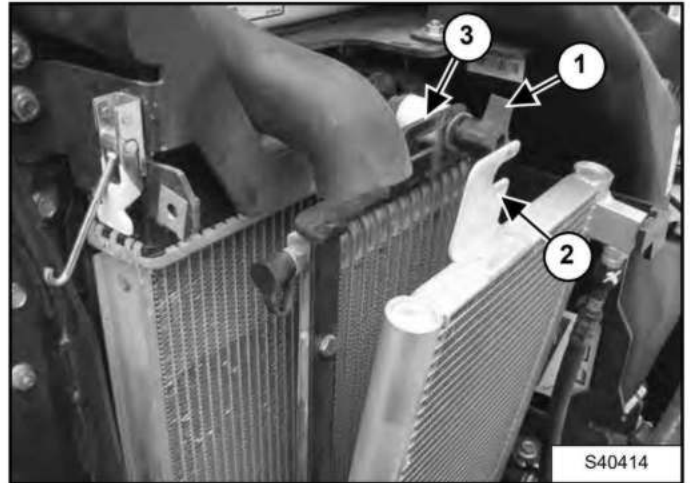

Slide the knob (Item 1) out of the condenser mount (Item 2) (if equipped) and the radiator mounting bracket (Item 3) [Figure 158]. Be careful not to damage fins.

Figure 159

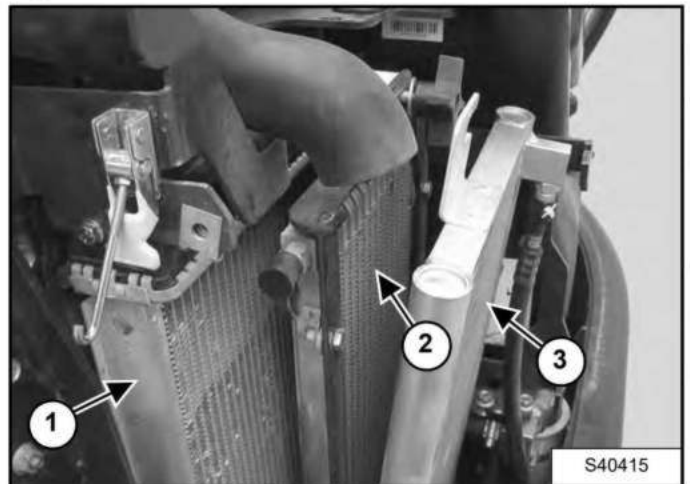

Use air pressure or water pressure to clean the radiator (Item 1), oil cooler (Item 2) and condenser (if equipped) (Item 3) [Figure 159]. Be careful not to damage fins when cleaning.

Position the knob (Item 1) so it fits into the radiator mount (Item 3) and the condenser mount (Item 2) [Figure 158] (if equipped).

Slide the knob (Item 1) toward the rear of the machine until it is fully seated in the slots of the mounting brackets. Tighten the knob (Item 1) [Figure 157]. Be careful not to damage fins.

Reinstall the rear side cover (Item 2) and turn the quarter turn fasteners (Item 1) [Figure 156] to secure the rear side cover.

Dealer Copy -- Not for Resale

ENGINE COOLING SYSTEM (CONT'D)

Checking Level

! WARNING

AVOID BURNS

Do not remove radiator cap when the engine is hot. You can be seriously burned.

W-2070-1203

! WARNING

AVOID INJURY OR DEATH

Wear safety glasses to prevent eye injury when any of the following conditions exist:

- When fluids are under pressure.
- Flying debris or loose material is present.
- Engine is running.
- Tools are being used.

W-2019-0907

IMPORTANT

AVOID ENGINE DAMAGE

Always use the correct ratio of water to antifreeze.

Too much antifreeze reduces cooling system efficiency and may cause serious premature engine damage.

Too little antifreeze reduces the additives which protect the internal engine components; reduces the boiling point and freeze protection of the system.

Always add a premixed solution. Adding full strength concentrated coolant can cause serious premature engine damage.

I-2124-0497

Open the tailgate. (See Opening And Closing on Page 92.)

Figure 160

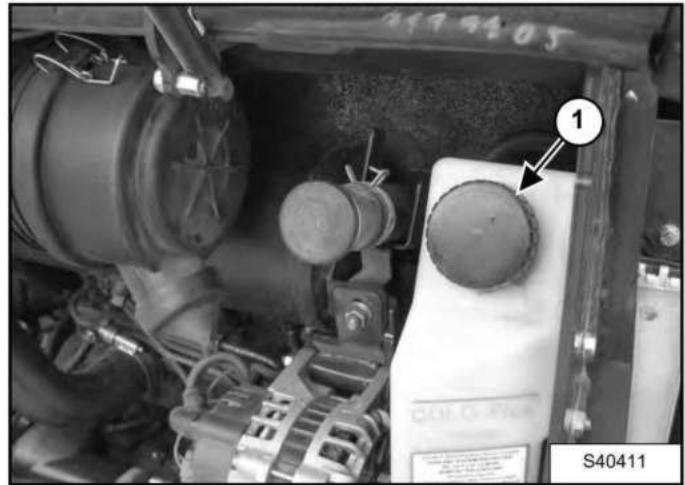

Check the coolant level in the coolant recovery tank (Item 1) [Figure 160].

The coolant level must be filled to the COLD FILL line marked on the on the coolant recovery tank.

NOTE: The cooling system is factory filled with propylene glycol (purple color). DO NOT mix propylene glycol with ethylene glycol.

ENGINE COOLING SYSTEM (CONT'D)

Removing And Replacing Coolant

See the service schedule for correct service intervals. (See SERVICE SCHEDULE on Page 87.)

Stop the engine. Open the tailgate. (See Opening And Closing on Page 92.)

! WARNING

AVOID BURNS

Do not remove radiator cap when the engine is hot. You can be seriously burned.

W-2070-1203

Figure 161

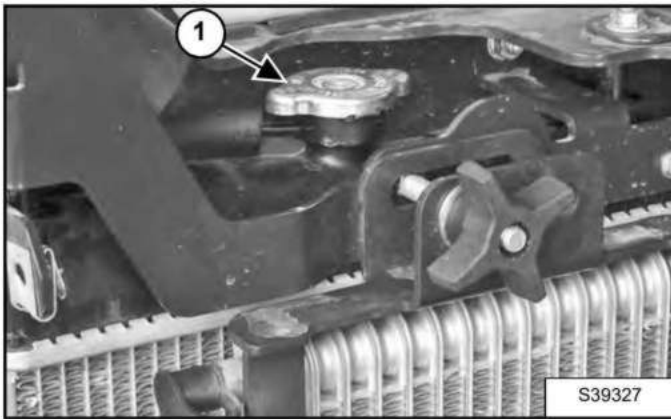

When the engine is cool, loosen and remove the coolant fill cap (Item 1) [Figure 161].

Figure 162



Install a hose on the drain valve at the bottom of the radiator. Open the drain valve (Item 1) [Figure 162] and drain the coolant into a container.

Figure 163

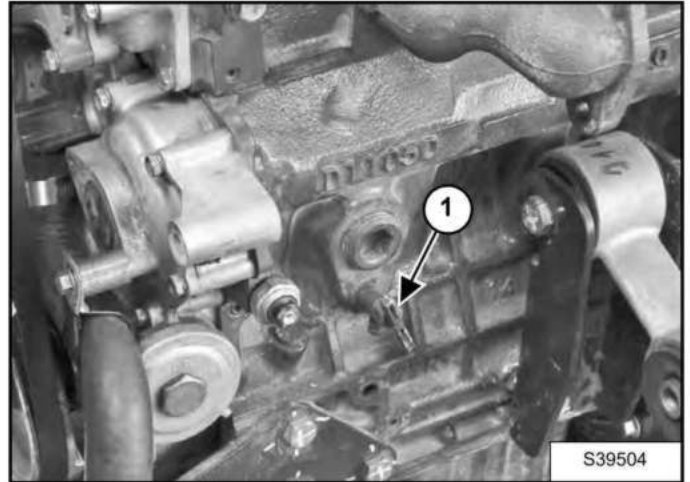

Install a hose on the drain valve located at the back of the engine block. Open the drain valve (Item 1) [Figure 163] and drain the coolant into a container.

NOTE: Engine is removed for photo clarity.

After all the coolant is removed, close both drain valves.

Recycle or dispose of the used coolant in an environmentally safe manner.

Mix the coolant in a separate container. (See Capacities on Page 175.)

NOTE: The cooling system is factory filled with propylene glycol (purple color). DO NOT mix propylene glycol with ethylene glycol.

The correct mixture of coolant to provide a -37°C (-34°F) freeze protection is 5 L (5.28 qt) propylene glycol mixed with 4,4 L (4.64 qt) of water **OR** 1 U.S. gal propylene glycol mixed with 3,3 L (3.5 qt) of water.

Add premixed coolant, 47% water and 53% propylene glycol to the coolant tank until the coolant level reaches the lower marker on the tank

Use a refractometer to check the condition of propylene glycol in your cooling system.

Add premixed coolant until the level is correct. Install the coolant fill cap.

Run the engine until it is at operating temperature. Stop the engine. Check the coolant level when cool. Add coolant as needed. Install the coolant fill cap.

Close the tailgate.

Dealer Copy -- Not for Resale

ELECTRICAL SYSTEM

Description

Figure 164

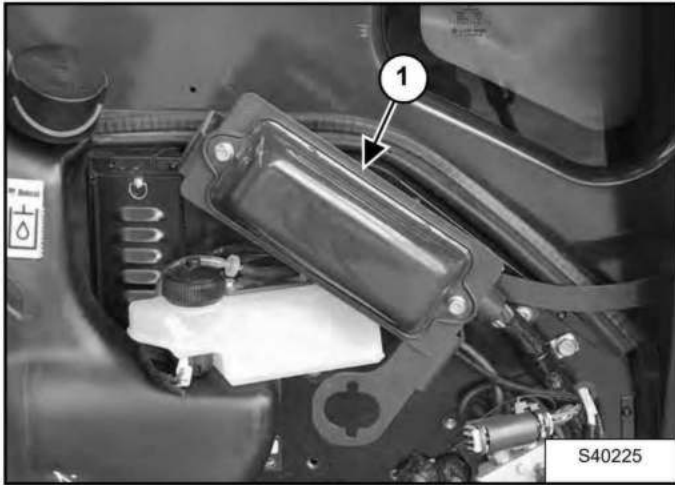

The excavator has a 12 volt, negative ground electrical system. The electrical system is protected by fuses located under the right side cover of the excavator (Item 1) [Figure 164]. The fuses will protect the electrical system when there is an electrical overload. The reason for the overload must be found and corrected before starting the engine again.

The battery cables must be clean and tight. Check the electrolyte level in the battery. Add distilled water as needed. Remove acid or corrosion from the battery and cables with a sodium bicarbonate and water solution.

Put Battery Saver P/N 6664458 or grease on the battery terminals and cable ends to prevent corrosion.

WARNING

AVOID INJURY OR DEATH

Batteries contain acid which burns eyes and skin on contact. Wear goggles, protective clothing and rubber gloves to keep acid off body.

In case of acid contact, wash immediately with water. In case of eye contact get prompt medical attention and wash eye with clean, cool water for at least 15 minutes.

If electrolyte is taken internally drink large quantities of water or milk! DO NOT induce vomiting. Get prompt medical attention.

W-2065-0807

Fuse And Relay Location / Identification

A decal is inside the fuse cover to show location and amp ratings.

Remove the cover to check or replace the fuses and relays.

The location and amperage ratings are shown in [Figure 165].

Always replace fuses using the same type and capacity.

ELECTRICAL SYSTEM (CONT'D)

Fuse And Relay Location / Identification (Cont'd)

Figure 165

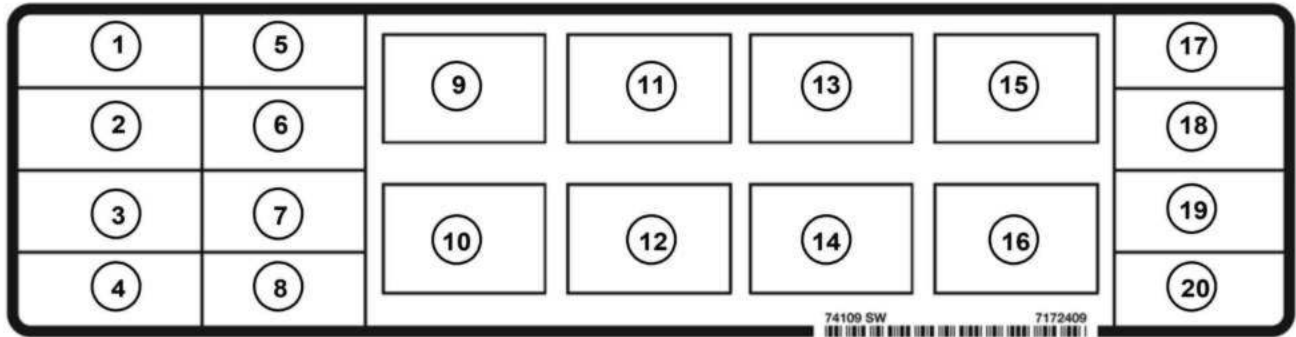

The location and amperage ratings are shown in the table below and on the decal [Figure 165]. Relays are identified by the letter “R” in the AMP column.

REF	ICON	DESCRIPTION	AMP	REF	ICON	DESCRIPTION	AMP	REF	ICON	DESCRIPTION	AMP
1		Auto Idle Controller (AIC)	20	9		Switched Power	R	17		Panel / Display Controller	25
2		Heater / HVAC	25	10		Fuel Shutoff	R	18		ACD Unswitched Power	25
3		Start Key	5	11		Heater / HVAC	R	19		LIGHTS	20
4		Fuel Shutoff	25	12		Lights	R	20		Power Port	15
5		Wiper / Washer	10	13		NOT USED	R				
6		Switched Power	20	14		Glow Plugs	R				
7		Alternator Excite / Heater	25	15		NOT USED	R				
8		ACD Switched Power	25	16		Starter	R				

Dealer Copy -- Not for Resale

ELECTRICAL SYSTEM (CONT'D)

Battery Maintenance

Open the right side cover. (See Opening And Closing on Page 93.)

Figure 166

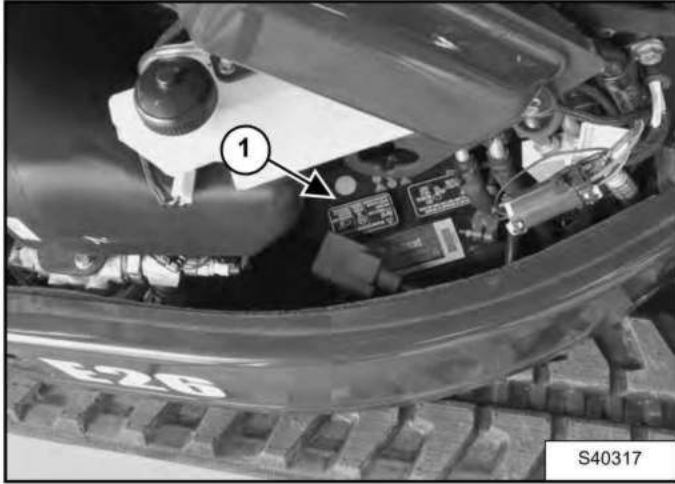

The battery (Item 1) [Figure 166] is located in the front of the right side upperstructure.

Figure 167

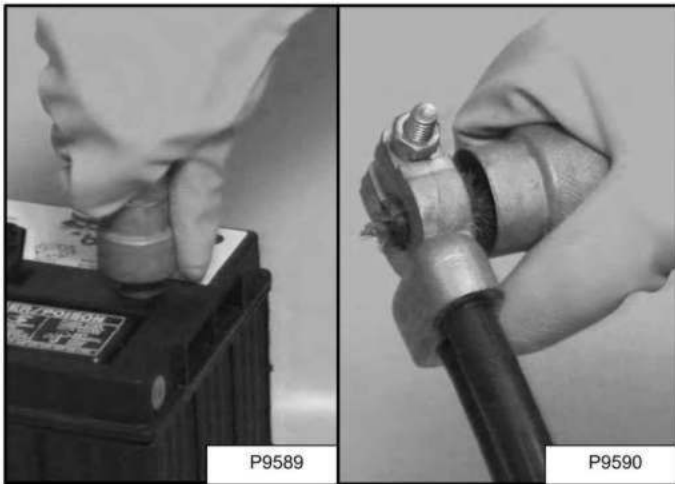

The battery cables must be clean and tight [Figure 167]. Remove acid or corrosion from the battery and cables using a sodium bicarbonate and water solution. Cover the battery terminals and cable ends with battery saver grease to prevent corrosion.

Check for broken or loose connections.

If the battery cables are to be removed for any reason, disconnect the negative (-) cable first. When installing the battery cables, make the last connection the negative (-) cable to the battery.

The original equipment battery is maintenance free. If a replacement battery is installed, check the electrolyte level in the battery.

If the electrolyte level is lower than 13 mm (0.50 in) above the plates, add distilled water only.

WARNING

AVOID INJURY OR DEATH

Batteries contain acid which burns eyes and skin on contact. Wear goggles, protective clothing and rubber gloves to keep acid off body.

In case of acid contact, wash immediately with water. In case of eye contact get prompt medical attention and wash eye with clean, cool water for at least 15 minutes.

If electrolyte is taken internally drink large quantities of water or milk! DO NOT induce vomiting. Get prompt medical attention.

W-2065-0807

Using A Booster Battery (Jump Starting)

IMPORTANT

If jump starting the excavator from a second machine:

When jump starting the excavator from a battery installed in a second machine, make sure the engine is NOT running while using the glow plugs. High voltage spikes from a running machine can burn out the glow plugs.

I-2060-0906

If it is necessary to use a booster battery to start the engine, BE CAREFUL! There must be one person in the operator's seat and one person to connect and disconnect the battery cables.

Be sure the key switch is OFF. The booster battery must be 12 volt.

Open the tailgate. (See Opening And Closing on Page 92.)

ELECTRICAL SYSTEM (CONT'D)

Using A Booster Battery (Jump Starting) (Cont'd)

Figure 168

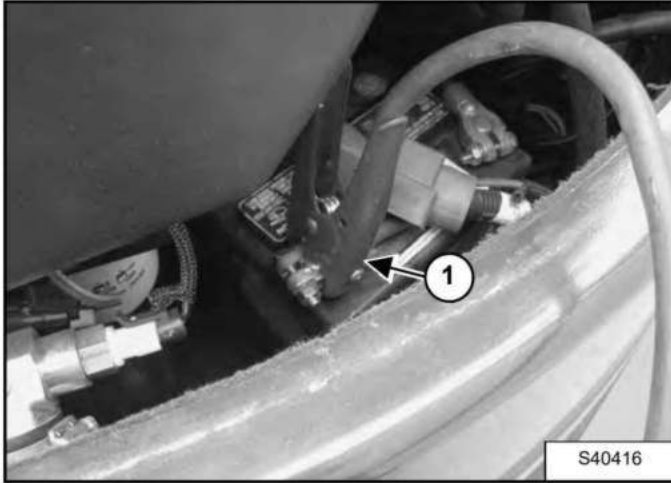

Connect one end of the first cable to the positive (+) terminal of the booster battery. Connect the other end of the same cable to the positive (+) terminal (Item 1) [Figure 168] of the excavator starter.

Figure 169

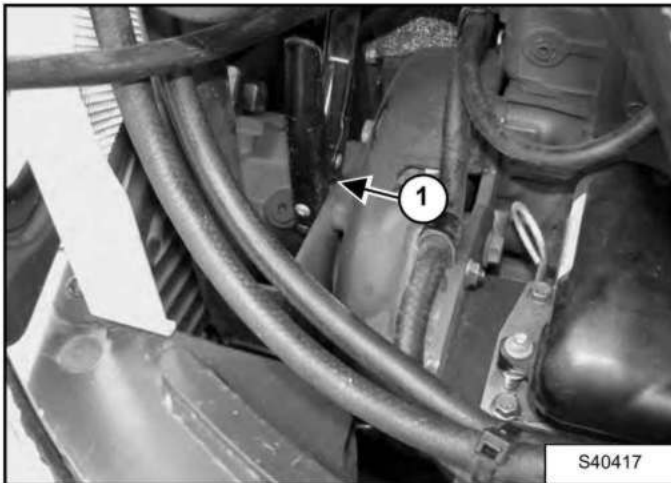

Connect one end of the second cable to the negative (-) terminal of the booster battery. Connect the other end of the same cable to a frame grounding point (Item 1) [Figure 169].

Start the engine. After the engine has started, remove the negative (-) cable first (Item 1) [Figure 169].

Disconnect the cable from the excavator starter (Item 1) [Figure 168].

NOTE: (See Cold Temperature Starting on Page 57.)

IMPORTANT

Damage to the alternator can occur if:

- Engine is operated with battery cables disconnected.
- Battery cables are connected when using a fast charger or when welding on the excavator. (Remove both cables from the battery.)
- Extra battery cables (booster cables) are connected wrong.

I-2223-0903

! WARNING

AVOID INJURY OR DEATH

Batteries contain acid which burns eyes and skin on contact. Wear goggles, protective clothing and rubber gloves to keep acid off body.

In case of acid contact, wash immediately with water. In case of eye contact get prompt medical attention and wash eye with clean, cool water for at least 15 minutes.

If electrolyte is taken internally drink large quantities of water or milk! DO NOT induce vomiting. Get prompt medical attention.

W-2065-0807

Dealer Copy - Not for Resale

ELECTRICAL SYSTEM (CONT'D)

Removing And Installing The Battery

Open the right side cover. (See Opening And Closing on Page 93.)

Remove the right side panel.

Figure 170

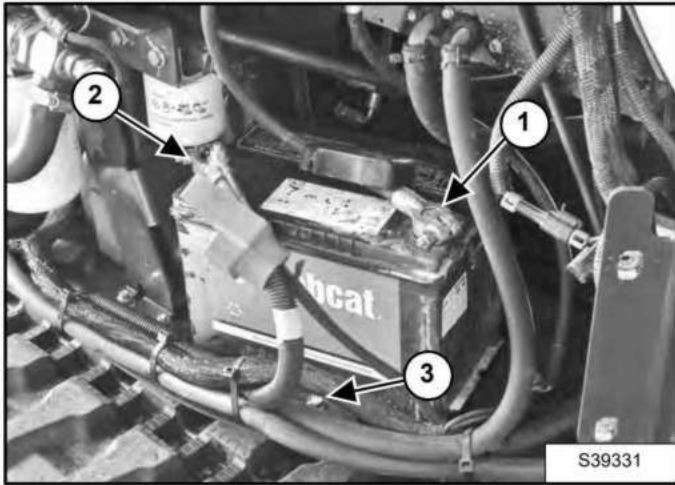

Disconnect the negative (-) cable (Item 1) **[Figure 170]** first.

Disconnect the positive (+) cable (Item 2) **[Figure 170]**.

Remove the bolt (Item 3) **[Figure 170]** and remove the hold-down clamp.

Remove the battery.

Always clean the terminals and the cable ends, even when installing a new battery.

Install the battery. Install the hold-down clamp and tighten the bolts.

Connect the battery cables. Connect the negative (-) cable (Item 1) **[Figure 170]** last to prevent sparks.

Tighten the terminal clamp nuts to 7 N•m (5 ft-lb) torque.

WARNING

AVOID INJURY OR DEATH

Batteries contain acid which burns eyes and skin on contact. Wear goggles, protective clothing and rubber gloves to keep acid off body.

In case of acid contact, wash immediately with water. In case of eye contact get prompt medical attention and wash eye with clean, cool water for at least 15 minutes.

If electrolyte is taken internally drink large quantities of water or milk! **DO NOT** induce vomiting. Get prompt medical attention.

W-2065-0807

HYDRAULIC SYSTEM

Checking And Adding Hydraulic Oil

Put the machine on a flat level surface.

Retract the arm and bucket cylinders, put the bucket on the ground and lower the blade. Stop the engine.

Open the right side cover. (See Opening And Closing on Page 93.)

Figure 171

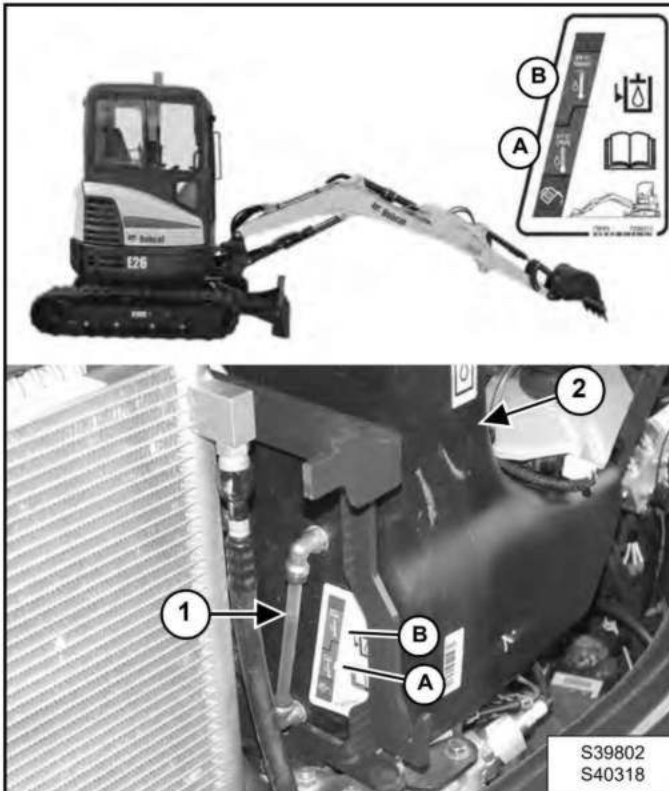

Park the machine in the position shown [Figure 171]. (The preferred method is to check the hydraulic oil when it is cold.)

Check the hydraulic oil level, it must be visible in the sight gauge (Item 1) [Figure 171]. The decal on the hydraulic tank shows the correct fill level.

- A - Correct Oil Level COLD (Preferred)
- B - Correct Oil Level HOT (Optional)

Clean the surface around the reservoir cap and remove the cap from the reservoir (Item 2) [Figure 171].



AVOID INJURY OR DEATH

Always clean up spilled fuel or oil. Keep heat, flames, sparks or lighted tobacco away from fuel and oil. Failure to use care around combustibles can cause explosion or fire.

W-2103-0508

Figure 172



Check the condition of the fill strainer screen (Item 1) [Figure 172]. Clean or replace as necessary.

Be sure the screen is installed before adding fluid.

Add the correct fluid to the reservoir until it is visible in the sight gauge.

Check the cap and clean as necessary. Replace the cap if damaged.

Install the cap.

Close the right side cover and tailgate.

Dealer Copy -- Not for Resale

HYDRAULIC SYSTEM (CONT'D)

Hydraulic / Hydrostatic Fluid Chart

Figure 173

HYDRAULIC / HYDROSTATIC FLUID RECOMMENDED ISO VISCOSITY GRADE (VG) AND VISCOSITY INDEX (VI)

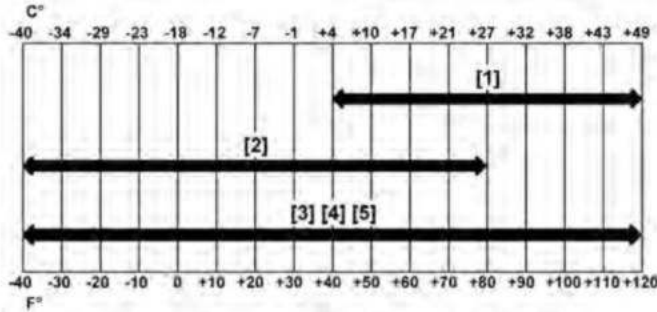

TEMPERATURE RANGE ANTICIPATED DURING MACHINE USE

- [1] VG 100; Minimum VI 130
- [2] VG 46; Minimum VI 150
- [3] BOBCAT All-Season Fluid
- [4] BOBCAT Synthetic Fluid
- [5] BOBCAT Biodegradable Hydraulic / Hydrostatic Fluid (Unlike biodegradable fluids that are vegetable based, Bobcat biodegradable fluid is formulated to prevent oxidation and thermal breakdown at operating temperatures.)

Install the oil fill cap.

Removing And Replacing The Hydraulic Filters

WARNING

AVOID INJURY OR DEATH

Always clean up spilled fuel or oil. Keep heat, flames, sparks or lighted tobacco away from fuel and oil. Failure to use care around combustibles can cause explosion or fire.

W-2103-0508

Hydraulic Filter

See the service schedule for the correct service interval. (See SERVICE SCHEDULE on Page 87.)

Figure 174



For easier access to change the hydraulic filter, remove the lower right side panel.

Remove the four bolts (Item 1) and the side panel (Item 2) [Figure 174]. Remove the side panel.

Open the right side cover. (See Opening And Closing on Page 93.)

Dealer Copy -- Not for Resale

HYDRAULIC SYSTEM (CONT'D)

Removing And Replacing The Hydraulic Filters (Cont'd)

Figure 175

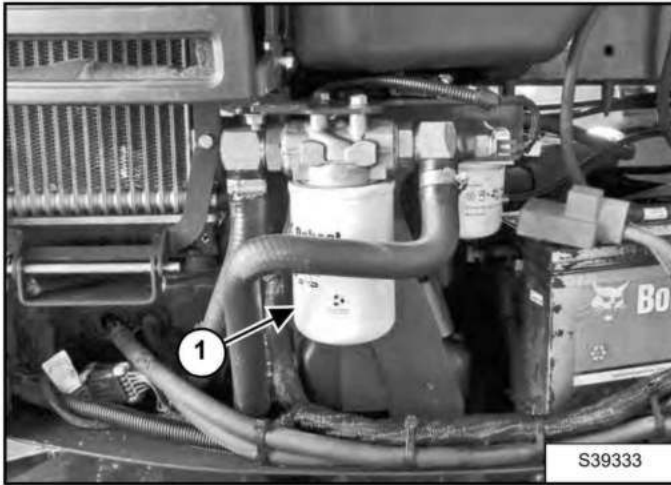

Remove the hydraulic filter (Item 1) [Figure 175].

Clean the housing where the filter gasket makes contact.

Put clean hydraulic oil on the gasket. Install the new filter and hand tighten only. Use a genuine Bobcat replacement filter.

WARNING

AVOID INJURY OR DEATH

Always clean up spilled fuel or oil. Keep heat, flames, sparks or lighted tobacco away from fuel and oil. Failure to use care around combustibles can cause explosion or fire.

W-2103-0508

Case Drain Filter

See the service schedule for the correct service interval. (See SERVICE SCHEDULE on Page 87.)

For easier access to change the hydraulic filter, remove the lower right side panel.

Figure 176



Remove the four bolts (Item 1) and the side panel (Item 2) [Figure 176]. Remove the side panel.

Open the right side cover. (See Opening And Closing on Page 93.)

Figure 177

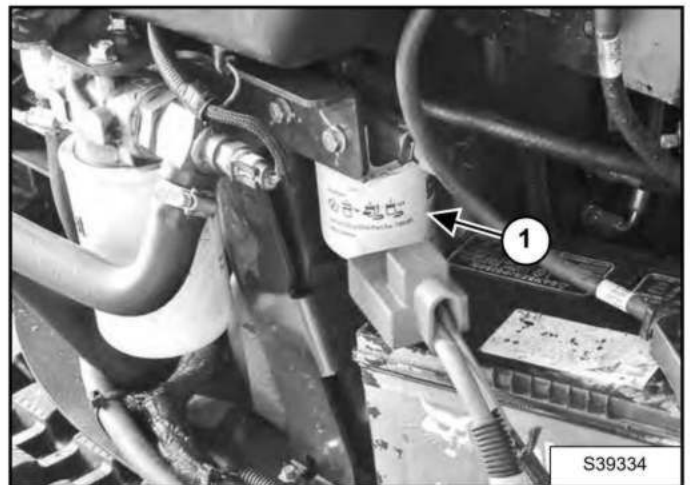

Remove the case drain filter (Item 1) [Figure 177].

Clean the housing where the filter gasket makes contact.

Put clean hydraulic oil on the gasket. Install the new filter and hand tighten only.

Dealer Copy -- Not for Resale

HYDRAULIC SYSTEM (CONT'D)

Removing And Replacing The Hydraulic Oil

See the service schedule for the correct service interval. (See SERVICE SCHEDULE on Page 87.)

WARNING

AVOID INJURY OR DEATH

Diesel fuel or hydraulic fluid under pressure can penetrate skin or eyes, causing serious injury or death. Fluid leaks under pressure may not be visible. Use a piece of cardboard or wood to find leaks. Do not use your bare hand. Wear safety goggles. If fluid enters skin or eyes, get immediate medical attention from a physician familiar with this injury.

W-2072-0807

Retract the arm and bucket cylinders, lower the bucket to the ground. Stop the engine.

Open the tailgate. (See Opening And Closing on Page 92.)

Figure 178



The hydraulic oil drain plug (Item 1) [Figure 178] is located below right side of the upperstructure.

Remove the plug (Item 1) [Figure 178].

Drain the fluid into a container.

Recycle or dispose of the fluid in an environmentally safe manner.

Install the plug (Item 1) [Figure 178].

Add fluid to the reservoir. (See Checking And Adding Hydraulic Oil on Page 111.)

Figure 179

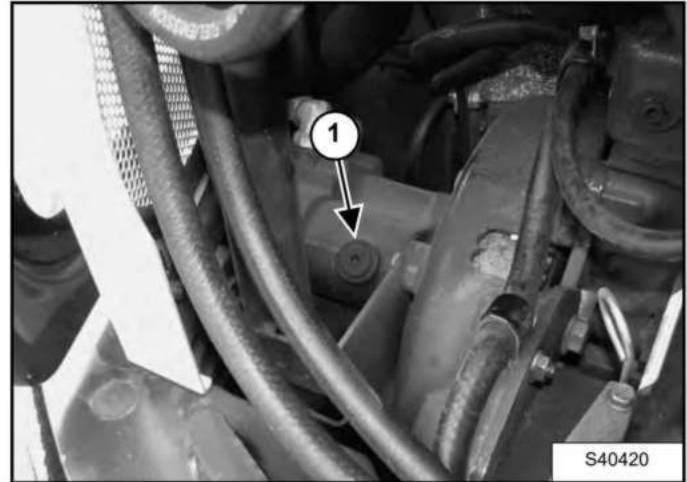

With the engine OFF, loosen the plug (Item 1) [Figure 179] on the hydraulic pump. Tighten the plug after a steady stream of hydraulic oil, free of any air bubbles, drains from the plug. **DO NOT RUN THE MACHINE WITH THE PLUG OPEN.**

Figure 180

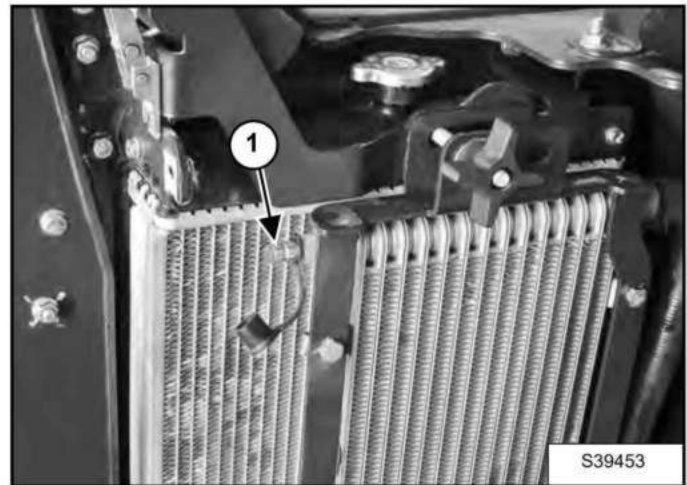

There is also a port (Item 1) [Figure 180] on the hydraulic cooler for bleeding air. Install a diagnostic coupler and hose on this fitting to allow air to be bled from the hydraulic system after the hydraulic oil has been replaced.

Start the engine and operate the machine through the hydraulic functions. Stop the engine. Check the fluid level and add as needed.

SPARK ARRESTOR MUFFLER

Cleaning Procedure

See the SERVICE SCHEDULE for the correct service interval. (See SERVICE SCHEDULE on Page 87.)

WARNING

AVOID INJURY OR DEATH

When an engine is running in an enclosed area, fresh air must be added to avoid concentration of exhaust fumes. If the engine is stationary, vent the exhaust outside. Exhaust fumes contain odorless, invisible gases which can kill without warning.

W-2050-0807

WARNING

Stop engine and allow the muffler to cool before cleaning the spark chamber. Wear safety goggles. Failure to obey can cause serious injury.

W-2011-1285

WARNING

Never use machine in atmosphere with explosive dust or gases or where exhaust can contact flammable material. Failure to obey warnings can cause injury or death.

W-2068-1285

WARNING

When the engine is running during service, the steering levers must be in neutral.

Failure to do so can cause injury or death.

W-2203-0595

IMPORTANT

This machine is factory equipped with a U.S.D.A. Forestry Service approved spark arrester exhaust system.

The spark arrester muffler, if equipped, must be cleaned to keep it in working condition. The spark arrester muffler must be serviced by dumping the spark chamber every 100 hours of operation.

On some models, the turbocharger functions as the spark arrester and must operate correctly for proper spark arrester function.

If this machine is operated on flammable forest, brush, or grass covered land, it must be equipped with a spark arrester attached to the exhaust system and maintained in working order. Failure to do so will be in violation of California State Law, Section 4442. PRC. Refer to local laws and regulations for spark arrester requirements.

I-2284-0111

Do not operate the excavator with a defective exhaust system.

Stop the engine. Open the tailgate. (See TAILGATE on Page 92.)

Dealer Copy -- Not for Resale

SPARK ARRESTOR MUFFLER

Cleaning Procedure (Cont'd)

Figure 181

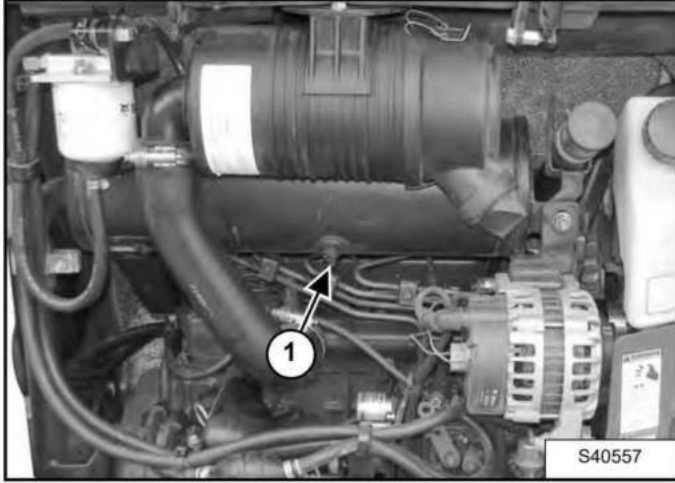

Remove the plug (Item 1) [Figure 181] from the bottom of the muffler.

Start the engine and run for about 10 seconds while a second person, wearing safety glasses, holds a piece of wood over the outlet of the muffler. The carbon deposits will be forced out of the muffler plug hole (Item 1) [Figure 181].

Stop the engine. Install and tighten the plug.

Close the tailgate.

TRACK TENSION

Checking Tension

NOTE: The wear of the pins and bushings on the undercarriage vary with the working conditions and the different types of soil conditions. It is necessary to inspect track tension and maintain the correct tension. See service schedule for the correct service interval. (See **SERVICE SCHEDULE** on Page 87.)

Raise the side of the machine (approximately 102 mm [4 in]) using the boom and arm.

Figure 182

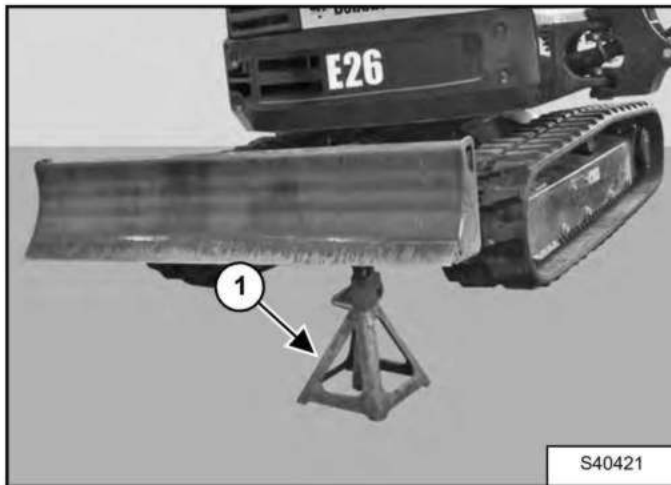
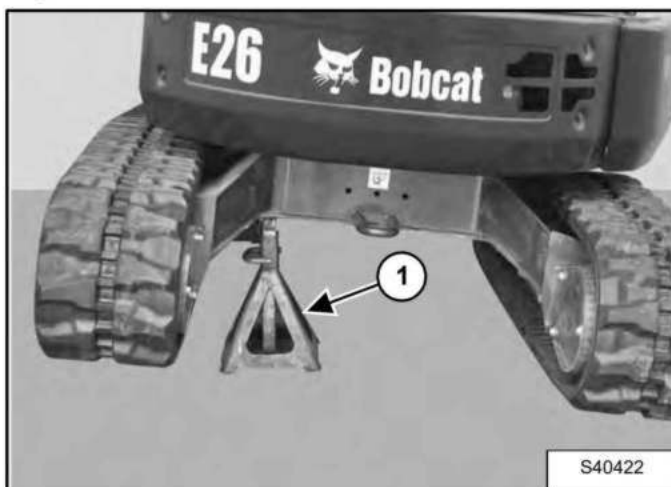

Figure 183



Raise the blade fully and install jackstands under the blade and track frame (Item 1) [Figure 182] and [Figure 183]. Raise the boom until all machine weight is on the jackstands.

Stop the engine.



AVOID INJURY

Keep fingers and hands out of pinch points when checking the track tension.

W-2142-0903

Rubber Track Clearance

Figure 184

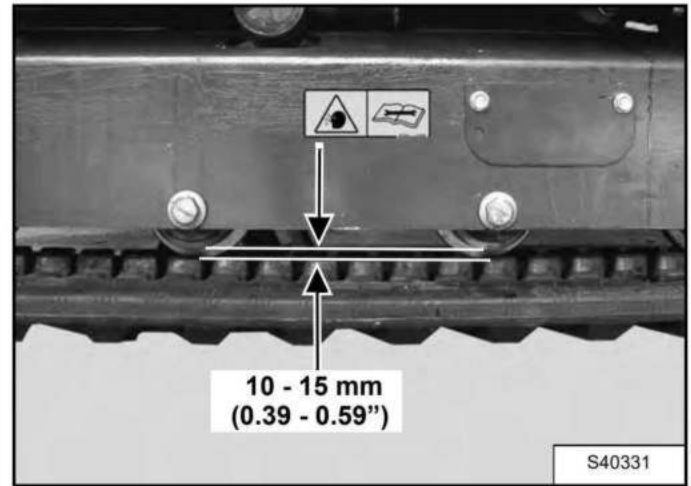
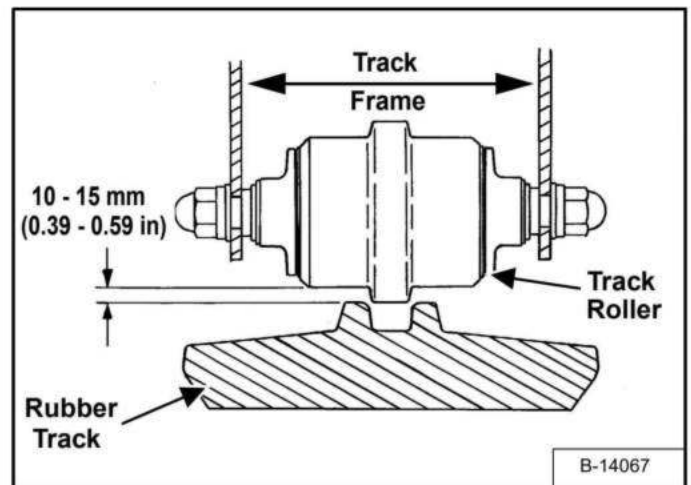

Figure 185



Measure the clearance at either middle track roller. Do not get fingers into pinch points between the track and the track roller. Use a bolt or a dowel of the appropriate size to check the gap between the contact edge of the roller and the top edge of the track guide [Figure 184] and [Figure 185].

Track Clearance	10 - 15 mm (0.39 - 0.59 in)
-----------------	--------------------------------

Dealer Copy -- Not for Resale

TRACK TENSION (CONT'D)

Adjusting Tension

Figure 186



Loosen the access cover bolts and pivot the access cover open [Figure 186].

Increase Track Tension

Add grease to the fitting (Item 1) [Figure 186] until the track tension is correct.

Decrease Track Tension

WARNING

AVOID INJURY OR DEATH

If grease fitting is removed before pressure is released, the fitting can come off with great force and cause serious injury or death.

W-2490-0104

Pressure must be released from the grease cylinder to decrease track tension.

Loosen the bleed fitting (NOT the grease fitting) (Item 2) [Figure 186] and release pressure until the track tension is correct.

NOTE: DO NOT loosen the bleed fitting (Item 2) [Figure 186] for more than eight turns.

Tighten the bleed fitting to 80 - 100 N•m (59 - 74 ft-lb) torque.

Pivot the access cover closed and tighten the access cover bolts.

Raise the machine and remove the jackstands.

Repeat the procedure for the other side.

Dispose of grease in an environmentally safe manner.

TRAVEL MOTOR

Checking And Adding Oil

Figure 187

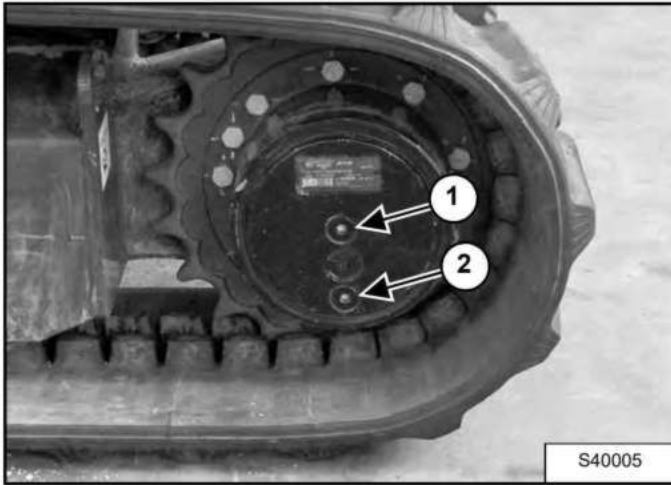

Park the excavator on a level surface with the plugs (Items 1 and 2) [Figure 187] in the vertical position as shown.

Remove the plug (Item 1) [Figure 187]. The lube level must be at the bottom edge of the hole.

Add lubricant (SAE 90W) through the hole if the lube level is low.

Removing And Replacing Oil

See the service schedule for the correct service interval. (See SERVICE SCHEDULE on Page 87.)

Park the excavator on a level surface with plugs (Items 1 and 2) [Figure 187] in the vertical position shown. Remove both plugs and drain the lubricant into a container.

WARNING

AVOID INJURY OR DEATH

Always clean up spilled fuel or oil. Keep heat, flames, sparks or lighted tobacco away from fuel and oil. Failure to use care around combustibles can cause explosion or fire.

W-2103-0508

Install the bottom plug (Item 2) [Figure 187]. Add lubricant through the center plug hole until the lube level is at the bottom edge of the hole.

Install the plug (Item 1) [Figure 187].

Dealer Copy -- Not for Resale

ALTERNATOR AND FAN BELT

Belt Adjustment

Stop the engine and open the tailgate. (See Opening And Closing on Page 92.)

Figure 188

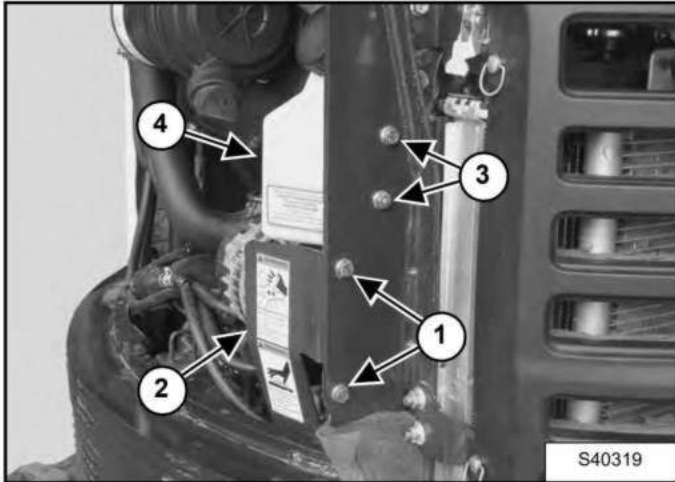

Remove belt shield mounting nuts and bolts (Item 1) and remove the belt shield (Item 2) [Figure 188].

Remove the two bolts (Item 3) and the coolant recovery tank (Item 4) [Figure 188].

Figure 189

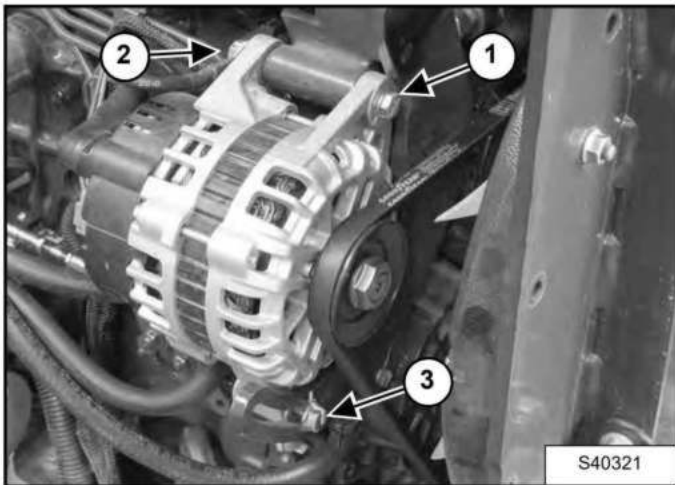

Loosen the bolt (Item 1) and nut (Item 2) and the bolt (Item 3) [Figure 189] until the alternator can be moved toward the engine.

If a belt tension tool is available, move the alternator until the belt has (new belt = 272 - 292 N [61 - 65 lbf] or used belt = 233 - 252 N [53 - 57 lbf] tension.

If a belt tension tool is not available, move the alternator until the belt has 8,0 mm (5/16 in) movement at the middle of the belt span with 66 N (15 lbf) of force

Tighten the mounting and adjustment bolts.

Install the coolant recovery tank (Item 4) with the two bolts (Item 3) [Figure 188].

Install the belt shield (Item 2) with belt shield mounting nuts and bolts (Item 1) [Figure 188].

Close the tailgate.

Belt Replacement

Remove belt shield mounting nuts and bolts (Item 1) and remove the belt shield (Item 2) [Figure 188].

Remove the two bolts (Item 3) and the coolant recovery tank (Item 4) [Figure 188].

Loosen the bolt (Item 1) and nut (Item 2) and the bolt (Item 3) [Figure 189] until the alternator can be moved toward the engine.

Remove the old belt and install a new belt.

Install the coolant recovery tank (Item 4) with the two bolts (Item 3) [Figure 188].

Install the belt shield (Item 2) with belt shield mounting nuts and bolts (Item 1) [Figure 188].

Close the tailgate.

AIR CONDITIONING COMPRESSOR BELT

Belt Adjustment

Figure 190

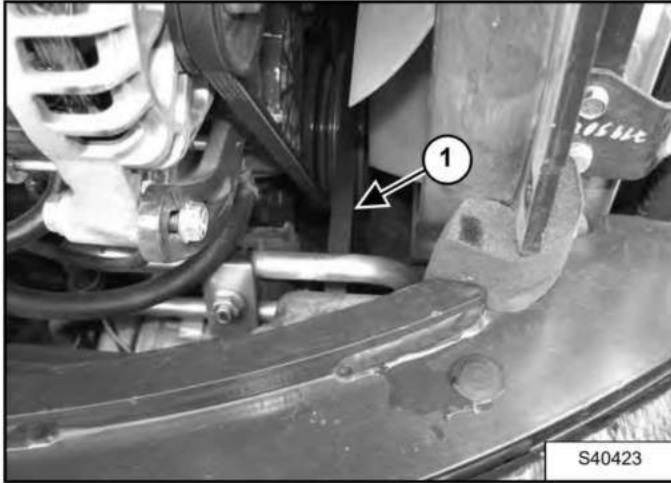

The air conditioning compressor belt (Item 1) [Figure 190] is a special maintenance free type that is pretensioned over the pulleys. This belt eliminates the need for a tensioning device and does not require periodic adjustment. Contact your Bobcat dealer for replacement parts.

Belt Replacement

The counterweight must be removed to service the air conditioning compressor belt. See your Bobcat dealer for service.

X-CHANGE™

Inspection And Maintenance

Figure 191

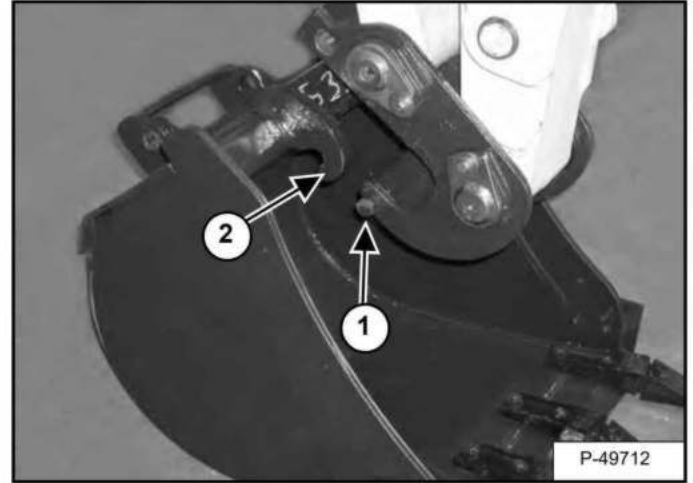

Inspect the X-Change (if equipped) for wear or damage. Inspect the X-Change pins (Item 1) and hooks (Item 2) [Figure 191] (on the attachment) for wear or damage.

Repair or replace damaged parts.

Dealer Copy -- Not for Resale

TRACK ROLLER AND IDLER LUBRICATION

Procedure

The track rollers and idlers require no maintenance. The bearings are a sealed design.

BUCKET

Bucket Teeth Removal And Installation

! WARNING

Wear safety glasses to prevent eye injury when any of the following conditions exist:

- Pressurized fluids and springs or other stored energy components.
- Flying debris or loose material is present.
- Engine is running.
- Tools are being used.

W-2505-0604

Position the bucket so the bucket teeth are at a 30° angle up from the ground for accessibility to the teeth.

Lower the boom until the bucket is fully on the ground.

Stop the engine and exit the excavator.

Figure 192

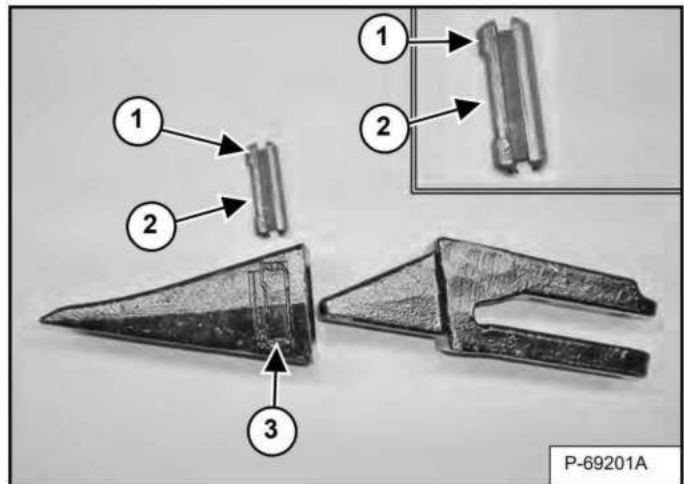

The retaining pin (Item 1) must be installed as shown (notch [Item 2] to the front) for proper fit and tooth retention. The side of the tooth point (Item 3) [Figure 192] also shows the correct orientation of the retaining pin.

Installation: Position the new tooth point on the shank and install a new retaining pin. Install the retaining pin until it is flush with the top of the point.

Dealer Copy -- Not for Resale

LUBRICATION OF THE HYDRAULIC EXCAVATOR

Lubrication Locations

Lubricate the excavator as specified in the service schedule for the best performance of the machine. (See SERVICE SCHEDULE on Page 87.)

Always use a good quality lithium based multipurpose grease when lubricating the machine. Apply the lubricant until extra grease shows.

Lubricate the following locations on the excavator EVERY 8 - 10 HOURS:

Figure 193

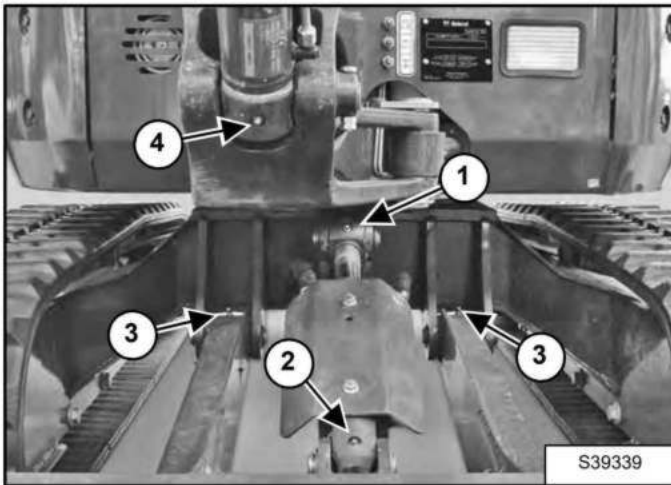

Ref Description (# of Fittings)

1. Blade Cylinder Rod End (1) [Figure 193].
2. Blade Cylinder Base End (1) [Figure 193].
3. Blade Pivots (2) [Figure 193].
4. Boom Cylinder Base End (1) [Figure 193].

Figure 194

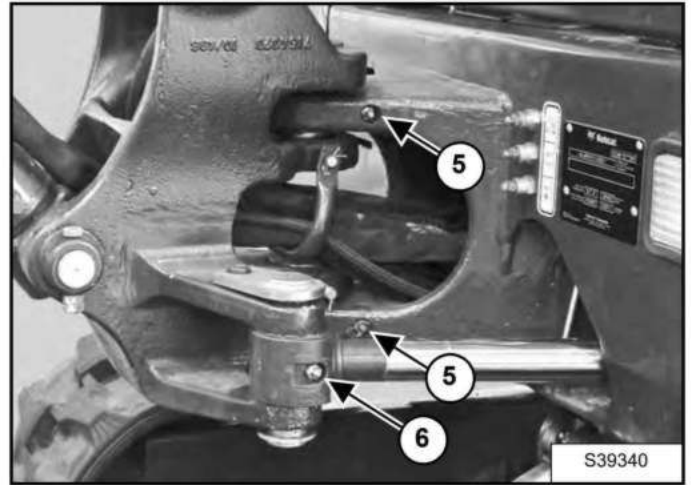

5. Boom Swing Pivot (3) [Figure 194].
6. Boom Swing Cylinder Rod End (1) [Figure 194].

Figure 195

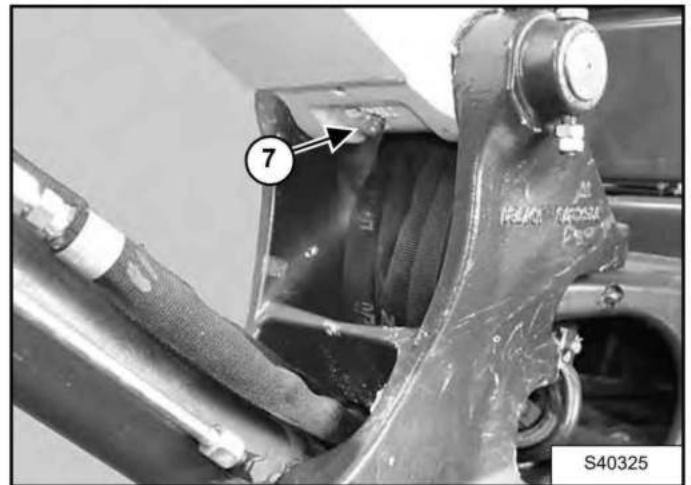

7. Boom Pivot (1) [Figure 195].

Dealer Copy -- Not for Resale

LUBRICATION OF THE HYDRAULIC EXCAVATOR (CONT'D)

Lubrication Locations (Cont'd)

Figure 196



8. Boom Cylinder Rod End (1) [Figure 196].

Figure 197

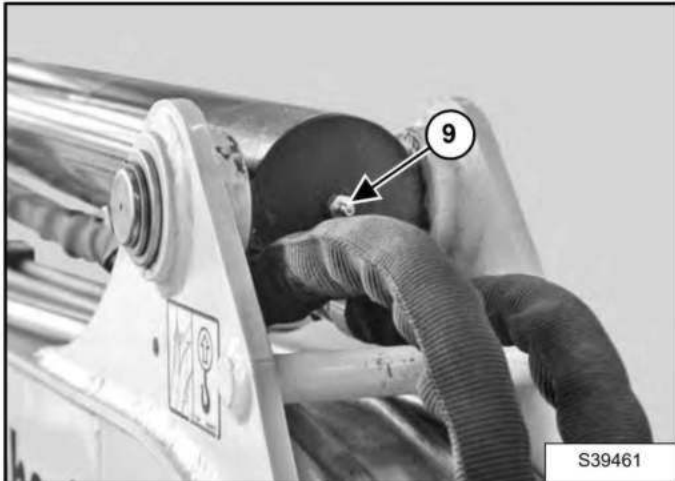

9. Arm Cylinder Base End (1) [Figure 197].

Figure 198

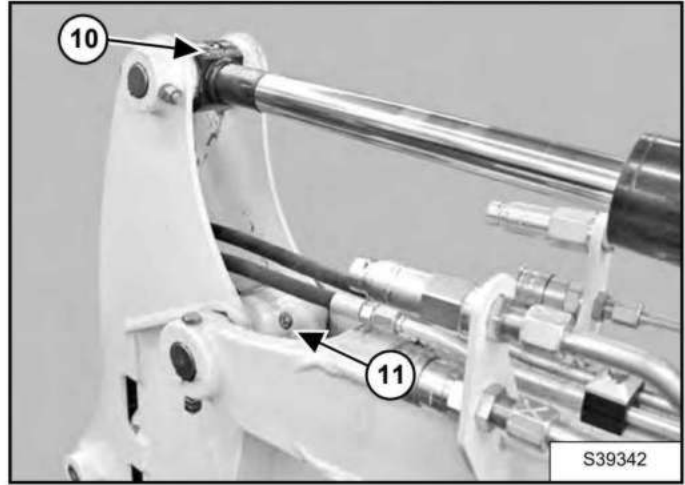

10. Arm Cylinder Rod End (1) [Figure 198].

11. Arm Pivot (1) [Figure 198].

Figure 199

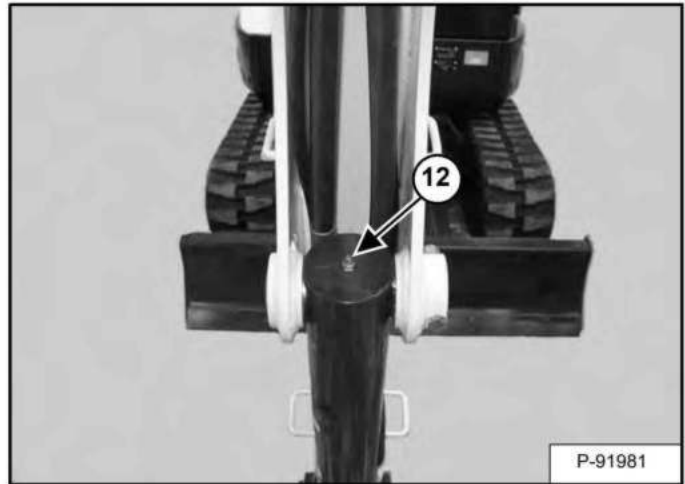

12. Bucket Cylinder Base End (1) [Figure 199].

Dealer Copy -- Not for Resale

LUBRICATION OF THE HYDRAULIC EXCAVATOR (CONT'D)

Lubrication Locations (Cont'd)

Figure 200

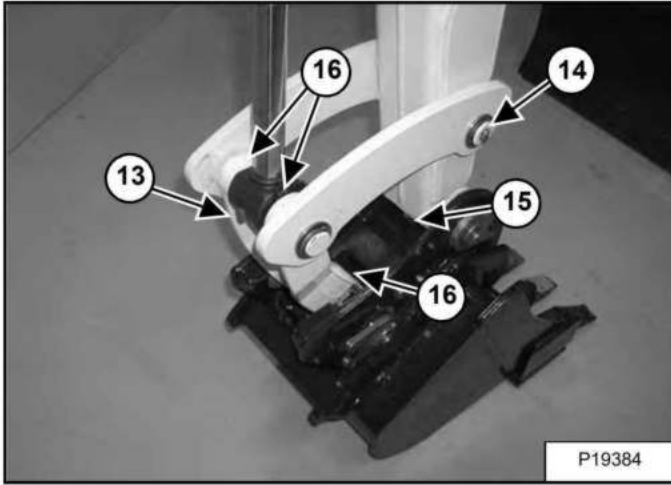

- 13. Bucket Cylinder Rod End (1) [Figure 200].
- 14. Bucket Link Pin (1) [Figure 200].
- 15. Bucket Pivot (1) [Figure 200].
- 16. Bucket Link (3) [Figure 200].

Figure 201

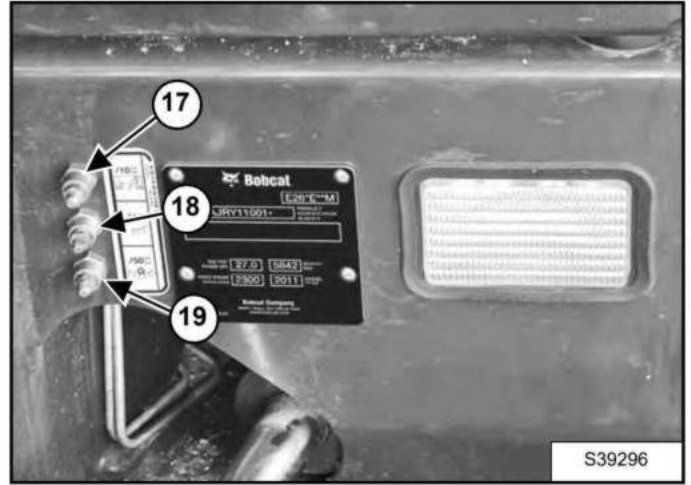

- 17. Boom Swing Cylinder Base (1) [Figure 201].

Lubricate the following locations on the hydraulic excavator **EVERY 50 HOURS**:

- 18. Slew Circle (1) [Figure 201].
- 19. Slew Pinion (1) [Figure 201]. (Install three to four pumps of grease then rotate the upperstructure 90°. Install three to four pumps of grease and again rotate the upperstructure 90°. Repeat this until the slew pinion has been greased at four positions.)

Dealer Copy -- Not for Resale

PIVOT PINS

Inspection And Maintenance

Figure 202

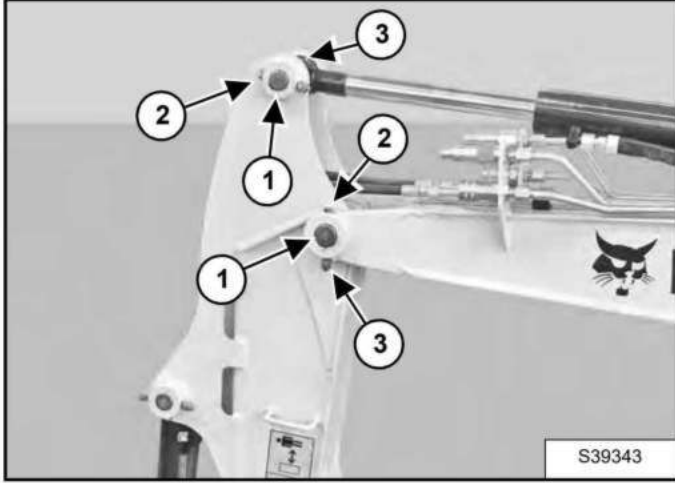

The pivots and cylinders (Item 1) have a large pin held in position with a bolt (Item 2) and double nuts (Item 3) [Figure 202] securing the pin.

The two nuts (Item 3) are used as jam nuts to hold the bolt (Item 2) without tightening the bolt (Item 2) to the pin boss. After the nuts (Item 3) are tightened together, the bolt (Item 2) [Figure 202] should be free to spin. See your Bobcat dealer for replacement parts.

EXCAVATOR STORAGE AND RETURN TO SERVICE

Storage

Sometimes it can be necessary to store your Bobcat excavator for an extended period of time. Below is a list of items to perform before storage.

- Thoroughly clean the excavator including the engine compartment.
- Lubricate the excavator.
- Replace worn or damaged parts.
- Drive the excavator onto planks in a dry protected shelter.
- Lower the boom fully with the bucket flat on the ground.
- Put grease on any exposed cylinder rods.
- Put fuel stabilizer in the fuel tank and run the engine a few minutes to circulate the stabilizer to the pump and fuel injectors.
- Drain and flush the cooling system. Refill with premixed coolant.
- Replace all fluids and filters (engine, hydraulic).
- Replace all filters (For example: air cleaner, heater, etc.).
- Put all controls in neutral position.
- Remove the battery. Be sure the electrolyte level is correct then charge the battery. Store it in a cool dry place above freezing temperatures and charge it periodically during storage.
- Cover the exhaust pipe opening.
- Tag the machine to indicate that it is in storage condition.

Return To Service

After the Bobcat excavator has been in storage, it is necessary to follow a list of items to return the excavator to service.

- Check the engine and hydraulic oil levels; check coolant level.
- Install a fully charged battery.
- Remove grease from exposed cylinder rods.
- Check all belt tensions.
- Be sure all shields and guards are in place.
- Lubricate the excavator.
- Remove cover from exhaust pipe opening.
- Start the engine and let run for a few minutes while observing the instrument panels and systems for correct operation.
- Drive the excavator off of the planks.
- Operate machine, check for correct function.
- Stop the engine and check for leaks. Repair as needed.

Dealer Copy -- Not for Resale



Bobcat®

Dealer Copy -- Not for Resale

SYSTEM SETUP AND ANALYSIS

DIAGNOSTIC SERVICE CODES	131
Service Codes List	131
DISPLAY CONTROLLER PANEL SETUP	133
Passwords	133
Password Entry (For Starting And Operating The Machine)	133
Changing The Operator Password	133
Password Lockout Feature	134
Job Clock	134
RPM	134
MAINTENANCE CLOCK	135
Description	135
Setup	135
Reset	135



Bobcat®

Dealer Copy -- Not for Resale

DIAGNOSTIC SERVICE CODES

Service Codes List

CODE		CODE	
C0216	Hydraulic / hydrostatic filter not connected	C2102	Glow plugs error ON
C0217	Hydraulic / hydrostatic filter plugged	C2103	Glow plugs error OFF
C0309	Battery voltage low	C2202	Starter error ON
C0310	Battery voltage high	C2203	Starter error OFF
C0311	Battery voltage extremely high		
C0314	Battery voltage extremely low	C2305	Offset base solenoid short to battery
C0315	Battery voltage shutdown level	C2306	Offset base solenoid short to ground
C0322	Battery voltage out of range low	C2307	Offset base solenoid open circuit
C0414	Oil pressure extremely low	C2405	Offset rod solenoid short to battery
C0415	Oil pressure shutdown level	C2406	Offset rod solenoid short to ground
		C2407	Offset rod solenoid open circuit
C0610	Engine speed high		
C0611	Engine speed extremely high	C2505	Offset return short to battery
C0613	Engine speed no signal	C2506	Offset return short to ground
C0615	Engine speed shutdown level	C2507	Offset return open circuit
C0618	Engine speed out of range high		
		C2605	Auxiliary base solenoid short to battery
C0710	Hydraulic oil temperature high	C2606	Auxiliary base solenoid short to ground
C0711	Hydraulic oil temperature extremely high	C2607	Auxiliary base solenoid open circuit
C0715	Hydraulic oil temperature shutdown level		
C0721	Hydraulic oil temperature out of range high	C2705	Auxiliary rod solenoid short to battery
C0722	Hydraulic oil temperature out of range low	C2706	Auxiliary rod solenoid short to ground
		C2707	Auxiliary rod solenoid open circuit
C0810	Engine coolant temperature high		
C0811	Engine coolant temperature extremely high	C2805	Hydraulic exchange error ON
C0815	Engine coolant temperature shutdown level	C2806	Hydraulic exchange error OFF
C0821	Engine coolant temperature out of range high		
C0822	Engine coolant temperature out of range low	C3028	Controller memory failure (Log only)
C0921	Fuel level out of range high	C3128	Interrupted power failure (Log only)
C0922	Fuel level out of range low		
		C3323	Main controller not programmed
C1221	Front auxiliary control out of range high		
C1222	Front auxiliary control out of range low	C3397	Main controller programmed (Log only)
C1223	Front auxiliary control not in neutral		
		C4321	Load sense pressure out of range high
C1305	Fuel shut-off hold solenoid short to battery	C4322	Load sense pressure out of range low
C1306	Fuel shut-off hold solenoid short to ground		
C1307	Fuel shut-off hold solenoid open circuit	C4516	Throttle controller not connected
C1402	Fuel pull solenoid short error on	C6021	Offset controller out of range high
C1403	Fuel pull solenoid short error off	C6022	Offset controller out of range low
		C6023	Offset controller not in neutral
C2005	Two speed solenoid error ON		
C2006	Two speed solenoid error OFF	C6204	Load moment in error

Dealer Copy -- Not for Resale

DISPLAY CONTROLLER PANEL SETUP

Passwords

All new machines with keyless option arrive at the Bobcat Dealerships with the panel in locked mode. This means that a password must be used to start the engine.

For security purposes, your dealer can change the password and also set it in the locked mode. Your dealer will provide you with the password.

Master Password:

A permanent, randomly selected password is set at the factory which cannot be changed. This password is used for service by the Bobcat dealer if the Owner Password is not known; or to change the Owner Password.

Owner Password:

There is only one Owner Password (**Code 0**). It must be used to change the owner or operator passwords. See below for changing the Owner Password.

Operator Password:

There can be up to three operator Passwords (**Code 1, Code 2, Code 3**). See below for changing the Operator Password.

Password Entry (For Starting And Operating The Machine)

Press ENTER CODE button (Item 1). The panel will become lighted and there will be two short beeps. **Code** will appear on the display screen (Item 2) [Figure 203].

NOTE: After you press ENTER CODE you have 40 seconds to use the keypad (Item 3) [Figure 203] to enter the password. (If more than 40 seconds is used, the process will abort and you will need to start over.

Enter the password. For each digit that you enter, a dash will appear on the display screen. If the password was entered correctly, there will be one long beep.

NOTE: If the password was incorrect there will be three short beeps and "Error" will appear on the display screen. Press the ENTER CODE button again and start over. After three failed attempts, you must wait three minutes to try again.

You are now ready to start and operate the machine.

If you will be changing the operator password, do not start the engine. (See Changing The Operator Password on Page 133.)

Changing The Operator Password

Figure 203

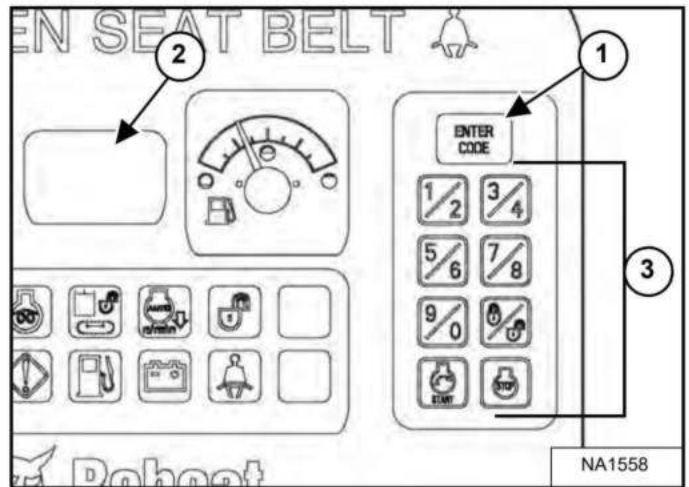

Perform Password Entry at left, but do not start the engine.

Press and hold the ENTER CODE button (Item 1) for 3 seconds. Code 1 will appear on the display screen (Item 2) [Figure 203].

Press the ENTER CODE button until the desired Code (**Code 0, Code 1, Code 2, Code 3**) appears. Code 0 is Owner Password, the other codes are Operator passwords. You now have 40 seconds to use the keypad (Item 3) [Figure 203] to enter each digit of a new four digit password.

Enter the new four digit password. After the fourth digit is entered, there will be two short beeps and **rPEAt** will appear.

Re-enter the new four digit password to verify. If the new passwords match, there will be two short beeps, **Code** will appear for 1 second and then the display screen will return to HOURMETER function.

NOTE: If the new passwords do not match, there will be one long beep and "Error" will appear for 1 second and then the display screen will return to HOURMETER function.

Dealer Copy -- Not for Resale

DISPLAY CONTROLLER PANEL SETUP (CONT'D)

Password Lockout Feature

This allows the operator to Unlock the password feature so that a password does not need to be used every time you start the engine.

Perform Password Entry (See Password Entry (For Starting And Operating The Machine) on Page 133.) (the engine can be started or stopped.) The password entry can be performed with the engine off or with the engine running.

Figure 204

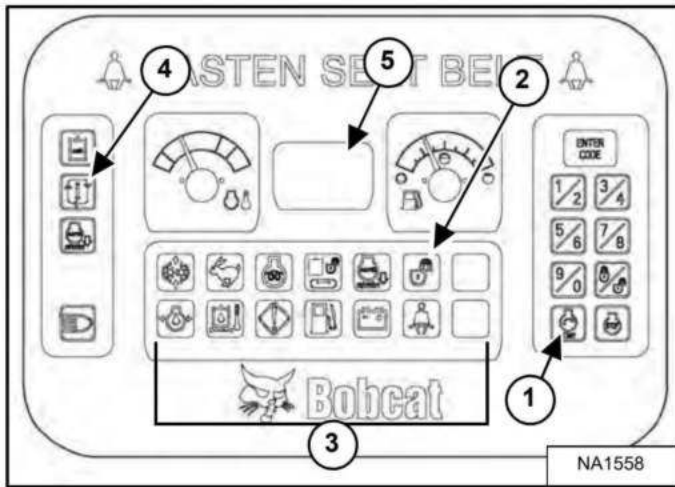

Press the Lock / Unlock button (Item 1). The display screen (Item 5) [Figure 204] will continuously alternate from **UnLoc** to **Code** for 1 second periods.

Perform Password Entry again.

UnLoc will appear in the display screen (Item 5), the Unlocked Icon (Item 2) will appear in the Icon Display Area (Item 3) [Figure 204] and there will be two short beeps.

To start an Unlocked system, press the ENTER CODE button and press the START button.

When you stop the engine with the system unlocked, you will hear one long beep every 3 seconds for 15 seconds.

To lock the system again, press the Lock / Unlock button (Item 1) [Figure 204] and enter the password during the 15 second period.

Job Clock

The JOB CLOCK can be set to record accumulated hours for a particular job.

Press and release the information button (Item 4) until JOB light is ON at the top, center of the display screen (Item 5) [Figure 204].

While the JOB light is ON, press and hold the information button (Item 4) [Figure 204] until the display screen returns to zero.

This process will clear the accumulated hours and will begin recording JOB CLOCK time again. (This does not affect the HOURMETER which continues to record the total operating hours of the excavator.)

Pressing the information button (Item 1) [Figure 204] again or pressing the START button will return the display screen to HOURMETER function.

RPM

The display screen (Item 5) [Figure 204] can be set to display engine rpm.

With the engine running, press and release the information button (Item 4) until rpm light is ON at the top, center of the display screen (Item 5) [Figure 204].

Engine rpm is now displayed on the display screen.

Press the information button (Item 4) [Figure 204] again the return to HOURMETER function.

MAINTENANCE CLOCK

Description

The Maintenance Clock alerts the operator when the next service interval is due. *EXAMPLE:* The Maintenance Clock can be set to a 250 hour interval as a reminder for the next 250 hour planned maintenance.

Figure 205

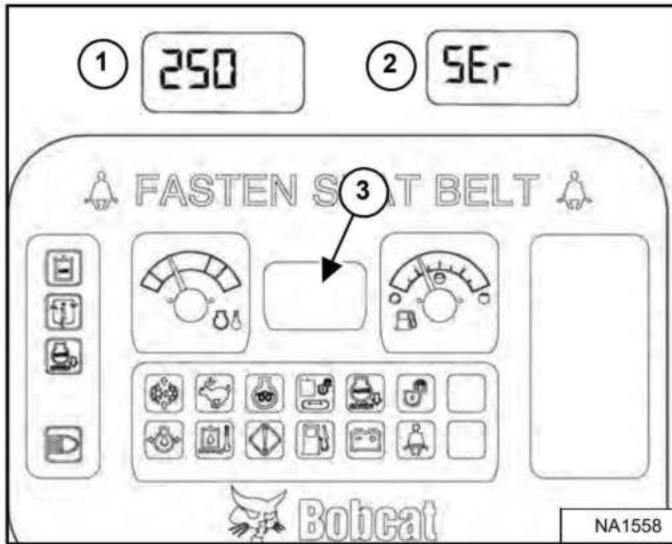

During machine operation, a two beep alarm will sound when there are less than 10 hours until the next planned maintenance.

The hours interval (Item 1) and the [SEr] (Item 2) will alternate in the data display screen (Item 3) [Figure 205] for 10 seconds.

The display will then revert back to the previous display and will appear for 10 seconds every time the machine is started until the maintenance clock is reset.

Setup

See your Bobcat dealer about installation of this feature.

Reset

Figure 206

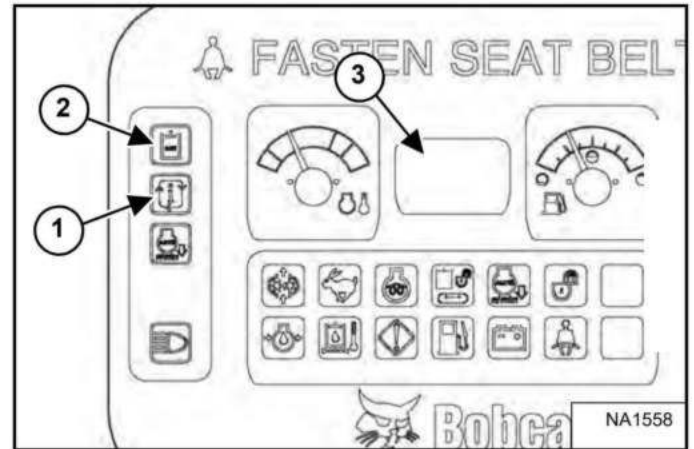

To reset the panel after the scheduled maintenance is completed, do the following:

Turn the key to the OFF position or press the stop button (keyless panel).

Press the information button (Item 1) [Figure 206] to turn the panel on.

Press and hold the information button (Item 1) and the auxiliary hydraulic button (Item 2) simultaneously until [rESEt] appears in the data display screen (Item 3) [Figure 206].

Dealer Copy -- Not for Resale



Bobcat®

Dealer Copy -- Not for Resale

MACHINE SIGN TRANSLATIONS

MACHINE SIGN TRANSLATIONS	139
Service Schedule (7188747)	139
Warning (7178178)	142
Lift Chart (7206148) With Standard Arm	143
Lift Chart (7206149) With Standard Arm and Additional Counterweight	146
Lift Chart (7206150) With Long Arm and Additional Counterweight	149
Warning (7148157)	152
Warning (7178177)	154
Warning (6708929)	157
Warning (6809832)	157
Warning (6804233)	157
Warning (7148145)	158
Warning (7148147)	158
Using the Pin-On X-Change (6818059)	159
Joystick Control Pattern Selector Lever (7178179)	162
Warning (6737189)	163
Warning (7169006)	163



Bobcat®

Dealer Copy -- Not for Resale

WARNING

- **AVOID INJURY OR DEATH**
- Keep cover closed except for service.
- Keep engine clean of flammable material.
- Keep body, loose objects and clothing away from electrical contacts, moving parts, hot parts and exhaust.
- Do not use machine in space with explosive dust or gases or with flammable material near exhaust.
- All exhaust gases can kill. Always ventilate.
- Never use ether or starting fluid on diesel engine. Use only starting aids as approved by engine manufacturer.
- Leaking fluids under pressure can enter skin and cause serious injury. Immediate medical attention is required. Wear goggles. Use cardboard to check for leaks.
- Battery acid causes severe burns. Wear goggles. If acid contacts eyes, skin or clothing, flush and get medical attention.
- Battery makes flammable and explosive gas. Keep arcs, sparks, flames and lighted tobacco away.
- For jump start, connect negative cable to the machine frame last (never at the battery). After jump start, remove negative connections at the frame first.

SERVICE SCHEDULE

- Service at first 50 hours, then as scheduled.
 - Service every 10 hours when operating in water.
- EVERY 8-10 HOURS**
- Check engine coolant level.
 - Check engine oil level.
 - Check hydraulic fluid level.
 - Check air cleaner condition indicator.
 - Check and adjust track tension.
 - Check indicator lights for correct operation.
 - Check horn and motion alarm (if equipped) for proper function.
 - Grease all machinery pivot points. (See illustrations)
 - Check cab and HVAC filters - clean as needed.
 - Check cab/canopy condition and mounting hardware.
 - Check seat belt condition and mounting hardware.
 - Check control console lockout for proper operation.
 - Check for damaged signs (decals) - Replace as needed.
 - Grease Hydraulic clamp and Angle blade if equipped.
 - Check X-Change (if equipped) for damage and loose parts.
- EVERY 50 HOURS**
- Grease swing pinion and swing circle. (See illustrations)
 - Check battery, cables and electrolyte level.
 - Drain water and sediment from fuel tank and fuel filter.
- EVERY 100 HOURS**
- Spark Arrestor Muffler - Clean spark chamber.
 - Check and adjust V-Belt. Replace as needed. (E26)
- EVERY 250 HOURS**
- Check oil level in both final drive cases.
 - Replace Diesel fuel filter.
 - Change engine oil and filter. (Model E26)
- EVERY 500 HOURS**
- Change engine oil and filter. (Model E32, E35, E42, E45, E50, E55)
 - Clean radiator, oil cooler and A/C condenser.
 - Replace primary hydraulic and case drain filter and reservoir breather.
 - Check alternator and starter connections.
 - Check and adjust engine valve clearance.
 - Inspect ribbed belt(s) wear. Replace as needed.
- EVERY 1000 HOURS**
- Replace oil in both final drive cases.
 - Replace hydraulic fluid and filters.
- EVERY 2 YEARS**
- Drain and flush cooling system - Replace coolant.

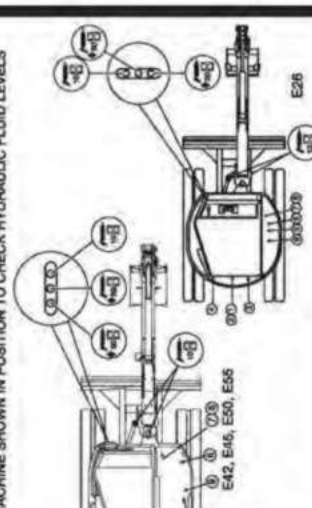
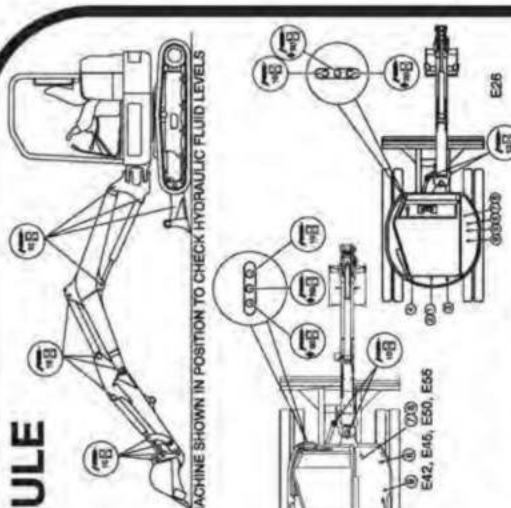

FILTER CHART

	E26	E32 / E35	E42 / E45	E50 / E55
1. PRIMARY AIR FILTER	6672467	6672467	6666375	6666375
2. SECONDARY AIR FILTER	6672468	6672468	6666376	6666376
3. ENGINE OIL FILTER	6657635	6675517	6675517	6675517
4. FUEL FILTER	6667352	6667352	6667352	6667352
5. PRIMARY HYDRAULIC FILTER	6661248	6668819	6668819	6670207
6. CASE DRAIN HYDRAULIC FILTER	7009365	7009365	6516722	6516722
7. RECONDITION FILTER	7010332	7010332	7010332	7010332
8. FRESH AIR FILTER	7010331	7010331	7010331	7010331
9. BREATHER FILTER	6692836	6692836	6692836	6692836

IMPORTANT

THIS MACHINE IS FACTORY EQUIPPED WITH A U.S.A. FORESTRY SERVICE APPROVED SPARK ARRESTOR MUFFLER.

IT IS NECESSARY TO CLEAN THIS SPARK ARRESTOR MUFFLER TO KEEP IT IN WORKING CONDITION. THE SPARK ARRESTOR MUFFLER MUST BE SERVICED BY DUMPING THE SPARK CHAMBER EVERY 100 HOURS OF OPERATION.

IF THIS MACHINE IS OPERATED ON FLAMMABLE FOREST, BRUSH OR GRASS COVERED LAND, IT MUST BE EQUIPPED WITH A SPARK ARRESTOR ATTACHED TO THE EXHAUST SYSTEM AND MAINTAINED IN WORKING ORDER. FAILURE TO DO SO WILL BE IN VIOLATION OF CALIFORNIA STATE LAW, SECTION 4462, PRC.

REFER TO LOCAL LAWS AND REGULATIONS FOR SPARK ARRESTOR REQUIREMENTS.

See Operation & Maintenance Manual for more information and instructions. 80112 SW 7188747A enUS
© 2011 Deere & Company

ADVERTENCIA

EVITE LESIONES O FATALIDADES

- Mantenga la cubierta cerrada, salvo para dar servicio.
- Mantenga el motor libre de material inflamable.
- Mantenga el cuerpo, objetos y ropa holgada alejados de contactos eléctricos, partes que se mueven, partes calientes y el escape.
- No utilice la máquina en un espacio con polvo o gases explosivos, o con material inflamable cerca del escape.
- Todos los gases de escape pueden matar. Ventílle siempre.
- Nunca utilice éter o líquidos de arranque en motores diesel con bujías de precalentamiento. Utilice solo ayudas de arranque aprobadas por el fabricante del motor.
- Los líquidos que se fugan a presión pueden penetrar la piel y provocar lesiones graves. Se requiere atención médica inmediata. Use gafas de seguridad. Utilice cartón para revisar la presencia de fugas.
- El ácido de la batería provoca quemaduras graves. Use gafas de seguridad. Si el ácido hace contacto con los ojos, piel o ropa, lave bien y busque atención médica.
- La batería crea gases inflamables y explosivos. Mantener arcos, chispas, llamas y tabaco/cigarrillo encendido alejados.
- Para arranques en puente, conecte de último el cable negativo en el motor de la máquina (nunca en la batería). Después del arranque en puente, retire primero la conexión negativa del motor.

PROGRAMA DE MANTENIMIENTO

- De servicio a las primeras 50 horas, luego según lo programado.
- De servicio cada 10 horas cuando opere en agua.

CADA 8-10 HORAS

- Revise el nivel del enfriador del motor.
- Revise el nivel del aceite de motor.
- Revise el nivel del fluido hidráulico.
- Revise el indicador de condición del depurador de aire.
- Revise y ajuste la tensión de la correa.
- Revise que las luces indicadoras funcionen adecuadamente.
- Encese que la bocina y alarma de movimiento (si están equipadas) funcionen adecuadamente.
- Encese todos los puntos de pivote de la maquinaria. (Ver ilustraciones)
- Revise los filtros de la cabina y HVAC - limpiar si es del caso.
- Revise la condición de la capricubierta y el tirante de fijación.
- Revise la condición del cinturón de seguridad y el tirante de fijación.
- Revise que el seguro de la consola de control funcione adecuadamente.
- Revise la presencia de calcomanías averiadas - reponer si es del caso.
- Encese la montaza hidráulica y la pala de ángulo, si están equipadas.
- Revise que el X-Change (si está equipado) no esté averiado y tenga pannes líquas.

CADA 50 HORAS

- Encrase el piñón de giro y el piñón de la cremallera del tornamesa.
- Revise la batería, cables y nivel electrolítico.
- Drene el agua y sedimento del tanque de combustible y del filtro de combustible.

CADA 100 HORAS

- Sincronice el sistema paracheque - limpie el cámara de cheque.
- Repare y ajuste la correa en V. Reponer, si es del caso. (E28)

CADA 250 HORAS

- Revise el nivel de aceite en ambos cajas de transmisión final.
- Cambie el filtro de combustible diesel.
- Cambie el aceite y filtro del motor. (Modelo E28).

CADA 500 HORAS

- Cambie el aceite y filtro del motor. (Modelo E32, E35, E42, E50, E55)
- Limpie el radiador, enfriador de aceite y condensador del aire acondicionado. Cambie el filtro primario hidráulico y de la caja de drenaje y el desfogue del reservorio.
- Revise las conexiones del alternador y arrancador.
- Revise y ajuste la holgura de la válvula del motor.
- Inspeccione que los (s) correa(s) no estén (s) desgastada(s). Reponer, si es del caso.

CADA 1000 HORAS

- Cambie el aceite de ambos cajas de transmisión final.
- Cambie el fluido y los filtros hidráulicos.

CADA 2 AÑOS

- Drene y purgue el sistema de engranamiento - reponer el enfriador.

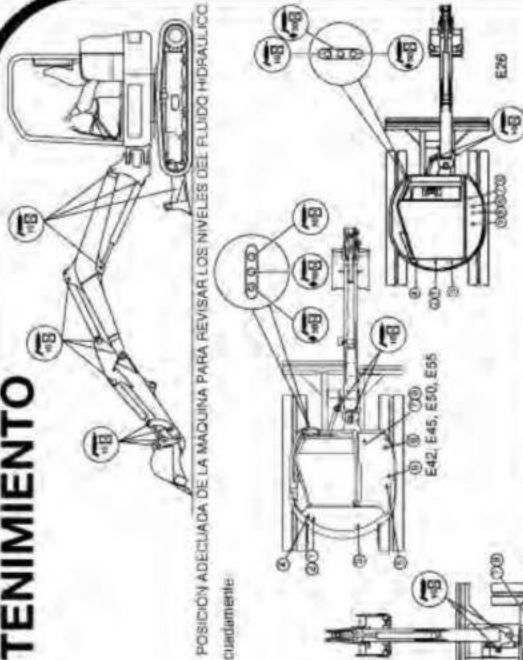

POSICIÓN ADECUADA DE LA MÁQUINA PARA REVISAR LOS NIVELES DEL FLUIDO HIDRÁULICO

	E26	E32 / E35	E42 / E45	E50 / E55
1. FILTRO DE AIRE PRIMARIO	6672467	6672467	6666375	6666375
2. FILTRO SECUNDARIO	6672468	6672468	6666376	6666376
3. FILTRO DE ACEITE DEL MOTOR	6667635	6675517	6675517	6675517
4. FILTRO DE COMBUSTIBLE	6667352	6667352	6667352	6667352
5. FILTRO HIDRÁULICO PRIMARIO	6661248	6668819	6668819	6670207
6. HIDRÁULICO DE CAJA DE TRANSMISIÓN	7009365	7009365	6516722	6516722
7. FILTRO DE PURIFICACIÓN	7010332	7010332	7010332	7010332
8. FILTRO DE AIRE FRESCO	7010331	7010331	7010331	7010331
9. FILTRO DE DESFOGUE	6692836	6692836	6692836	6692836

IMPORTANTE

ESTA MÁQUINA ESTÁ EQUIPADA DE FABRICA CON UN SILENCIADOR DEL SISTEMA PARACHISPAS APROBADO. SI NECESITA LIMPIAR EL SILENCIADOR PARA MANTENERLO EN CONDICIONES DE TRABAJO, ADEMÁS DEBE DARLE SERVICIO YACIENDO LA CÁMARA DE CHISPAS CADA 100 HORAS DE OPERACIÓN.

ESTA MÁQUINA SE UTILIZA EN ZONAS INFLAMABLES, MATRIBALES O EN LOS CUBIERTOS DE GRAMA. DEBE EQUIPARSE CON UN PARACHISPAS SUJETO AL SISTEMA DE ESCAPE Y MANTENERSE EN CONDICIONES DE TRABAJO DE LO CONTRARIO REPRESENTA UNA VIOLACIÓN DE LA LEY ESTATAL DE CALIFORNIA, SECCIÓN 444, PRC.

REFERIRSE A LAS LEYES Y REGLAMENTOS LOCALES PARA CONOCER LOS REQUISITOS DE PARACHISPAS.

Consulte más información e instrucciones en el Manual de operación y mantenimiento.

80112 SW 7188747A esAR

Ver las abreviaturas de los filtros en las abreviaturas arriba.

AVERTISSEMENT

RISQUE DE BLESSURES OU DE MORT

- Gardez le capot fermé sauf pour l'entretien.
- Débarrassez le moteur de tout matériel inflammable.
- Maintenez le corps, les objets et les vêtements lâches à l'écart des contacts électriques, des pièces mobiles, des pièces brûlantes et de l'échappement.
- N'utilisez pas la machine dans des lieux contenant des poussières ou des gaz explosifs ou avec des matériaux inflammables à proximité de l'échappement.
- Tous les gaz d'échappement sont mortels. Veillez à toujours aérer la zone.
- N'utilisez jamais d'éther ou de liquide de démarrage sur un moteur diesel. Utilisez uniquement des aides au démarrage approuvées par le fabricant du moteur.
- En cas de fuite de fluides sous pression, ceux-ci peuvent pénétrer dans la peau et provoquer des blessures graves. Dans ce cas, consultez immédiatement un médecin. Portez des lunettes de protection. Utilisez un morceau de carton pour repérer les fuites.
- L'acide d'une batterie provoque des brûlures graves. Portez des lunettes de protection. En cas de contact des yeux, de la peau ou des vêtements avec de l'acide, rincez bien et consultez un médecin.
- La batterie génère des gaz inflammables et explosifs. Maintenez-la à l'écart des arcs, des étincelles, des flammes et des cigarettes allumées.
- En cas de démarrage forcé, connectez le câble négatif au châssis de la machine en dernier (jamais à la batterie). Après un démarrage forcé, retirez en premier les connexions négatives au cadre.

TABLEAU DES ENTRETIENS

Effectuez l'entretien après 50 heures, puis selon le tableau.

Effectuez l'entretien toutes les 10 heures lors de l'utilisation dans l'eau.

TOUTES LES 6-10 HEURES

- Vérifiez le niveau du liquide de refroidissement du moteur.
- Vérifiez le niveau d'huile moteur.
- Vérifiez le niveau du fluide hydraulique.
- Vérifiez l'indicateur d'état du filtre à air.
- Vérifiez et réglez la tension des chaînes.
- Vérifiez le bon fonctionnement des lumières lumineuses.
- Vérifiez les points pivots de la machine. (Consultez les illustrations.)
- Vérifiez l'état de la cabine/du cadre de protection et de la visserie de fixation.
- Vérifiez l'état de la ceinture de sécurité et de ses fixations.
- Vérifiez le bon fonctionnement du verrouillage de la console.
- Vérifiez que les autocollants ne sont pas abîmés. Remplacez-les au besoin.
- Graissez la pince hydraulique et la lame articulée, le cas échéant.
- Vérifiez la chaîne d'entraînement X (le cas échéant) pour la présence de dommages ou de pièces desserrées.

TOUTES LES 50 HEURES

- Lubrifiez le pignon et le cercle d'oscillation. (Consultez les illustrations.)
- Vérifiez les barres, les câbles et le niveau d'électrolyte.
- Purgez le réservoir de carburant et le filtre d'alimentation de l'eau et des sédiments.

TOUTES LES 100 HEURES

- Silencieux pare-étincelles - Videz la chambre à étincelles.
- Vérifiez l'usage et ajustez au besoin la courroie trapézoïdale.
- Remplacez-la au besoin. (E26)

TOUTES LES 250 HEURES

- Contribuez le niveau d'huile dans les deux cariers à l'entraînement.
- Remplacez le filtre du carburant dilaté.
- Changez l'huile et le filtre à huile moteur. (Modèle E26)

TOUTES LES 500 HEURES

- Remplacez l'huile et le filtre moteur. (Modèles E32, E35, E42, E45, E50, E55)
- Nettoyez le radiateur, le refroidisseur d'huile et le condenseur de climatisation. Remplacez le filtre hydraulique primaire et le filtre de retour du carter et le reniflard de réservoir.
- Vérifiez les connexions de l'alternateur et du démarreur.
- Vérifiez et réglez le jeu des soupapes du moteur.
- Inspectez la ou les courroies sèches pour la présence d'usure. Remplacez-les au besoin.

TOUTES LES 1 000 HEURES

- Remplacez l'huile dans les deux cariers de réduction finale.
- Remplacez le fluide et les filtres hydrauliques.

TOUS LES 2 ANS

- Videz et rincez le circuit de refroidissement.
- Remplacez la trappe de refroidissement.

IMPORTANT

CETTE MACHINE EST ÉQUIPÉE EN USINE D'UN SILENCIEUX PARE-ÉTINCELLES APPROUVÉ PAR LE SERVICE DES FORÊTS DES ÉTATS-UNIS (U.S.A. FORESTRY SERVICE). IL EST INDISPENSABLE DE NETTOYER DE SILENCIEUX APN DE LE MAINTENIR EN BON ÉTAT DE FONCTIONNEMENT. CET ENTRETIEN CONSISTE À VIDER LA CHAMBRE À ÉTINCELLES TOUTES LES 100 HEURES D'UTILISATION.

SI CETTE MACHINE EST UTILISÉE EN ZONE DE FORÊTS, DE BROUSSAILLES OU D'HERBAGES PRÉSENTANT DES RISQUES D'INCENDIE, ELLE DOIT ÊTRE ÉQUIPÉE D'UN PARE-ÉTINCELLES AJOUTÉ AU CIRCUIT D'ÉCHAPPEMENT EN OUTRE EN BON ÉTAT DE MARCHE. LE NON RESPECT DE CETTE OBLIGATION CONTRIBUE À LA LOI DE LETY DE CHAUFFORNE, SECTION 4142, PRC.

REPORTEZ-VOUS AUX RECOMMANDATIONS LOCALES POUR LES EXIGENCES APPLICABLES DANS VOTRE CAS EN MATIÈRE DE PARE-ÉTINCELLES.

TABLEAU DES FILTRES

	E26	E32 / E35	E42 / E45	E50 / E55
1. FILTRE À AIR PRIMAIRE	6672467	6672467	6666375	6666375
2. FILTRE À AIR SECONDAIRE	6672468	6672468	6666376	6666376
3. FILTRE À VALE MOTEUR	6657635	6675517	6675517	6675517
4. FILTRE À CARBURANT	6667352	6667352	6667352	6667352
5. FILTRE HYDRAULIQUE PRIMAIRE	6661248	6668819	6668819	6670207
6. FILTRE HYDRAULIQUE SECONDAIRE	7009365	7009365	6516722	6516722
7. FILTRE DE RECHARGEMENT	7010332	7010332	7010332	7010332
8. FILTRE À AIR PHAS	7010331	7010331	7010331	7010331
9. FILTRE RENIFLARD	6692836	6692836	6692836	6692836

- Consultez les illustrations et-dessus pour les emplacements de filtres.

80112 SW 7188747A fCA

MACHINE SIGN TRANSLATIONS (CONT'D)

Warning (7178178)

 WARNING	
Improper loading, transporting and lifting procedures can cause serious injury or death.	
<p style="text-align: center;">TRANSPORTING MACHINE</p> <ul style="list-style-type: none">• Use metal loading ramps with sides and slip resistant surfaces.• Secure ramps to truck bed.• Engage truck parking brake and block truck tires.• Ramp angle must not exceed 15°.• Top of ramp must be level with truck bed.• Engage swing lock (if equipped).• Secure machine with tie downs and block tracks.  <p style="text-align: right;">75464 SW 7178178A enUS © 2011 CNH GLOBAL CORP. ALL RIGHTS RESERVED.</p>	<p style="text-align: center;">LIFTING MACHINE</p> <ul style="list-style-type: none">• Lifting device must have adequate capacity to lift machine.• Maintain center of gravity and balance.• Position machine as shown. Engage the swing lock (if equipped).• Never lift with operator on machine.  <p style="text-align: right;">SW 01 5808185 AR</p>

 ADVERTENCIA	
Ejecutar procedimientos de carga, transporte y elevación no adecuados puede causar lesiones serias o accidentes fatales.	
<p style="text-align: center;">TRANSPORTE DE LA MÁQUINA</p> <ul style="list-style-type: none">• Utilice rampas de carga metálicas con costados y superficies antideslizantes.• Asegure las rampas a la plataforma de apoyo del camión.• Enganche el freno de estacionamiento del camión y bloquee los neumáticos del mismo.• El ángulo de la rampa no debe exceder los 15°.• La parte superior de la rampa debe estar nivelada con la plataforma de apoyo del camión.• Enganche el seguro de giro (si viene equipado).• Asegure la máquina con amarres y bloquee las orugas.  <p style="text-align: right;">41742</p>	<p style="text-align: center;">ELEVACIÓN DE LA MÁQUINA</p> <ul style="list-style-type: none">• El dispositivo de elevación debe tener la capacidad adecuada para elevar la máquina.• Mantenga el centro de gravedad y balance.• Posicione la máquina como se muestra.• Enganche el seguro de giro (si viene equipado).• Jamás eleve con un operador en la máquina.  <p style="text-align: right;">SW 01 5808185 AR</p>

 AVERTISSEMENT	
Le non respect des procédures de chargement, de transport et de levage peut causer des blessures graves, voire mortelles.	
<p style="text-align: center;">TRANSPORT DE LA MACHINE</p> <p>Utilisez des rampes en acier avec rebords et revêtements anti-dérapants. Attachez les rampes au plancher de la remorque. Serrez le frein de stationnement et bloquez les roues du camion. L'inclinaison de la rampe ne doit pas dépasser 15°. L'extrémité de la rampe doit se trouver dans l'alignement du plancher de la remorque. Engagez l'axe de verrouillage de l'orientation. Attachez la machine avec des chaînes et bloquez les chenilles.</p>  <p style="text-align: right;">41742</p>	<p style="text-align: center;">LEVAGE DE LA MACHINE</p> <ul style="list-style-type: none">• Le dispositif de levage doit être capable de supporter le poids de la machine.• Maintenez le centre de gravité et l'équilibre pendant l'opération.• Positionnez la machine comme indiqué. Engagez l'axe de verrouillage de l'orientation.• Ne levez jamais la pelle quand l'opérateur s'y trouve.  <p style="text-align: right;">DV-00-5808185-FR</p>

Dealer Copy -- Not for Resale

Lift Chart (7206148) With Standard Arm

EXCAVATOR MODEL E26

ARM LENGTH: 1100 mm (43.3 in)
STANDARD BUCKET: 508 mm (20.0 in)
84 kg (185 lb)
X-CHANGE QUICK-TACH

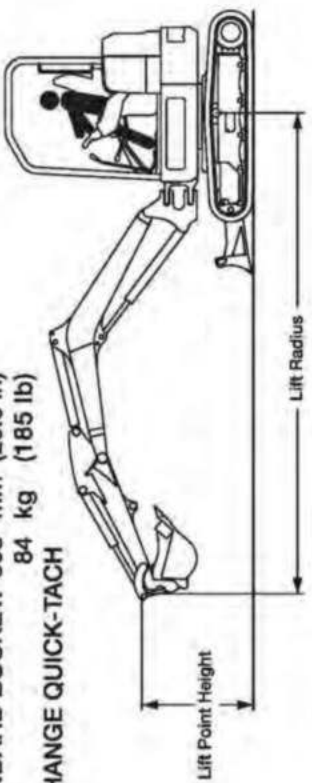

Lift Point Height Lift Radius

LIFT POINT HEIGHT	RATED LIFT CAPACITY OVER BLADE, BLADE DOWN - kg (lb)			RATED LIFT CAPACITY OVER BLADE, BLADE UP - kg (lb)			RATED LIFT CAPACITY OVER SIDE, BLADE UP - kg (lb)		
	LIFT RADIUS - mm (in)			LIFT RADIUS - mm (in)			LIFT RADIUS - mm (in)		
	2000 (78.7)	3000 (118.1)	4000 (157.5)	2000 (78.7)	3000 (118.1)	4000 (157.5)	2000 (78.7)	3000 (118.1)	4000 (157.5)
3000 (118.1)	*446 (983)	*504 (1111) @3230 (127.2)	*527 (1162) @3840 (151.2)	*427 (941)	324 (714) @3230 (127.2)	332 (732)	295 (650) @3230 (127.2)	331 (730)	207 (456) @3840 (151.2)
2000 (78.7)	*532 (1173)	*562 (1239) @4030 (158.7)	*569 (1254)	401 (884)	249 (549) @3840 (151.2)	331 (730)	207 (456) @3840 (151.2)	331 (730)	207 (456) @3840 (151.2)
1000 (39.4)	*765 (1687)	*611 (1347) @3880 (152.8)	*611 (1347) @3880 (152.8)	381 (840)	228 (503) @4030 (158.7)	310 (683)	182 (401) @4030 (158.7)	310 (683)	182 (401) @4030 (158.7)
Ground	*1731 (3816)	*906 (1997)	*805 (1775)	805 (1775)	247 (545) @3880 (152.8)	293 (646)	192 (423) @3880 (152.8)	293 (646)	192 (423) @3880 (152.8)
-1000 (-39.4)	*1665 (3671)	*818 (1803)	927 (2044)	927 (2044)	348 (767) @3320 (130.7)	300 (661)	255 (562) @3320 (130.7)	300 (661)	255 (562) @3320 (130.7)

WARNING



OVERLOAD CAN TIP THE EXCAVATOR AND CAUSE INJURY OR DEATH

- Do not lift or hold any load that exceeds these ratings at their specified load radii and height.
- Total rated load is shown. The weight of all lifting devices must be deducted to determine the net load that can be lifted.

Where applicable, specifications conform to ISO Standards. Specifications are subject to change without notice. Lift Point is bucket hinge point with standard bucket attached and bucket cylinder fully extended.

80623 SW 7206148 enUS

* Rated Hydraulic Lift Capacity

EXCAVATRICE MODÈLE E26

LONGUEUR DU BALANCIER : 1 100 mm (43,3 po)
 GODET STANDARD: 508 mm (20,0 po)
 84 kg (185 lb)

X-CHANGE QUICK-TACH

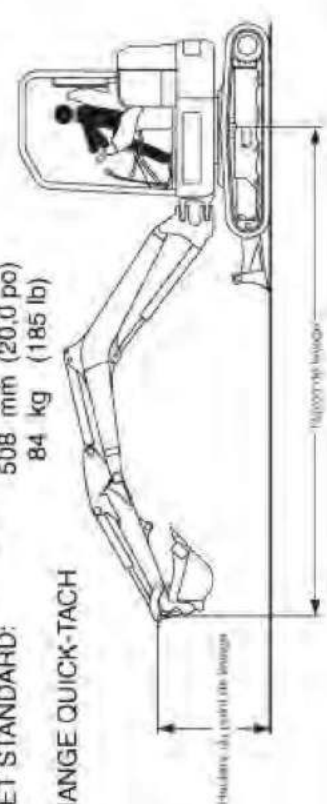

Hauteur du point de levage
Rayon de levage

HAUTEUR DU POINT DE LEVAGE	CAPACITÉ DE LEVAGE EXTREMITÉ LAME, CELLE-CI ÉTANT BAISSÉE - kg (lb)			CAPACITÉ DE LEVAGE EXTREMITÉ LAME, CELLE-CI ÉTANT RELEVÉE - kg (lb)			CAPACITÉ DE LEVAGE LATÉRAL, AVEC LA LAME RELEVÉE - kg (lb)		
	RAYON DE LEVAGE - mm (po)			RAYON DE LEVAGE - mm (po)			RAYON DE LEVAGE - mm (po)		
	2 000 (78,7)	3 000 (118,1)	4 000 (157,5)	2 000 (78,7)	3 000 (118,1)	4 000 (157,5)	2 000 (78,7)	3 000 (118,1)	4 000 (157,5)
3 000 (118,1)	*446 (983)	*504 (1 111) à 3 230 (127,2)	*527 (1 162) à 3 840 (151,2)	*427 (941)	324 (714) à 3 230 (127,2)	332 (732)	295 (650) à 3 230 (127,2)	331 (730)	207 (456) à 3 840 (151,2)
2 000 (78,7)	*532 (1 173)	*569 (1 254)	*511 (1 139) à 4 030 (158,7)	401 (884)	249 (549) à 3 840 (151,2)	310 (683)	182 (401) à 4 030 (158,7)	184 (406)	192 (423) à 3 880 (152,0)
1 000 (39,4)	*765 (1 687)	*906 (1 997)	*661 (1 457) à 3 320 (130,7)	381 (840)	228 (503) à 4 030 (158,7)	293 (646)	255 (562) à 3 320 (130,7)	300 (661)	255 (562) à 3 320 (130,7)
Au niveau du sol	*1665 (3 671)	*818 (1 803)		406 (895)	348 (767) à 3 320 (130,7)	619 (1 365)			
-1 000 (-39,4)				927 (2 044)					

AVERTISSEMENT

TOUTE SURCHARGE PEUT ENTRAÎNER LE RENVÈRSEMENT DE L'EXCAVATRICE ET PROVOQUER DES BLESSURES GRAVES, VOIRE MORTELLES

- Ne jamais lever ni porter de charges qui dépassent des capacités au rayon et à la hauteur spécifiés.
- Le chiffre indique représente la charge nominale totale. Le poids de tous les équipements de levage doit être déduit pour déterminer la charge nette pouvant être soulevée.

Le cas échéant, les caractéristiques techniques sont conformes aux normes ISO. Elles peuvent être modifiées sans préavis. Le point de levage s'entend comme le point d'articulation du godet (godet standard) avec le bras de godet en extension complète.

* Capacité de levage hydraulique nominale

80623 SW 7206148 rCA

EXCAVATOR MODEL E26

ARM LENGTH: 1100 mm (43.3 in)
STANDARD BUCKET: 508 mm (20.0 in)
84 kg (185 lb)
**X-CHANGE QUICK-TACH
 ADD-ON COUNTERWEIGHT**

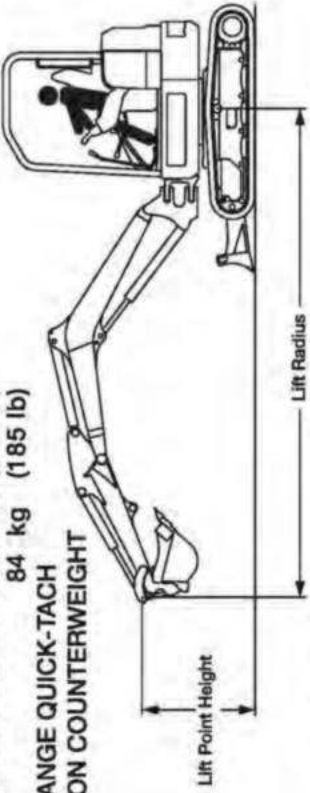

Lift Point Height Lift Radius

7206149 enUS

80623 SW

WARNING

OVERLOAD CAN TIP THE EXCAVATOR AND CAUSE INJURY OR DEATH
 Do not lift or hold any load that exceeds these ratings at their specified load radii and height.
 Total rated load is shown. The weight of all lifting devices must be deducted to determine the net load that can be lifted.

Where applicable, specifications conform to ISO Standards. Specifications are subject to change without notice. Lift Point is bucket hinge point with standard bucket attached and bucket cylinder fully extended.

LIFT POINT HEIGHT	RATED LIFT CAPACITY OVER BLADE, BLADE DOWN - kg (lb)			RATED LIFT CAPACITY OVER BLADE, BLADE UP - kg (lb)			RATED LIFT CAPACITY OVER SIDE, BLADE UP - kg (lb)		
	LIFT RADIUS - mm (in)			LIFT RADIUS - mm (in)			LIFT RADIUS - mm (in)		
	2000 (78.7)	3000 (118.1)	4000 (157.5)	2000 (78.7)	3000 (118.1)	4000 (157.5)	2000 (78.7)	3000 (118.1)	4000 (157.5)
3000 (118.1)	*459 (1012)	*508 (1120) @3230 (127.2)	*572 (1261)	*440 (970)	*478 (1054) @3230 (127.2)	*455 (1003)			350 (772) @3230 (127.2)
2000 (78.7)	*521 (1149)	*531 (1171) @3840 (151.2)	*572 (1261)	*499 (1100)	328 (723) @3840 (151.2)	399 (880)			262 (578) @3840 (151.2)
1000 (39.4)	*756 (1667)	*567 (1250) @4030 (158.7)	*572 (1261)	488 (1076)	296 (653) @4030 (158.7)	375 (827)	234 (516)		237 (522) @4030 (158.7)
Ground	*1752 (3862)	*613 (1351) @3880 (152.8)		486 (1071)	316 (697) @3880 (152.8)	777 (1713)			243 (536) @3880 (152.8)
-1000 (-39.4)	*1723 (3799)	*666 (1468) @3320 (130.7)		506 (1116)	441 (972) @3320 (130.7)	858 (1892)			319 (703) @3320 (130.7)

* Rated Hydraulic Lift Capacity

EXCAVADORA MODELO E26

LARGO DE BRAZO 1400 mm (55.1 pulgadas)
CUCHARÓN ESTÁNDAR 508 mm (20.0 pulgadas)
84 kg (185 lb)

SISTEMA X-CHANGE CON ENGANCHE RÁPIDO CON CONTRAPESOS

Altura del punto de elevación
Radio de elevación

ALTURA DEL PUNTO DE ELEVACIÓN	CAPACIDAD DE ELEV. NOMINAL SOBRE PALA, PALA ABAJO – kg (lb)			CAPACIDAD DE ELEV. NOMINAL SOBRE LADO, PALA ARRIBA – kg (lb)		
	ELEVACIÓN A MAX. RADIO, kg (lb) a mm (pulg.)			ELEVACIÓN A MAX. RADIO, kg (lb) a mm (pulg.)		
	2000 (78.7)	3000 (118.1)	4000 (157.5)	2000 (78.7)	3000 (118.1)	4000 (157.5)
3000 (118.1)	*459 (1012)	*508 (1120) @3230 (127.2)	*531 (1171) @3840 (151.2)	*478 (1054) @3230 (127.2)	*455 (1003)	350 (772) @3230 (127.2)
2000 (78.7)	*521 (1149)	*499 (1100)	328 (723) @3840 (151.2)	328 (723) @3840 (151.2)	399 (880)	262 (578) @3840 (151.2)
1000 (39.4)	*756 (1667)	*572 (1261)	296 (653) @4030 (158.7)	296 (653) @4030 (158.7)	375 (827)	237 (522) @4030 (158.7)
Suelo	*929 (2048)	*613 (1351) @3880 (152.8)	316 (697) @3880 (152.8)	316 (697) @3880 (152.8)	379 (836)	243 (536) @3880 (152.8)
-1000 (-39.4)	*1723 (3799)	*666 (1468) @3320 (130.7)	441 (972) @3320 (130.7)	441 (972) @3320 (130.7)	375 (827)	319 (703) @3320 (130.7)

ADVERTENCIA

UNA CARGA EXCESIVA PUEDE LADEAR LA EXCAVADORA Y PROVOCAR LESIONES O FATALIDADES

- No levante o sostenga una carga que supere estos límites a sus radios de carga especificados y altura.
- Se muestra la carga nominal total. Reste el peso de todos los dispositivos elevadores para determinar la carga neta que se puede levantar.

Donde corresponda, las especificaciones cumplen con las normas ISO. Las especificaciones están sujetas a cambios sin previo aviso. El punto de elevación es el punto de articulación del cucharón con un cucharón estándar instalado y con el cilindro del cucharón completamente extendido.

*Capacidad de elevación hidráulica nominal

80523 SW 7206149 esAR

EXCAVATRICE MODÈLE E26

LONGUEUR DU BALANCIER : 1 100 mm (43,3 po)
 508 mm (20,0 po)
 GODET STANDARD : 84 kg (185 lb)

X-CHANGE QUICK-TACH
 CONTREPOIDS AJOUTABLE

HAUTEUR DU POINT DE LEVAGE	CAPACITÉ DE LEVAGE EXTREMITÉ LAME, CELLE-CI ÉTANT BAISSÉE - kg (lb)			CAPACITÉ DE LEVAGE EXTREMITÉ LAME, CELLE-CI ÉTANT RELEVÉE - kg (lb)			CAPACITÉ DE LEVAGE LATÉRAL, AVEC LA LAME RELEVÉE - kg (lb)			
	RAYON DE LEVAGE - mm (po)			RAYON DE LEVAGE - mm (po)			RAYON DE LEVAGE - mm (po)			
	2 000 (78,7)	3 000 (118,1)	4 000 (157,5)	2 000 (78,7)	3 000 (118,1)	4 000 (157,5)	2 000 (78,7)	3 000 (118,1)	4 000 (157,5)	
3 000 (118,1)	*459 (1 012)	*508 (1 120)	*531 (1 171)	*440 (970)	*478 (1 054)	*455 (1 003)				350 (772) à 3 230 (127,2)
2 000 (78,7)	*521 (1 149)	*531 (1 171)	*567 (1 250)	*499 (1 100)	328 (723) à 3 840 (151,2)	399 (880)				262 (578) à 3 840 (151,2)
1 000 (39,4)	*756 (1 667)	*567 (1 250)	*613 (1 351)	488 (1 076)	296 (653) à 4 030 (158,7)	375 (827)	234 (516)			237 (522) à 4 030 (158,7)
Au niveau du sol	*1 752 (3 862)	*613 (1 351)	*666 (1 466)	486 (1 071)	316 (697) à 3 880 (152,8)	379 (836)				243 (536) à 3 880 (152,8)
-1 000 (-39,4)	*1 723 (3 799)	*808 (1 781)		506 (1 116)	441 (972) à 3 320 (130,7)	375 (827)				319 (703) à 3 320 (130,7)

AVERTISSEMENT

TOUTE SURCHARGE PEUT ENTRAÎNER LE RENVERSEMENT DE L'EXCAVATRICE ET PROVOQUER DES BLESSURES GRAVES, VOIRE MORTELLES

- Ne jamais lever ni porter de charges qui dépassent les capacités au rayon et à la hauteur spécifiés.
- Le chiffre indique représente la charge nominale totale. Le poids de tous les équipements, de levage doit être déduit pour déterminer la charge nette pouvant être soulevée.

Le cas échéant, les caractéristiques techniques sont conformes aux normes ISO. Elles peuvent être modifiées sans préavis. Le point de levage s'entend comme le point d'articulation du godet (godet standard) avec le vérin de godet en extension complète.

* Capacité de levage hydraulique nominale

80623 SW 7206149 IFC

Lift Chart (7206150) With Long Arm and Additional Counterweight

EXCAVATOR MODEL E26

ARM LENGTH: 1400 mm (55.1 in)
 STANDARD BUCKET: 508 mm (20.0 in)
 X-CHANGE QUICK-TACH
 ADD-ON COUNTERWEIGHT

Lift Point Height Lift Radius

LIFT POINT HEIGHT	RATED LIFT CAPACITY OVER BLADE, BLADE DOWN - kg (lb)			RATED LIFT CAPACITY OVER BLADE, BLADE UP - kg (lb)			RATED LIFT CAPACITY OVER SIDE, BLADE UP - kg (lb)		
	LIFT RADIUS - mm (in)			LIFT RADIUS - mm (in)			LIFT RADIUS - mm (in)		
	2000 (78.7)	3000 (118.1)	4000 (157.5)	2000 (78.7)	3000 (118.1)	4000 (157.5)	2000 (78.7)	3000 (118.1)	4000 (157.5)
3000 (118.1)	*436 (961) @3570 (140.6)	*458 (1010) @4120 (162.2)	*495 (1091) @4300 (169.3)	*415 (915) @3570 (140.6)	*470 (1036) @4120 (162.2)	225 (496) @4120 (162.2)	300 (661) @3570 (140.6)	225 (496) @4120 (162.2)	300 (661) @3570 (140.6)
2000 (78.7)	*421 (928) @3570 (140.6)	*444 (979) @4120 (162.2)	*495 (1091) @4300 (169.3)	281 (619) @4120 (162.2)	*470 (1036) @4120 (162.2)	242 (534) @4120 (162.2)	225 (496) @4120 (162.2)	242 (534) @4120 (162.2)	225 (496) @4120 (162.2)
1000 (39.4)	*679 (1497) @3570 (140.6)	*512 (1129) @4120 (162.2)	*495 (1091) @4300 (169.3)	259 (571) @4300 (169.3)	384 (847) @4300 (169.3)	233 (514) @4300 (169.3)	200 (441) @4300 (169.3)	233 (514) @4300 (169.3)	200 (441) @4300 (169.3)
Ground	*1671 (3684) @3570 (140.6)	*576 (1270) @4120 (162.2)	*539 (1188) @4190 (165)	275 (606) @4190 (165)	362 (798) @4190 (165)	226 (498) @4190 (165)	209 (461) @4190 (165)	226 (498) @4190 (165)	209 (461) @4190 (165)
-1000 (-39.4)	*1624 (3580) @3570 (140.6)	*865 (1907) @4120 (162.2)	*598 (1318) @3670 (144.5)	350 (772) @3670 (144.5)	363 (800) @3670 (144.5)	712 (1570) @3670 (144.5)	281 (575) @3670 (144.5)	363 (800) @3670 (144.5)	281 (575) @3670 (144.5)
-2000 (-78.7)	*1211 (2670) @3570 (140.6)		*612 (1349) @2600 (102.4)	*653 (1440) @2600 (102.4)		965 (2127) @2600 (102.4)	488 (1076) @2600 (102.4)	965 (2127) @2600 (102.4)	488 (1076) @2600 (102.4)

* Rated Hydraulic Lift Capacity

WARNING

OVERLOAD CAN TIP THE EXCAVATOR AND CAUSE INJURY OR DEATH

- Do not lift or hold any load that exceeds these ratings at their specified load radii and height.
- Total rated load is shown. The weight of all lifting devices must be deducted to determine the net load that can be lifted.

Where applicable, specifications conform to ISO Standards. Specifications are subject to change without notice. Lift point is bucket hinge point with standard bucket attached and bucket cylinder fully extended.

80623 SW 7206150 enUS

EXCAVADORA MODELO E26

(55.1 pulgadas)
(20.0 pulgadas)
(185 lb)
84 kg

SISTEMA X-CHANGE CON ENGANCHE RÁPIDO
CON CONTRAPESOS

LARGO DE BRAZO
1400 mm
CUCCHARÓN ESTÁNDAR
508 mm

Altura del punto de elevación

Radio de elevación

ALTURA DEL PUNTO DE ELEVACIÓN mm (pulg.)	CAPACIDAD DE ELEV. NOMINAL SOBRE PALA, PALA ABAJO - kg (lb)			CAPACIDAD DE ELEV. NOMINAL SOBRE LADO, PALA ARRIBA - kg (lb)		
	ELEVACIÓN A			ELEVACIÓN A		
	2000 (78.7)	3000 (118.1)	4000 (157.5)	2000 (78.7)	3000 (118.1)	4000 (157.5)
3000 (118.1)				*415 (915) @3570 (140.6)		
2000 (78.7)	*421 (928)	*444 (979)	*402 (886)	*281 (619) @4120 (162.2)	*470 (1036)	242 (534)
1000 (39.4)	*679 (1497)	*512 (1129)	490 (1080)	259 (571) @4300 (169.3)	384 (847)	233 (514)
Suelo	*1671 (3684)	*860 (1896)	944 (2081)	275 (606) @4190 (165)	693 (1528)	226 (498)
-1000 (-39.4)	*1624 (3580)	*865 (1907)	1089 (2401)	350 (772) @3670 (144.5)	712 (1570)	363 (800)
-2000 (-78.7)	*1211 (2670)		927 (2044)	*653 (1440) @2600 (102.4)	965 (2127)	

*Capacidad de elevación hidráulica nominal

ADVERTENCIA

UNA CARGA EXCESIVA PUEDE LADEAR LA EXCAVADORA Y PROVOCAR LESIONES O FATALIDADES

- No levante o sostenga una carga que supere estos límites a sus radios de carga especificados y altura.
- Se muestra la carga nominal total. Reste el peso de todos los dispositivos elevadores para determinar la carga neta que se puede levantar.

Donde corresponda, las especificaciones cumplen con las normas ISO.

Las especificaciones están sujetas a cambios sin previo aviso. El punto de elevación es el punto de articulación del cucharón con un cucharón estándar instalado y con el cilindro del cucharón completamente extendido.

80623 SW
7206150 esAR

EXCAVATRICE MODÈLE E26

LONGUEUR DU BALANCIER : 1 400 mm (55,1 po)
 GODET STANDARD : 508 mm (20,0 po)
 84 kg (185 lb)

X-CHANGE QUICK-TACH
 CONTREPOIDS AJOUTABLE

*Hauteur du point de levage

Rayon de levage

HAUTEUR DU POINT DE LEVAGE	CAPACITÉ DE LEVAGE EXTRÊMITÉ LAME, CELLE-CI ÉTANT BAISSÉE - kg (lb)			CAPACITÉ DE LEVAGE EXTRÊMITÉ LAME, CELLE-CI ÉTANT RELEVÉE - kg (lb)			CAPACITÉ DE LEVAGE LATÉRAL, AVEC LA LAME RELEVÉE - kg (lb)			
	RAYON DE LEVAGE - mm (po)			RAYON DE LEVAGE - mm (po)			RAYON DE LEVAGE - mm (po)			
	2 000 (78,7)	3 000 (118,1)	4 000 (157,5)	2 000 (78,7)	3 000 (118,1)	4 000 (157,5)	2 000 (78,7)	3 000 (118,1)	4 000 (157,5)	
3 000 (118,1)	*436 (961) à 3 570 (140,6)			*415 (915) à 3 570 (140,6)						300 (661) à 3 570 (140,6)
2 000 (78,7)	*421 (928)	*444 (979)		*402 (886)	311 (686)		*470 (1 036)	242 (534)		225 (496) à 4 120 (162,2)
1 000 (39,4)	*679 (1 497)	*512 (1 129)		490 (1 080)	296 (653)		384 (847)	233 (514)		200 (441) à 4 300 (169,3)
Au niveau du sol	*1671 (3 684)	*860 (1 896)		478 (1 054)	295 (650)		362 (798)	226 (498)		209 (461) à 4 190 (165)
-1 000 (-39,4)	*1 624 (3 580)	*865 (1 907)		472 (1 041)			363 (800)			281 (575) à 3 670 (144,5)
-2 000 (-78,7)	*1 211 (2 670)						965 (2 127)			488 (1 076) à 2 600 (102,4)

AVERTISSEMENT

TOUTE SURCHARGE PEUT ENTRAINER LE RENVERSEMENT DE L'EXCAVATRICE ET PROVOQUER DES BLESSURES GRAVES, VOIRE MORTELLES

- Ne jamais lever ni porter de charges qui dépassent les capacités au rayon et à la hauteur spécifiés.
- Le chiffre indiqué représente la charge nominale totale. Le poids de tous les équipements de levage doit être ajouté pour déterminer la charge nette pouvant être soulevée.

Le cas échéant, les caractéristiques techniques sont conformes aux normes ISO. Elles peuvent être modifiées sans préavis. Le point de levage s'entend comme le point d'articulation du godet (godet standard) avec le bras de godet en extension complète.

* Capacité de levage hydraulique nominale

80623 SW 7206150 r/CA

Warning (7148157)

⚠ WARNING	
AVOID INJURY OR DEATH	
	
Fasten seat belt securely. Keep feet and hands on controls. Operate controls only from operator's position.	Never use Excavator without instructions. Read Operation & Maintenance Manual and Handbook.
	
Keep away from drop-offs. Avoid steep areas or banks that could break away.	Always use cab/canopy. Never modify equipment or use attachments not approved by Bobcat Company.
	
Keep bystanders away. No riders. Check location of blade for direction of travel before moving steering controls.	Check for overhead or underground lines before operating.
	
On slopes, keep heavy end uphill. Do not travel or turn with attachment extended.	When swinging loads: • Keep load low. • Swing slowly. • Do not exceed lift capacity. Read lift capacity chart.
TO LEAVE THE EXCAVATOR:	
1 	2 
Lower attachment. Never park with tracks pointed down hill.	Stop the engine. Raise control console.
Weitere instruktionen finden sie in der Bedienungsanleitung. Consulte el Manual del Operador par mas instrucciones. Se reporter au manual de l'opérateur pour plus de renseignements.	
75155 SW	7148157A enUS

⚠ ADVERTENCIA	
EVITE LESIONES O LA MUERTE	
	
Ajustese el cinturón de seguridad. Mantenga los pies y las manos en los controles. Haga funcionar los controles sólo desde la posición del operador.	Nunca utilice la excavadora sin leer las instrucciones. Lea el Manual de funcionamiento y mantenimiento.
	
Manténgase alejado de las bajadas. Evite las áreas pronunciadas o terrenos que puedan romperse.	Use siempre la cabina/cubierta. Nunca modifique el equipo o utilice accesorios que no estén aprobados por Bobcat Company.
	
Mantenga a los transeúntes alejados. No debe haber ocupantes. Controle la ubicación de la hoja para la dirección de desplazamiento antes de mover los controles de dirección.	Controle que no haya líneas aéreas o subterráneas antes de comenzar la operación.
	
En las rampas, mantenga el extremo con la carga cuesta arriba. No se desplace ni gire con el accesorio extendido.	Al girar cargas: • Mantenga la carga baja. • Gírela lentamente. • No exceda la capacidad de elevación. Lea la tabla de capacidad de elevación.
PARA RETIRARSE DE LA EXCAVADORA:	
1 	2 
Baje el accesorio. Nunca estacione con las bandas de rodamiento en una pendiente.	Detenga el motor. Eleve la consola de control.
Weitere instruktionen finden sie in der Bedienungsanleitung. Consulte el Manual del Operador par mas instrucciones. Se reporter au manual de l'opérateur pour plus de renseignements.	
75155 SW	7148157A esAG







Dealer Copy -- Not for Resale



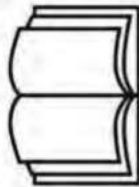



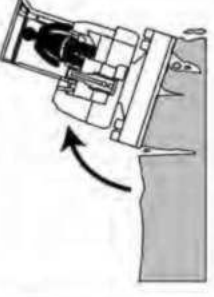
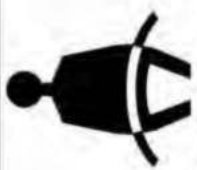



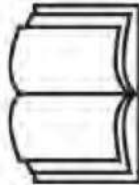

MACHINE SIGN TRANSLATIONS (CONT'D)

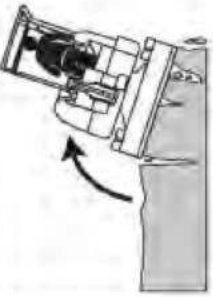
Warning (7148157) (Cont'd)

⚠️ AVERTISSEMENT	
RISQUE DE BLESSURE OU DE MORT	
	
<p>Attachez bien votre ceinture de sécurité. Gardez les pieds et les mains sur les commandes. Utilisez les commandes uniquement depuis la position de l'opérateur.</p>	<p>N'utilisez jamais l'excavatrice sans consulter les instructions. Lisez le guide et le manuel d'utilisation et d'entretien.</p>
	
<p>Restez à l'écart des précipices. Évitez les pentes raides ou les surfaces friables.</p>	<p>Utilisez toujours la cabine/le cadre de protection. Ne modifiez jamais l'équipement et n'utilisez jamais d'accessoires qui ne sont pas approuvés par Bobcat Company.</p>
	
<p>Gardez les spectateurs à distance. Ne transportez personne. Vérifiez l'emplacement de la lame pour établir le sens de la marche avant de manipuler les commandes de direction.</p>	<p>Vérifiez s'il existe des lignes aériennes ou souterraines avant tout travail.</p>
	
<p>Sur les pentes, gardez le côté lourd vers le haut. Ne virez pas et ne déplacez pas la machine quand l'accessoire est déployé.</p>	<p>Lors de l'oscillation avec une charge :</p> <ul style="list-style-type: none"> • Gardez la charge près du sol. • Oscillez lentement. • Ne dépassez pas la capacité de levage. Lisez le tableau des capacités de levage.
POUR QUITTER L'EXCAVATRICE :	
<p>1</p> 	<p>2</p> 
<p>Abaissez l'accessoire. Ne la stationnez pas avec ses chenilles dirigées dans le sens d'une descente.</p>	<p>Arrêtez le moteur. Relevez la console des commandes.</p>
<p>Weitere Instruktionen finden sie in der Bedienungsanleitung. Consulte el Manual del Operador por mas instrucciones. Se reporter au manuel de l'opérateur pour plus de renseignements.</p>	
75155 SW	7148157A frCA

Dealer Copy -- Not for Resale

<h1>⚠ WARNING</h1> <h2>AVOID INJURY OR DEATH</h2>	
	<p>Never use Excavator without instructions. Read Operation and Maintenance Manual and Handbook.</p>
	<p>Always use cab/canopy. Never modify equipment or use attachments not approved by Bobcat Company.</p>
	<p>Check for overhead or underground lines before operating.</p>
	<p>On slopes, keep heavy end uphill. Do not travel or turn with attachment extended.</p>
	<p>When swinging loads: ● Keep load low. ● Swing slowly. ● Do not exceed lift capacity. Read lift capacity chart.</p>
	<p>Keep bystanders away. No riders. Check location of blade for direction of travel before moving steering controls.</p>
	<p>Keep away from drop-offs. Avoid steep areas or banks that could break away.</p>
	<p>Fasten seat belt securely. Keep feet and hands on controls. Operate controls only from operator's position.</p>
<p>1</p> 	<p>TO LEAVE THE EXCAVATOR: Lower attachment. Never park with tracks pointed down hill.</p>
<p>2</p> 	<p>Stop the engine. Raise control console.</p>
<p>Weitere Instruktionen finden sie in der Bedienungsanleitung. Consulte el Manual del Operador por mas instrucciones. Se reporter au manual de l'opérateur pour plus de renseignements.</p>	
<p>75155 SW 7178177 enUS</p> 	

<h1 style="margin: 0;">⚠ ADVERTENCIA</h1> <h2 style="margin: 0;">EVITE LESIONES O LA MUERTE</h2>					
	<p>Nunca utilice la excavadora sin leer las instrucciones.</p> <p>Lea el Manual de funcionamiento y mantenimiento.</p>		<p>Use siempre la cabina/cubierta.</p> <p>Nunca modifique el equipo o utilice accesorios que no estén aprobados por Bobcat Company.</p>		<p>Controle que no haya líneas aéreas o subterráneas antes de comenzar la operación.</p>
	<p>Ajustese el cinturón de seguridad. Mantenga los pies y las manos en los controles.</p> <p>Haga funcionar los controles sólo desde la posición del operador.</p>		<p>Manténgase alejado de las bajadas. Evite las áreas pronunciadas o terraplenes que puedan romperse.</p>		<p>Mantenga a los transeúntes alejados. No debe haber ocupantes. Controle la ubicación de la hoja antes de mover los controles de dirección.</p>
	<p>En las rampas, mantenga el extremo con la carga cuesta arriba.</p> <p>No se desplace ni gire con el accesorio extendido.</p>		<p>Al girar cargas:</p> <ul style="list-style-type: none"> ● Mantenga la carga baja. ● Gírela lentamente. ● No exceda la capacidad de elevación. <p>Lea la tabla de capacidad de elevación.</p>		<p>Se reporter au manual de l'opérateur pour plus de renseignements.</p>
	<p>1</p> <p>PARA RETIRARSE DE LA EXCAVADORA:</p> <p>Baja el accesorio.</p> <p>Nunca estacione con las bandas de rodamiento en una pendiente.</p>		<p>2</p> <p>Detenga el motor.</p> <p>Eleve la consola de control.</p>		<p>Weitere Instruktionen finden sie in der Bedienungsanleitung. Consulte el Manual del Operador para obtener más instrucciones.</p>

75195 SW 7178177 esAR

AVERTISSEMENT				
RISQUE DE BLESSURE OU DE MORT				
	N'utilisez jamais l'excavatrice sans consulter les instructions. Lisez le guide et le manuel d'utilisation et d'entretien.		Utilisez toujours la cabine/le cadre de protection. Ne modifiez jamais l'équipement et n'utilisez jamais d'accessoires qui ne sont pas approuvés par Bobcat Company.	
	Attachez bien votre ceinture de sécurité. Gardez les pieds et les mains sur les commandes. Utilisez les commandes uniquement depuis la position de l'opérateur.		Sur les pentes, gardez le côté lourd vers le haut. Ne virez pas et ne déplacez pas la machine quand l'accessoire est déployé.	
	1 Abaissez l'accessoire. Ne la stationnez pas avec ses chenilles dirigées dans le sens d'une descente.		2 Arrêtez le moteur. Relevez la console des commandes.	
		<p>AVANT DE QUITTER L'EXCAVATRICE :</p> <p>1</p> <p>Abaissez l'accessoire. Ne la stationnez pas avec ses chenilles dirigées dans le sens d'une descente.</p> <p>2</p> <p>Arrêtez le moteur. Relevez la console des commandes.</p>		<p>Weitere Instruktionen finden sie in der Bedienungsanleitung.</p> <p>Consulte el Manual del Operador par mas instrucciones.</p> <p>Consultez le manuel d'utilisation pour plus de renseignements.</p>
		<p>Lors de l'oscillation avec une charge :</p> <ul style="list-style-type: none"> ● Gardez celle-ci le plus bas possible. ● Oscillez lentement. ● Ne dépassez pas la capacité de levage. <p>Lisez le tableau des capacités de levage.</p>		<p>75155 SW</p> <p>7178177 rCA</p>

MACHINE SIGN TRANSLATIONS (CONT'D)

Warning (6708929)

DO NOT Add Ethylene Glycol Coolant
 COOLANT SYSTEM PROTECTED
 TO -34°F (-37°C) WITH
 BOBCAT® PG COOLANT
 (Propylene Glycol)
 Check Condition With Refractometer
 See Operation and Maintenance Manual
 65351 SW 6708929C enUS

NO AÑADA fluido refrigerante etilenglicol
 EL SISTEMA DE ENFRIAMIENTO ESTÁ PROTEGIDO
 HASTA -34°F (-37°C) CON
 REFRIGERANTE BOBCAT PG
 (propilenglicol)
 Verifique las condiciones del sistema con el refractómetro.
 Consulte el Manual de operación y mantenimiento.
 39933 SW 01 6708929 AR

N'ajoutez PAS d'éthylèneglycol
 SYSTÈME DE REFROIDISSEMENT PROTÉGÉ
 JUSQU'À -37 °C (-34 °F) AVEC
 LE LIQUIDE DE REFROIDISSEMENT BOBCAT®
 (au propylèneglycol)
 Vérifiez son état avec un réfractomètre
 Consultez le manuel d'utilisation et d'entretien
 65351 SW 6708929C frCA

Warning (6809832)

<p>WARNING</p>  <p>Rotating fan blade can cause serious injury. Do not operate with guard removed.</p>	<p>AVERTISSEMENT</p>  <p>Risque de blessures graves. Ne touchez pas les pales du ventilateur en mouvement. Laissez les protections en place.</p>	<p>ADVERTENCIA</p>  <p>Rotar la cuchilla del ventilador puede causar lesiones serias. No opere la máquina sin el protector colocado.</p>
<p>WARNING</p>  <p>Hot surfaces can cause serious injury. Do not touch. Allow to cool before servicing.</p>	<p>AVERTISSEMENT</p>  <p>Risque de blessures graves. Ne touchez pas les surfaces brûlantes. Laissez refroidir avant toute intervention</p>	<p>ADVERTENCIA</p>  <p>Las superficies calientes pueden causar lesiones serias. No las toque. Permita que se enfrien antes de realizar un mantenimiento.</p>

Warning (6804233)

WARNING

- Hot pressurized fluid.
- Can cause serious burns.

39894 SW 98 6804233

ADVERTENCIA

- Fluido presurizado caliente.
- Puede provocar quemaduras graves.

39894 SW 01 6804233 AR

AVERTISSEMENT

- Fluide chaud sous pression.
- Peut gravement brûler.

39894 SW 6804233 frCA

Dealer Copy -- Not for Resale

MACHINE SIGN TRANSLATIONS (CONT'D)

Warning (7148145)

⚠ WARNING

AVOID INJURY OR DEATH

- Know the control pattern before operating.
- See Operation and Maintenance Manual or Handbook for more information.

	A STD	B ISO

74319 SW 7148145A enUS

⚠ ADVERTENCIA

EVITE LESIONES O LA MUERTE

- Familiarícese con el patrón de control antes de comenzar la operación.
- Para obtener más información, consulte el Manual de funcionamiento y mantenimiento.

	A STD	B ISO

74319 SW 7148145A esAR

⚠ AVERTISSEMENT

RISQUE DE BLESSURE OU DE MORT

- Il faut connaître le schéma de commande avant d'utiliser la machine.
- Consultez le guide ou le manuel d'utilisation et d'entretien pour obtenir plus d'informations.

	A STD	B ISO

74319 SW 7148145A frCA

Warning (7148147)

⚠ WARNING

AVOID INJURY OR DEATH

- Know the control pattern before operating.
- See Operation and Maintenance Manual or Handbook.

A STD	B ISO

AUX HYD

--	--

74319 SW 7148147A enUS

⚠ ADVERTENCIA

EVITE LESIONES O LA MUERTE

- Familiarícese con el patrón de control antes de comenzar la operación.
- Consulte el Manual de funcionamiento y mantenimiento.

A STD	B ISO

HIDR AUX

--	--

74319 SW 7148147A esAR

⚠ AVERTISSEMENT

RISQUE DE BLESSURE OU DE MORT

- Il faut connaître le schéma de commande avant d'utiliser la machine.
- Consultez le guide ou le manuel d'utilisation et d'entretien.

A STD	B ISO

AUX. HYDR.

--	--

74319 SW 7148147A frCA

Dealer Copy -- Not for Resale

Using the Pin-On X-Change (6818059)

USING THE PIN ON X-CHANGE® SYSTEM	
<p>ATTACHMENT REMOVAL</p> <ol style="list-style-type: none"> 1. Position ARM VERTICAL, lower attachment to ground and stop engine. 2. Turn key to ON position (not start) and move both joysticks to relieve hydraulic pressure. 3. Remove retainer pin. 4. Remove pin. 5. Start engine. Lift boom to disengage attachment. 6. Fully retract bucket cylinder. 7. Lower boom until pins disengage from hooks. 8. Move arm toward operator. 	
<p>ATTACHMENT INSTALLATION</p> <ol style="list-style-type: none"> 1. Fully retract bucket cylinder. 2. Engage pins into hooks. 3. Lift boom and extend bucket cylinder until X-Change contacts attachment back. 4. Lower boom and attachment to ground WITH ARM VERTICAL until X-Change is fully engaged. 5. Stop engine, turn key to ON position (not start) and move both joysticks to relieve hydraulic pressure. 6. Install pin. 7. Install retainer pin. 8. Check for proper installation. Lift attachment and fully extend and retract bucket cylinder. 	
<p>See Operation and Maintenance Manual and Handbook for more instructions and use with other attachments.</p>	
<p>76191 SW 6818059C enUS</p>	

Dealer Copy -- Not for Resale

MODO DE USAR EL SISTEMA X-CHANGE[®] COLOCADO CON PASADORES

DESINSTALACIÓN DEL IMPLEMENTO	
<ol style="list-style-type: none"> 1. Coloque en BRAZO en posición VERTICAL, descienda el implemento hasta el suelo y detenga el motor. 2. Gire la llave a la posición ON (no encienda el motor) y mueva ambos joysticks para liberar la presión hidráulica. 3. Retire el pasador retenedor. 4. Retire el pasador. 5. Encienda el motor. Eleve el boom/pluma y libere el implemento. 6. Retraiga del todo el cilindro del cucharón. 7. Descienda el boom/pluma hasta que los pasadores se liberen de los ganchos. 8. Mueva el brazo hacia usted. 	
<ol style="list-style-type: none"> 1. Retraiga del todo el cilindro del cucharón. 2. Coloque los pasadores dentro de los ganchos. 3. Eleve el boom/pluma y extienda el cilindro del cucharón hasta que el X-Change haga contacto con el espaldar del implemento. 4. Descienda el boom/pluma e implemento hasta el suelo CON EL BRAZO EN POSICIÓN VERTICAL hasta que el X-Change quede totalmente enganchado. 5. Detenga el motor, gire la llave a la posición ON (no encienda el motor) y mueva ambos joysticks para liberar la presión hidráulica. 6. Instale el pasador. 7. Instale el pasador retenedor. 8. Revise que la instalación haya quedado correcta. Eleve el implemento y extienda y retraiga del todo el cilindro del cucharón. 	
<ol style="list-style-type: none"> 1. Retraiga del todo el cilindro del cucharón. 2. Coloque los pasadores dentro de los ganchos. 3. Eleve el boom/pluma y extienda el cilindro del cucharón hasta que el X-Change haga contacto con el espaldar del implemento. 4. Descienda el boom/pluma e implemento hasta el suelo CON EL BRAZO EN POSICIÓN VERTICAL hasta que el X-Change quede totalmente enganchado. 5. Detenga el motor, gire la llave a la posición ON (no encienda el motor) y mueva ambos joysticks para liberar la presión hidráulica. 6. Instale el pasador. 7. Instale el pasador retenedor. 8. Revise que la instalación haya quedado correcta. Eleve el implemento y extienda y retraiga del todo el cilindro del cucharón. 	

Consulte el Manual de Operación y Mantenimiento y el Manual del Operador para más instrucciones y uso con otros implementos.

76191 SW 5818059C #5AR

UTILISATION DU SYSTEME X-CHANGE™ AVEC AXE	
<p>DÉPOSE DE L'ACCESSOIRE</p> <ol style="list-style-type: none"> 1. Placez le BRAS EN POSITION VERTICALE, abaissez l'accessoire sur le sol et arrêtez le moteur. 2. Tournez la clé en position ON (Marche) (pas en position Start (Démarrage)) et déplacez les deux manipulateurs pour libérer la pression hydraulique. 3. Déposez la goupille de retenue. 4. Déposez l'axe. 5. Démarrez le moteur, Relevez la flèche pour détacher l'accessoire. 6. Rétractez complètement le vérin du godet. 7. Abaissez la flèche jusqu'à ce que les axes se désengagent des crochets. 8. Déplacez le bras vers l'opérateur. 	
<p>INSTALLATION DE L'ACCESSOIRE</p> <ol style="list-style-type: none"> 1. Rétractez complètement le vérin du godet. 2. Engagez les axes dans les crochets. 3. Relevez la flèche et étendez le vérin du godet jusqu'à ce que le X-Change entre en contact avec l'arrière de l'accessoire. 4. Abaissez la flèche et l'accessoire sur le sol AVEC LE BRAS VERTICAL jusqu'à ce que le X-Change s'engage complètement. 5. Arrêtez le moteur, tournez la clé en position ON (Marche) (pas en position Start (Démarrage)) et déplacez les deux manipulateurs pour libérer la pression hydraulique. 6. Installez l'axe. 7. Installez la goupille de retenue. 8. Vérifiez que le montage est correct. Lavez l'accessoire puis déployez et rétractez complètement le vérin du godet. 	
<p>Consultez le manuel d'utilisation et d'entretien et le guide de l'utilisateur pour plus d'instructions et pour toute utilisation avec d'autres accessoires.</p>	
<p>76191 SW 6818059C trCA</p>	

MACHINE SIGN TRANSLATIONS (CONT'D)

Joystick Control Pattern Selector Lever (7178179)

JOYSTICK CONTROL PATTERN SELECTOR

- READ AND UNDERSTAND CONTROL PATTERN BEFORE SELECTING LEVER POSITION
- ROTATE LEVER FULLY TO SELECT PATTERN

<p>CONTROL PATTERN A (STD)</p> <p>LH RH</p>	<p>CONTROL PATTERN B (ISO)</p> <p>LH RH</p>
<p>76191 SW 7178179A enUS</p>	

PALANCA DE SELECCIÓN DEL PATRÓN DE CONTROL

- LEA Y COMPRENDA EL PATRÓN DE CONTROL ANTES DE SELECCIONAR LA POSICIÓN DE LA PALANCA
- ROTE POR COMPLETO LA PALANCA PARA SELECCIONAR EL PATRÓN

<p>PATRÓN DE CONTROL A (ESTD)</p> <p>MI MD</p>	<p>PATRÓN DE CONTROL B (ISO)</p> <p>MI MD</p>
<p>76191 SW 7178179A esAR</p>	

SÉLECTEUR DU SCHÉMA DE COMMANDE DU MANIPULATEUR

- LISEZ ET COMPRENEZ LE SCHÉMA DE COMMANDE AVANT DE SÉLECTIONNER LA POSITION DU LEVIER
- TOURNEZ LE LEVIER À FOND POUR SÉLECTIONNER LE SCHÉMA

<p>SCHÉMA DE COMMANDE A (STD)</p> <p>GAUCHE DROITE</p>	<p>SCHÉMA DE COMMANDE B (ISO)</p> <p>GAUCHE DROITE</p>
<p>76191 SW 7178179A frCA</p>	

Dealer Copy -- Not for Resale

MACHINE SIGN TRANSLATIONS (CONT'D)

Warning (6737189)

⚠ WARNING

THIS VEHICLE IS EQUIPPED WITH A BACK-UP ALARM.

ALARM MUST SOUND!

WHEN OPERATING THIS VEHICLE IN REVERSE.

FAILURE TO MAINTAIN A CLEAR VIEW IN THE DIRECTION OF TRAVEL COULD RESULT IN SERIOUS INJURY OR DEATH.

THE OPERATOR IS RESPONSIBLE FOR THE SAFE OPERATION OF THIS VEHICLE.

71848 SW 6737189B enUS

⚠ ADVERTENCIA

ESTE VEHÍCULO ESTÁ EQUIPADO CON UNA ALARMA DE ALERTA DE RETROCESO

¡LA ALARMA DEBE SONAR!
CUANDO RETROCEDA ESTE VEHÍCULO.

NO MANTENER UNA VISTA CLARA EN LA DIRECCIÓN DONDE VIAJA PUEDE RESULTAR EN LESIONES GRAVES O FATALIDADES.

EL OPÉRADOR ES RESPONSABLE DE LA OPERACIÓN SEGURA DE ESTE VEHÍCULO.

71848 SW 6737189B ar

⚠ ADVERTISSEMENT

CE VÉHICULE EST ÉQUIPÉ D'UNE ALARME DE REcul.

L'ALARME DOIT FONCTIONNER !
LORSQUE VOUS UTILISEZ CE VÉHICULE EN MARCHÉ ARRIÈRE.

NE PAS AVOIR UNE VUE DÉGAGÉE DANS LE SENS DE LA MARCHÉ PEUT ENTRAÎNER DES BLESSURES GRAVES, VOIRE MORTELLES.

L'OPÉRATEUR EST RESPONSABLE DE LA SÉCURITÉ LORS DE L'UTILISATION DE CE VÉHICULE.

71848 SW 6737189B fr

Warning (7169006)

⚠ WARNING

AVOID INJURY OR DEATH

Keep out of swing area and travel path.

73922 SW 7169006 enUS

⚠ ADVERTENCIA

EVITE LESIONES O LA MUERTE

Manténgase alejado del área de giro y recorrido.

73922 SW 7169006 esAR

⚠ AVERTISSEMENT

RISQUE DE BLESSURE OU DE MORT

Restez éloigné de la zone d'oscillation et de la voie de circulation.

73922 SW 7169006 frCA

Dealer Copy -- Not for Resale



Bobcat®

Dealer Copy -- Not for Resale

SPECIFICATIONS

(E26) EXCAVATOR SPECIFICATIONS	167
Machine Dimensions (Standard Arm)	167
Machine Dimensions (Long Arm)	169
Performance	171
Controls	171
Engine (E26 S/N B33211001 & Above)	172
Engine (E26 S/N AJRY11001 & Above)	172
Hydraulic System	173
Hydraulic Cylinders	174
Hydraulic Cycle Times	174
Electrical	174
Drive System	174
Slew System	175
Undercarriage	175
Capacities	175
Tracks	175
Ground Pressure	175

Dealer Copy -- Not for Resale



Bobcat®

Dealer Copy -- Not for Resale

(E26) EXCAVATOR SPECIFICATIONS

Machine Dimensions (Standard Arm)

- Where applicable, specification conform to SAE or ISO standards and are subject to change without notice.

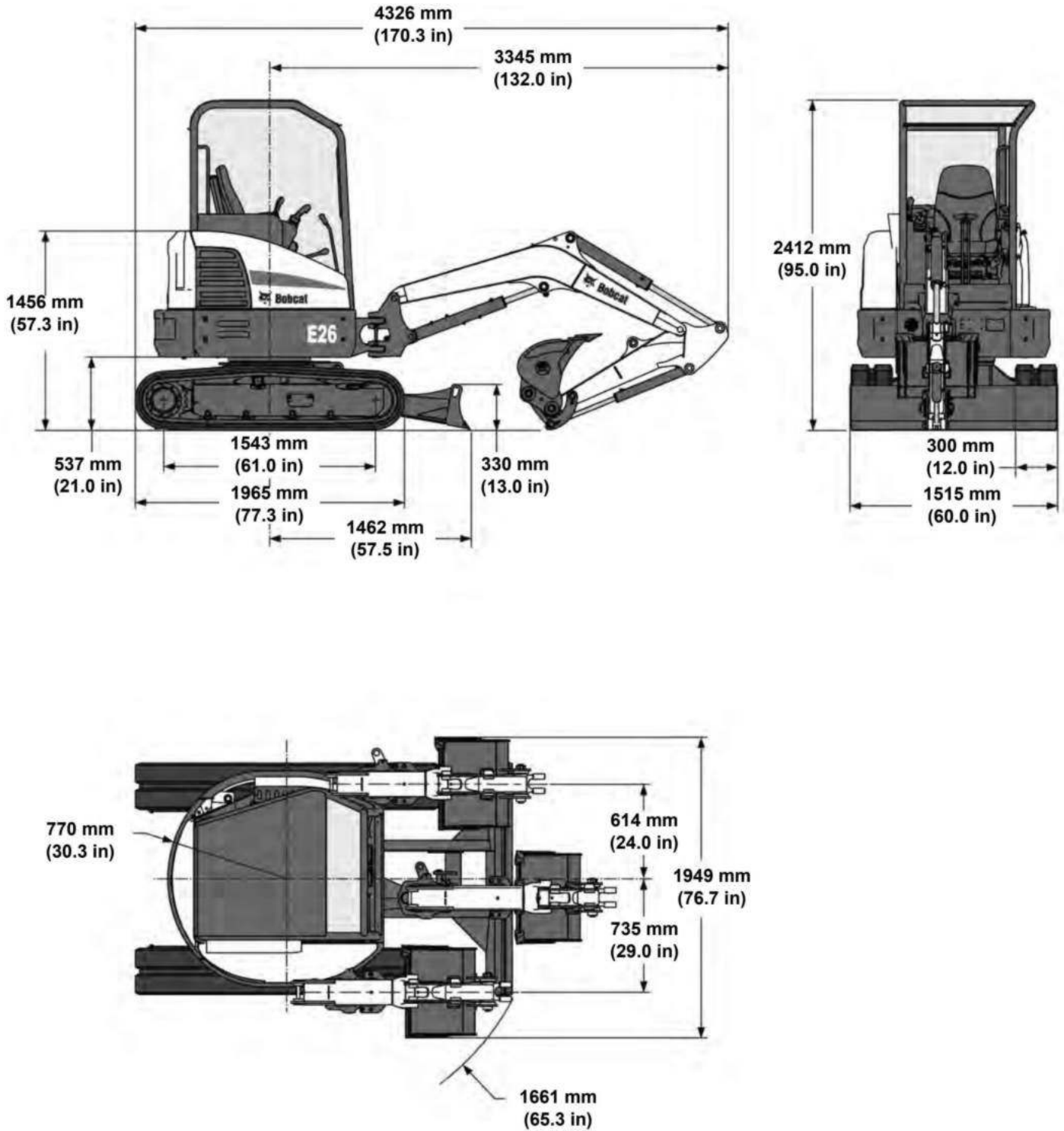

Dealer Copy -- Not for Resale

EM7543

(E26) EXCAVATOR SPECIFICATIONS (CONT'D)

Machine Dimensions (Standard Arm) (Cont'd)

- Where applicable, specification conform to SAE or ISO standards and are subject to change without notice.

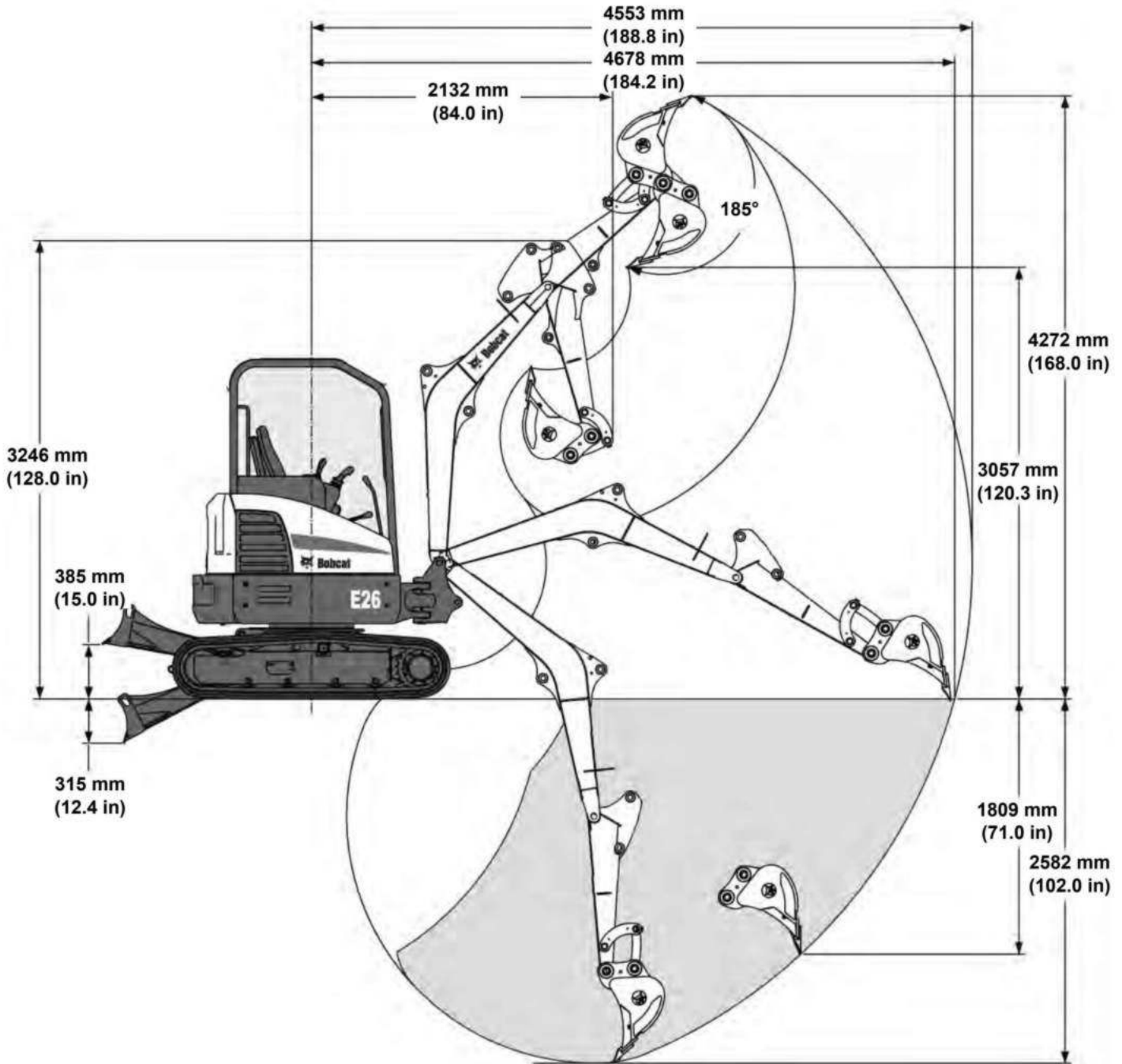

Dealer Copy -- Not for Resale

EM7545

(E26) EXCAVATOR SPECIFICATIONS (CONT'D)

Machine Dimensions (Long Arm)

- Where applicable, specification conform to SAE or ISO standards and are subject to change without notice.

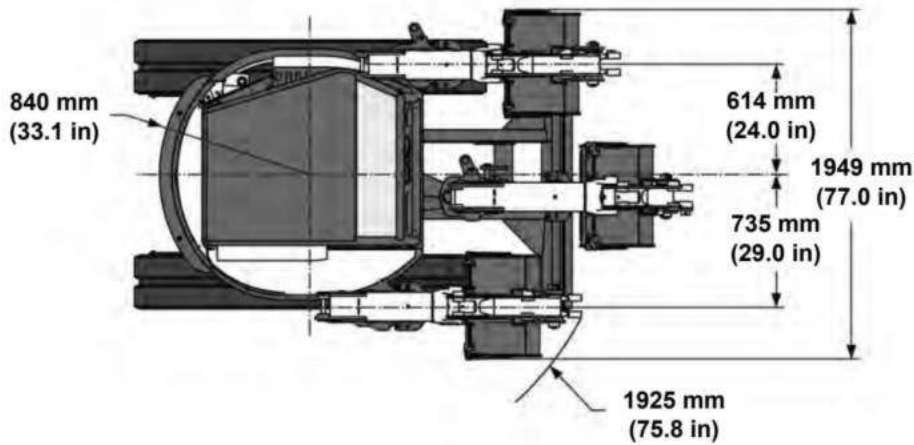
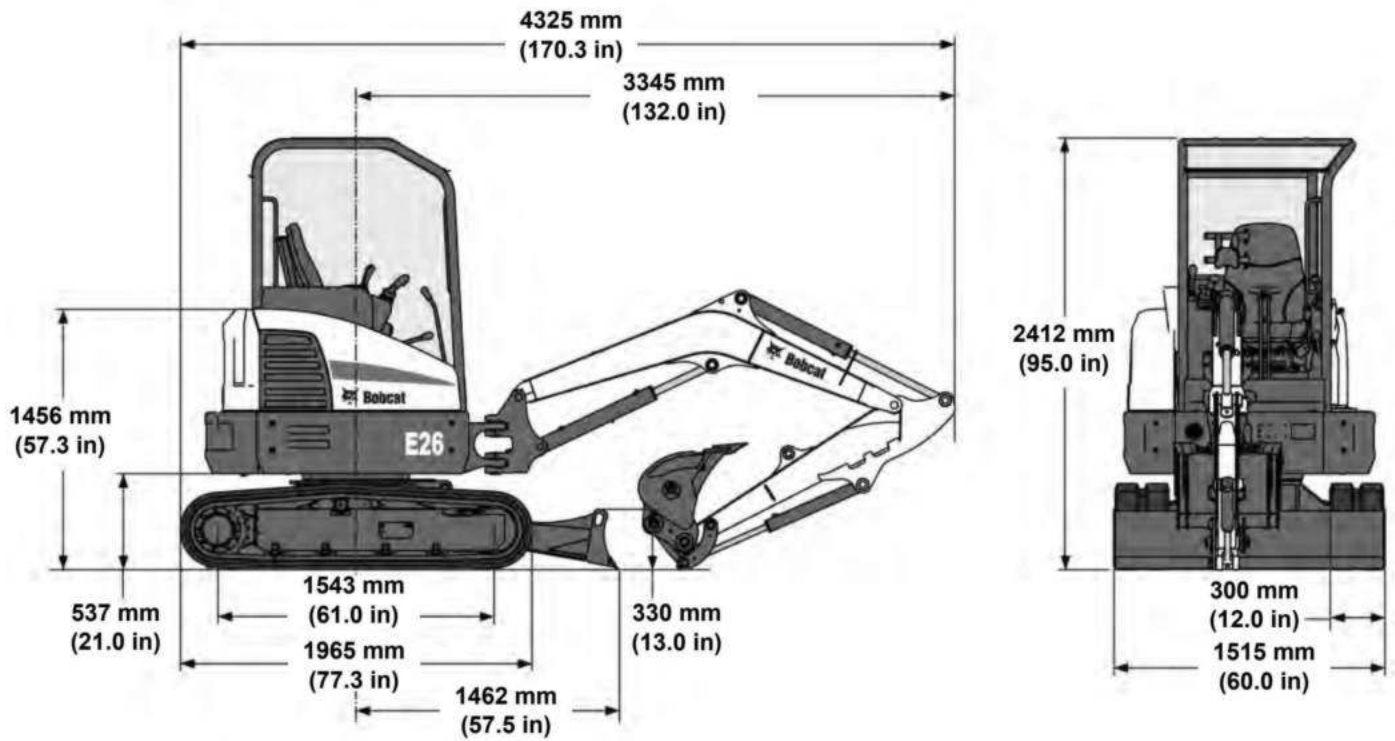

Dealer Copy -- Not for Resale

EM7546

(E26) EXCAVATOR SPECIFICATIONS (CONT'D)

Machine Dimensions (Long Arm) (Cont'd)

- Where applicable, specification conform to SAE or ISO standards and are subject to change without notice.

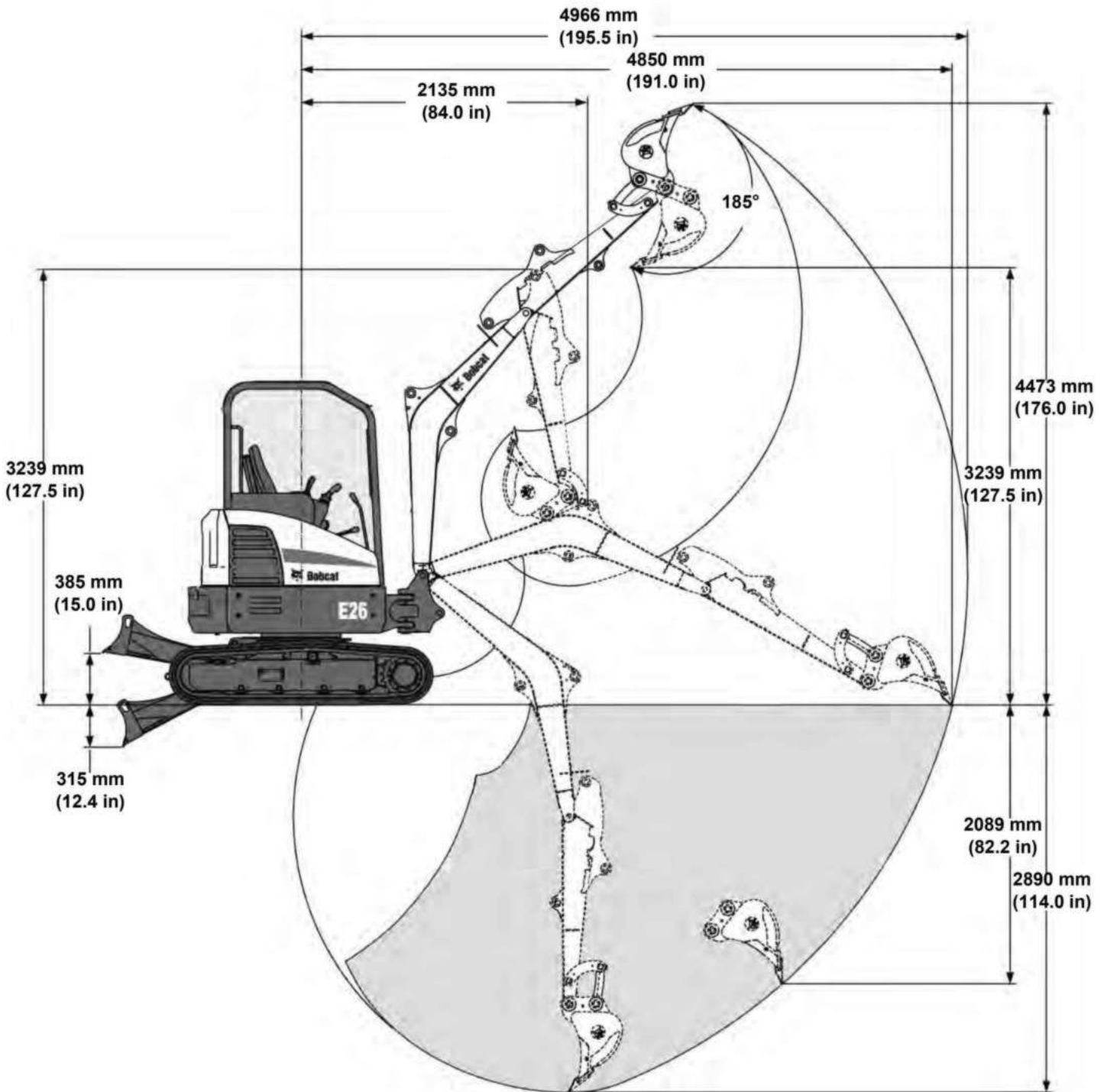

Dealer Copy -- Not for Resale

EM7547

(E26) EXCAVATOR SPECIFICATIONS (CONT'D)

Performance

Operating weight (canopy w/ rubber tracks, counterweight and standard bucket)	2570 kg (5666 lb)
If equipped with the following, add:	Cab w/ Heater, add 130 kg (287 lb); Cab w/ HVAC, add 149 kg (328 lb); Long Arm, add 10 kg (22 lb) Additional Counterweight, add 183 kg (403 lb)
Travel Speed (Low / High)	2,4 km/h / 4,5 km/h (1.5 mph / 2.8 mph)
Digging Force (per ISO 6015)	
With Standard Arm	Arm - 15800 N (3552 lb) Bucket - 22200 N (4991 lb)
With Long Arm	Arm - 13200 N (2967 lb) Bucket - 22200 N (4991 lb)

Controls

Steering	Two hand levers (optional foot pedals)
Hydraulics	Two hand operated levers (joysticks) control boom, bucket, arm and upperstructure slew
Blade	Hand lever
Two Speed	Switch on blade lever
Boom Swing	Electric switch in left joystick
Auxiliary Hydraulics	Electric switch in right joystick
Auxiliary Pressure Release	Electric switch in right joystick
Engine	Engine speed control dial with auto idle feature, key type start switch
Starting Aid	Glow Plugs - activated by key switch
Brakes Travel Service and Parking Slew Service Holding	Hydraulic lock in motor circuit Hydraulic lock on motor Spring applied - hydraulic release

Dealer Copy -- Not for Resale

(E26) EXCAVATOR SPECIFICATIONS (CONT'D)**Engine (E26 S/N B33211001 & Above)**

Make / Model	Kubota V1505-E4B-BCZ-2 Tier 4
Fuel / Cooling	Diesel NO.2-D / Liquid
Horsepower (SAE Net) @ 2400 rpm	18,5 kW (24.8 hp)
Torque @ 2100 rpm (SAE)	86,4 N•m (63.7 ft-lb)
Number Of Cylinders	4
Displacement	1,498 L (91.41 in ³)
Bore / Stroke	78 x 78,4 mm (2.99 x 2.90 in)
Lubrication	Forced Lubrication / Cartridge type
Crankcase Ventilation	Closed breathing
Air Cleaner	Dual dry replacement paper elements
Ignition	Diesel-Compression
Low Idle Speed	1100 ± 50 rpm
High Idle Speed	2500 max rpm
Engine Coolant	Propylene Glycol / water mixture (53% PG / 47% water)

Engine (E26 S/N AJRY11001 & Above)

Make / Model	Kubota V1505-E3B-BCZ-2 Interim Tier 4
Fuel / Cooling	Diesel NO.2-D / Liquid
Horsepower (SAE Net) @ 2400 rpm	20,1 kW (27 hp)
Torque @ 2100 rpm (SAE)	93,9 N•m (69.3 ft-lb)
Number Of Cylinders	4
Displacement	1,498 L (91.41 in ³)
Bore / Stroke	78 x 78,4 mm (2.99 x 2.90 in)
Lubrication	Forced Lubrication / Cartridge type
Crankcase Ventilation	Closed breathing
Air Cleaner	Dual dry replacement paper elements
Ignition	Diesel-Compression
Low Idle Speed	1000 ± 50 rpm
High Idle Speed	2500 max rpm
Engine Coolant	Propylene Glycol / water mixture (53% PG / 47% water)

Dealer Copy -- Not for Resale

(E26) EXCAVATOR SPECIFICATIONS (CONT'D)**Hydraulic System**

Pump Type	Engine driven, dual outlet, variable displacement, load sensing, torque limited, piston pump with gear pumps
Pump Capacity Piston Pump Gear Pump - 1 Gear Pump - 2	2 x 28,8 L/minute (2 x 7.6 U.S. gpm) 18,4 L/min (4.9 U.S. gpm) 6,2 L/min (1.6 U.S. gpm)
Auxiliary Flow	47,2 L/min (12.47 U.S. gpm)
Hydraulic Filter	Full flow replaceable, 3 micron synthetic media element
Control Valve	10 spool, parallel series type, open center.
Fluid Type	Bobcat Fluid, Hydraulic / Hydrostatic 6903117 - (2.5 U.S. gal) 6903118 - (5 U.S. gal) 6903119 - (55 U.S. gal)
System Relief Pressure Slew relief pressure Blade, Boom Swing Boom, Arm, Bucket, Travel Joystick Control Pressure	19098 kPa (191 bar) (2770 psi) 20595 kPa (206 bar) (2987 psi) 23994 kPa (240 bar) (3480 psi) 3199 kPa (32 bar) (464 psi)
Auxiliary Relief	17995 kPa (180 bar) (2610 psi)
Arm Port Relief Base And Rod End	28992 kPa (290 bar) (4205 psi)
Boom Port Relief Base And Rod End	28992 kPa (290 bar) (4205 psi)
Bucket Port Relief Base And Rod End	25993 kPa (260 bar) (3770 psi)
Blade Port Relief Base End	26993 kPa (270 bar) (3915 psi)
Main Hydraulic Filter Bypass	345 kPa (3,4 bar) (50 psi)
Case Drain	124 - 159 kPa (1,2 - 1,6 bar) (18 - 23 psi)

Dealer Copy -- Not for Resale

(E26) EXCAVATOR SPECIFICATIONS (CONT'D)

Hydraulic Cylinders

Cylinder	Bore	Rod	Stroke
Boom (cushion up)	69,9 mm (2.75 in)	41,3 mm (1.63 in)	546,1 mm (21.5 in)
Arm (cushion retract / extend)	69,9 mm (2.75 in)	41,3 mm (1.63 in)	492,3 mm (19.4 in)
Bucket	57,2 mm (2.25 in)	31,8 mm (1.25 in)	445,0 mm (17.52 in)
Boom Swing	69,9 mm (2.75 in)	38,1 mm (1.50 in)	385,3 mm (15.17 in)
Blade	82.6 mm (3.25 in)	44,5 mm (1.75 in)	145,0 mm (5.71 in)

Hydraulic Cycle Times

Bucket Curl	2,45 seconds
Bucket Dump	1,66 seconds
Arm Retract	2,55 seconds
Arm Extend	1,77 seconds
Boom Raise	3,6 seconds
Boom Lower	4,33 seconds
Boom Swing Left (60°)	3,38 seconds
Boom Swing Right (60°)	4,81 seconds
Blade Raise	1,79 seconds
Blade Lower	2,54 seconds

Electrical

Starting Aid	Glow Plugs
Alternator	12 volt, 90 Amp open frame w/ internal regulator
Battery	12 volt - 530 CCA @ -18°C (0°F)
Starter	12 volt; gear reduction 2,0 kw (2.7 hp)
Instrumentation	Fuel gauge, audible alarm, visual warning for engine functions and hourmeter
Lights	37.5 watt (2)

Drive System

Final Drive	Each track is driven by hydrostatic axial piston motor
Drive Reduction	41,9:1 two stage planetary
Gradeability	30*
Brakes	Hydraulic lock on motor

Dealer Copy -- Not for Resale

(E26) EXCAVATOR SPECIFICATIONS (CONT'D)**Slew System**

Slew Drive	Axial piston connected to a planetary drive
Slew Circle	Single row shear type ball bearings with internal gear
Gear Reduction	21.5:1
Brake	Spring applied, pressure released
Slew Speed	8,9 rpm

Undercarriage

Crawler Track Design	Sealed track rollers with boxed section track roller frame, grease type track adjuster with shock absorbing recoil spring
Width of crawler	1520 mm (59.8 in)

Capacities

Fuel Tank	34,6 L (9.14 U.S. gal)
Hydraulic Reservoir Only (Center of Sight Glass)	Tank Cap. 14,7 L (3.88 U.S. gal)
Hydraulic System (with Reservoir)	25,0 L (6.60 U.S. gal)
Cooling System	6,2L (1.64 U.S. gal)
Engine Oil and Filter	6,0 L (6.34 qt)
Final Drive (each)	0,6 L (0.63 qt)

Tracks

Type	Rubber
Width	300 mm (11.8 in)
Number Of Shoes	Single Assembly
Number of Track Rollers (per side)	4

Ground Pressure

Type	Rubber
Standard Arm	25,6 kPa (0,256 bar) (3.71 psi)
With long arm	25,7 kPa (0,257 bar) (3.73 psi)
With CTW	27,3 kPa (0,273 bar) (3.96 psi)
With CTW and long arm	27,4 kPa (0,274 bar) (3.97 psi)

Dealer Copy -- Not for Resale



Bobcat®

Dealer Copy -- Not for Resale

WARRANTY

WARRANTY179

Dealer Copy -- Not for Resale



Bobcat®

Dealer Copy -- Not for Resale

WARRANTY

Bobcat Excavators

Bobcat Company warrants to its authorized dealers and authorized dealers of Bobcat Equipment Ltd., who in turn warrant to the owner, that each new Bobcat Excavator will be free from proven defects in material and workmanship with respect to (i) all components of the product except as otherwise specified herein for twelve (12) months, (ii) tracks for twelve (12) months on a prorated basis based on the remaining depth of the track at the time any defect is discovered, and (iii) Bobcat brand batteries, for an additional twelve (12) months after the initial twelve month warranty period, provided that Bobcat Company shall only reimburse a fixed portion of the cost of replacing the battery during such additional twelve months. The foregoing time periods shall all commence after delivery by the authorized Bobcat dealer to the original buyer.

During the warranty period, the authorized Bobcat dealer shall repair or replace, at Bobcat Company's option, without charge for parts and labor, any part of the Bobcat product except as otherwise specified herein which fails because of defects in material or workmanship. The owner shall provide the authorized Bobcat dealer with prompt written notice of the defect and allow reasonable time for repair or replacement. Bobcat Company can, at its option, require failed parts to be returned to the factory. Travel time of mechanics and transportation of the Bobcat product to the authorized Bobcat dealer for warranty work are the responsibility of the owner. The remedies provided in this warranty are exclusive.

This warranty does not apply to diesel engine fuel injection pumps and injectors. The owner shall rely solely on the warranty, if any, of the respective manufacturers thereof. This warranty does not cover replacement of scheduled service items such as oil, filters, tune-up parts, and other high-wear items. This warranty does not cover damages resulting from abuse, accidents, alterations, use of the Bobcat product with any accessory or attachment not approved by Bobcat Company, air flow obstructions, or failure to maintain or use the Bobcat product according to the instructions applicable to it.

THIS WARRANTY IS EXCLUSIVE AND IN LIEU OF ALL OTHER WARRANTIES AND CONDITIONS, EXCEPT THE WARRANTY OF TITLE. BOBCAT COMPANY DISCLAIMS ALL OTHER WARRANTIES AND CONDITIONS, EXPRESS OR IMPLIED, INCLUDING ANY IMPLIED WARRANTIES OR CONDITIONS OF MERCHANTABILITY OR FITNESS FOR A PARTICULAR PURPOSE. IN NO EVENT SHALL BOBCAT COMPANY OR THE AUTHORIZED BOBCAT DEALER BE LIABLE FOR ANY SPECIAL, INCIDENTAL, INDIRECT OR CONSEQUENTIAL DAMAGES, WHATSOEVER, INCLUDING, BUT NOT LIMITED TO, LOSS OR INTERRUPTION OF BUSINESS, LOST PROFITS, OR LOSS OF MACHINE USE, WHETHER BASED ON CONTRACT, WARRANTY, TORT, NEGLIGENCE, STRICT LIABILITY, STATUTE OR OTHERWISE, EVEN IF BOBCAT COMPANY OR THE AUTHORIZED BOBCAT DEALER HAS BEEN ADVISED OF THE POSSIBILITY OF SUCH DAMAGES. THE TOTAL LIABILITY OF BOBCAT COMPANY AND THE AUTHORIZED BOBCAT DEALERS WITH RESPECT TO THE PRODUCT AND SERVICES FURNISHED HEREUNDER SHALL NOT EXCEED THE PURCHASE PRICE OF THE PRODUCT UPON WHICH SUCH LIABILITY IS BASED.



6570375 (2-09)

Printed in U.S.A.

Dealer Copy -- Not for Resale

In this emissions limited warranty, the term "Manufacturer" means Kubota Corporation as the holder of the U.S. Environmental Protection Agency (U.S. EPA) Certificate of Conformity and California Executive Order for the vehicle. The emission control limited warranty is in addition to the standard limited warranty for your vehicle.

Your Bobcat dealer is authorized to perform all warranty and service repairs on your diesel engine. To locate a Bobcat dealer, visit www.bobcat.com or call 1-800-743-4340.

KUBOTA Corporation

FEDERAL & CALIFORNIA EMISSION CONTROL SYSTEMS LIMITED WARRANTY for NON-ROAD ENGINES (CI)

The U.S. Environmental Protection Agency (EPA), the California Air Resources Board (CARB), and KUBOTA Corporation are pleased to explain the Federal and California Emission Control System Warranty on your non-road engine. In California, new heavy duty off-road engines must be designed, built and equipped to meet California's stringent anti-smog standards adopted by the Air Resources Board pursuant to its authority in Chapter 1 and 2, Part 5, Division 26 of the California Health and Safety Code. In other states of the U.S.A., new non-road engines subject to the provisions of 40 CFR 1039 subpart A must be designed, built and equipped, at the time of sale, to meet the U.S. EPA regulations for nonroad engines.

KUBOTA must warrant the emission control system on your Compression Ignition engine for the period of time listed below provided there has been no abuse, vandalism, neglect, improper maintenance or unapproved modifications to your engine. This emission warranty is applicable in all states of the U.S.A., its provinces and territories regardless of whether an individual state, province, or territory has enacted warranty provisions that differ from the Federal warranty provisions. This emission warranty is also applicable in all provinces and territories of CANADA.

Your emission control system may include parts such as the fuel injection system and the air induction system. Also included may be hoses, belts, connectors and other emission-related assemblies.

Where a warrantable condition exists, KUBOTA will repair your engine at no cost to you, including diagnosis (if the diagnostic work is performed at an authorized dealer), parts and labor.

EMISSION DESIGN AND DEFECT WARRANTY COVERAGE

The emissions warranty period for the engine begins on the original date of sale to the initial purchaser and continues for each subsequent purchaser for the period mentioned below.

The emissions warranty period for all engines rated under 19kW (25Hp) is 2000 hours of operation or two (2) years of use, whichever first occurs.

The emissions warranty period for constant speed engines rated under 37kW (50Hp) with rated speeds greater than or equal to 3000 rpm is 2000 hours of operation or two (2) years of use, whichever first occurs.

The emissions warranty period for all other engines not already listed is 3000 hours of operation or five (5) years of use, whichever first occurs.

If any emission related part on your engine is defective, the part will be repaired or replaced by KUBOTA free of charge.

OWNER'S WARRANTY RESPONSIBILITIES

- (a) As the engine owner, you are responsible for the performance of the required maintenance listed in your KUBOTA operator's manual. KUBOTA recommends that you retain all receipts covering maintenance on your engine, but KUBOTA cannot deny a warranty claim solely for the lack of receipts or for your failure to ensure the performance of all scheduled maintenance.
- (b) As the engine owner, you should be aware, however, that KUBOTA may deny your warranty coverage if your engine or a part has failed due to abuse, vandalism, neglect, improper maintenance or unapproved modifications.
- (c) Your engine is designed to operate on Ultra Low Sulfur Diesel Fuel only. Use of any other fuel may result in your engine no longer operating in compliance with Federal or California's emissions requirements.
- (d) You are responsible for presenting your engine to the nearest dealer or service station authorized by KUBOTA when a problem exists. The warranty repairs should be completed in a reasonable amount of time, not to exceed 30 days.
- (e) If you have any questions regarding your warranty rights and responsibilities or the location of the nearest authorized dealer or distributor, you should contact: KUBOTA ENGINE AMERICA CORPORATION, Service department at 1-800-532-9808, EEWRI@kubotaengine.com or KUBOTA TRACTOR CORPORATION, National Service Department at 1-800-558-2682, KubotaEmissionsWarranty@kubota.com or KUBOTA CANADA LTD at (905) 294-7477.

COVERAGE

KUBOTA warrants to the initial purchaser and each subsequent purchaser that your engine will be designed, built and equipped, at the time of sale, to meet all applicable regulations. KUBOTA also warrants to the initial purchaser and each subsequent purchaser that your engine shall be free from defects in materials and workmanship which cause the engine to fail to conform to applicable regulations for the period mentioned above from the original date of sale.

KUBOTA shall remedy warranty defects at any authorized KUBOTA engine dealer or warranty station. Any authorized work done at an authorized dealer or warranty station shall be free of charge to the owner if such work determines that a warranted part is defective. Any KUBOTA approved or equivalent replacement part (including any KUBOTA approved aftermarket part) may be used for any warranty maintenance or repairs on emission related parts, and must be provided free of charge to the owner if the part is still under warranty.

KUBOTA is liable for damages to other engine components caused by the failure of a warranted part still under warranty. The use of replacement parts not equivalent to the original parts may impair the effectiveness of your engine emission control system. If such a replacement part is used in the repair or maintenance of your engine, and KUBOTA determines it is defective or causes a failure of a warranted part, your claim for repair of your engine may be denied.

Listed below are the parts covered by the Federal and California Emission Control Systems Warranty. Some parts listed below may require scheduled maintenance and are warranted up to the first scheduled replacement point for that part. The warranted parts are (if applicable):

- | | | |
|---|---|--|
| <ol style="list-style-type: none"> 1) Air-Induction System <ol style="list-style-type: none"> a) Intake Manifold b) Turbocharger System c) Charge Air Cooling System (Intercooler) 2) Catalyst or Thermal Reactor System <ol style="list-style-type: none"> a) Catalytic converter b) Exhaust manifold 3) Fuel Injection System <ol style="list-style-type: none"> a) Fuel Supply Pump b) Injector c) Injection Pipe d) Common Rail e) Smoke Puff Limiter f) Speed Timer g) Cold Advance Timer h) Injection Pump | <ol style="list-style-type: none"> 4) Electronic Control System <ol style="list-style-type: none"> a) ECU b) Engine Speed / Timing Sensor c) Accelerator Position Sensor d) Coolant Temperature Sensor e) Atmospheric Pressure Sensor f) Intake Pressure Sensor g) Intake Manifold Temperature Sensor h) Intake Air Flow Sensor i) Common Rail Pressure Sensor 5) Exhaust Gas Recirculation System <ol style="list-style-type: none"> a) EGR Valve b) EGR Cooler c) EGR Valve Opening Rate Sensor | <ol style="list-style-type: none"> 6) Particulate Controls <ol style="list-style-type: none"> a) Any device used to capture particulate emissions. b) Any device used in the regeneration of the particulate control device. c) Control Device Enclosures and Manifolding d) Diesel Particulate Filter Temperature Sensor e) Differential Pressure Sensor 7) Miscellaneous Items <ol style="list-style-type: none"> a) Closed Breather System b) Hoses*, Clamps*, Fittings, Tubing* c) Gaskets, Seals d) Kubota supplied engine Wiring Harnesses e) Kubota supplied engine Elec. Connectors f) Air Cleaner Element*, Fuel Filter Element* g) Emission Control Information Labels |
|---|---|--|

*Warranty period is equivalent to manufacturer's recommended first replacement interval as stated in the applicable model's operator's manual and/or service (workshop) manual.

MAINTENANCE REQUIREMENTS

The owner is responsible for the performance of the required maintenance as defined by KUBOTA in the operator's manual.

LIMITATIONS

This Emission Control System Warranty shall not cover any of the following:

- (a) Repair or replacement required because of misuse or neglect, improper maintenance, repairs improperly performed or replacements not conforming to KUBOTA specifications that adversely affect performance and/or durability, and alteration or modifications not recommended or approved in writing by KUBOTA.
- (b) Replacement of parts and other services and adjustments necessary for required maintenance at and after the first scheduled replacement point.



ALPHABETICAL INDEX

(E26) EXCAVATOR SPECIFICATIONS	167	PIVOT PINS	126
AIR CLEANER SERVICE	95	PRE-STARTING PROCEDURE	52
AIR CONDITIONING COMPRESSOR BELT	121	PUBLICATIONS AND TRAINING RESOURCES	19
ALTERNATOR AND FAN BELT	120	REGULAR MAINTENANCE ITEMS	7
ATTACHMENTS	60	RIGHT SIDE COVER	93
BLADE CONTROL LEVER	49	SAFETY INSTRUCTIONS	15
BOBCAT COMPANY IS ISO 9001 CERTIFIED	7	SEAT BELT	89
BOOM SWING	50	SERIAL NUMBER LOCATIONS	8
BUCKET	122	SERVICE SCHEDULE	87
CAB FILTERS	94	SPARK ARRESTOR MUFFLER	115
CONTROL CONSOLE LOCKOUTS	88	SPARK ARRESTOR MUFFLER	116
DAILY INSPECTION	51	STARTING THE ENGINE	55
DELIVERY REPORT	8	STOPPING THE ENGINE AND LEAVING THE EXCAVATOR	59
DIAGNOSTIC SERVICE CODES	131	TAILGATE	92
DISPLAY CONTROLLER PANEL SETUP	133	TOWING THE EXCAVATOR	78
ELECTRICAL SYSTEM	106	TRACK ROLLER AND IDLER LUBRICATION	122
EMERGENCY EXIT	39	TRACK TENSION	117
ENGINE COOLING SYSTEM	103	TRANSPORTING THE EXCAVATOR ON A TRAILER	80
ENGINE LUBRICATION SYSTEM	101	TRAVEL CONTROLS	41
ENGINE SPEED CONTROL	49	TRAVEL MOTOR	119
EXCAVATOR IDENTIFICATION	9	WARRANTY	179
EXCAVATOR STORAGE AND RETURN TO SERVICE	127	X-CHANGE™	121
FEATURES, ACCESSORIES AND ATTACHMENTS	10		
FIRE PREVENTION	17		
FUEL SYSTEM	97		
HYDRAULIC CONTROLS	43		
HYDRAULIC SYSTEM	111		
INSTRUMENTS AND CONSOLES	27		
LIFTING THE EXCAVATOR	79		
LUBRICATION OF THE HYDRAULIC EXCAVATOR	123		
MACHINE SIGN TRANSLATIONS	139		
MACHINE SIGNS (DECALS)	20		
MAINTENANCE CLOCK	135		
MAINTENANCE SAFETY	85		
MOTION ALARM SYSTEM	40		
MOTION ALARM SYSTEM	90		
OPERATING PROCEDURE	67		
OPERATOR CAB (ROPS / TOPS)	32		
OPERATOR CANOPY (ROPS / TOPS)	32		
OPERATOR SAFETY WARNING	1		

Dealer Copy -- Not for Resale



Bobcat®

Dealer Copy -- Not for Resale